

Teileliste und Naehinrichtungen
Parts List and Sewing Equipment

867 Standard

DÜRKOPP ADLER AG

Postfach 17 03 51, D-33703 Bielefeld • Potsdamer Str. 190, D-33719 Bielefeld
Telefon +49 (0) 5 21/ 9 25-00 • Telefax +49 (0) 5 21/ 9 25 24 35 • www.duerkopp-adler.com

Ausgabe / Edition: 10/2012	Aenderungindex Rev. index: 01.0	Printed in Czech Republic	Teile-Nr./Part.-No.: 0791 867821
--------------------------------------	---	---------------------------	--

Alle Rechte vorbehalten.
Eigentum der Dürkopp Adler AG und urheberrechtlich geschützt. Jede, auch auszugsweise
Wiederverwendung dieser Inhalte ist ohne vorheriges schriftliches Einverständnis der Dürkopp Adler AG
verboten.

All rights reserved.

Property of Dürkopp Adler AG and copyrighted. Reproduction or publication of the content in any manner,
even in extracts, without prior written permission of Dürkopp Adler AG, is prohibited.

Copyright © Dürkopp Adler AG - 2012

867 Standard

Inhaltsverzeichnis	Tafel / Table	Contents
Armwelle	1	Upper shaft
Armwelle-Sensitiv		Upper shaft-Sensitiv
Antrieb Arm- und Unterwelle, Rastkupplung	2	Upper and bottom shaft drive, Safety clutch
Fadenhebel	3	Thread lever
Fadenhebel-Sensitiv	4	Thread lever-Sensitiv
Antrieb Nadeltransport	5	Needle feed drive
Alternierender Obertransport, Alternierender Obertransport-Sensitiv, Fussfuehrung	6	Alternating foot top feed, Alternating foot top feed-Sensitiv, Foot guide
Antrieb Untertransport	7	Bottom feed drive
Transporteurhub	8	Bottom feed
Fusslueftung	9	Presser foot lift hand lever
Fusslueftung mech.	10	Presser foot lift knee lever
Fusslueftung pneu.	11	Presser foot lift pneumatic
Hubverstellung	12	Skipping foot lift pneumatic
Grosser Greifer mit Spule-Sensitiv	13	Large hook with bobbin-Sensitiv
Grosser Greifer mit Spule	14	Large hook with bobbin
Grosser Greifer	15	Large hook
Uebergrosser Greifer mit Spule	16	Oversized hook with bobbin
Uebergrosser Greifer mit Spule KFA	17	Oversized hook with bobbin short thread trimmer
Grosser Greifer mit Spule KFA	18	Large hook with bobbin short thread trimmer
Greiferlager rechts	19	Hook case right
Greiferlager links	20	Hook case left
Fadenabschneider	21	Thread trimmer
Kurz-Fadenabschneider	22	Short thread trimmer
Spuler	23	Winder
Spannungsplatte Einnadel mech.	24	Tension plate 1 needle mech.
Spannungsplatte Einnadel pneu.	25	Tension plate 1 needle pneu.
Spannungsplatte Einnadel pneu.	26	Tension plate 1 needle, pneu.
Spannungsplatte Einnadel pneu. -Sensitiv		Tension plate 1 needle, pneu. -Sensitiv
Spannungsplatte Einnadel pneu.-NSB	27	Tension plate 1 needle, pneu.-NSB
Spannungsplatte Zweinadel mech.	28	Tension plate 2 needles mech.
Spannungsplatte Zweinadel pneu.	29	Tension plate 2 needles pneu.
Spannungsplatte Zweinadel pneu.	30	Tension plate 2 needles pneu.
Spannungsplatte Zweinadel pneu. -Sensitiv		Tension plate 2 needles pneu. -Sensitiv
Stichverstellung 1 Stichlaenge, Stichverkuerzung	31	Stitch adjustment 1 stitch length, Stitch reduction
Stichverstellung 2 Stichlaengen, Stichverkuerzung	32	Stitch adjustment 2 stitch lengths, Stitch reduction
Verriegelung mech., pneu., Stichverkuerzung	33	Backtacking mech., pneu., Stitch reduction
Magnetventileinheit, Taster	34 - 37	Solenoid valve unit, Push-buttons
Zentralschmierung	38	Central lubrication

867 Standard

Inhaltsverzeichnis	Tafel / Table	Contents
Arm, Fadenfuehrung, Integr. Diodennaehleuchte	39	Arm, Thread guide, Sewing light LEDs
Armdeckel ECO	40	Arm cover ECO
Armdeckel CLASSIC	41	Arm cover CLASSIC
Armdeckel CLASSIC mit Blockierung	42	Arm cover CLASSIC with blocking
Grundplatte	43	Bed plate
Naehleuchte Halogen	44	Sewing lamp halogen
Teilesatz fuer DAC ECO	45	Part set for DAC ECO
Teilesatz fuer DAC Classic	46	Part set for DAC Classic
Teilesatz fuer EFKA DC1550/DA321G	47	Part set for EFKA DC1550/DA321G
Bedienfeld		Control panel
Teilesatz	48	Part set
Gestell	49	Stand
Wartungseinheit	50	Maintenance unit
Beipack	51, 52	Accessories
Restfadenwaechter	53	Thread monitor
Elektropneum. Nadelkuehlung von oben, unten	54	Electropneum. needle cooling upper, lower
Integr. Diodennaehleuchte	55	Sewing light LEDs
Netzteil		Power supply
Kantenanschlag		Edge guide
Kantenanschlag		Edge guide
Lineal auf Schieber		Edge guide
Rollenanschlag		Roller stop
Nahtmittenfuehrung schwenkbar		Swivelling seam centre guide
Nahtmittenfuehrung		Seam centre guide
Nahtmittenfuehrung von vorne pneum. schaltbar	56	Electropneum. seam centre guide
Eindiodennaehleuchte	57	Sewing lamp LED
Fuesschenlueftung pneu.	58	Sewing foot lift pneu.
Fuesschenlueftung mech.		Manual foot lift pedal
Bedienfeldwinkel		Angle for control panel
Visuelle Spulenueberwachung	59	Visual monitoring of bobbin
Reflexlichtschanke	60	Light barrier
Teilesatz NSB		Part set NSB
Werkzeug M-Type		Tool kits M-Type
Stichlaengeblockierung	61	Stitch length blocking
Drehzahlregler		Speed regulator
Teilesatz FK		Parts set FK
Index		Index
Stichplattenschieber		Slide
Befestigungsteile fuer Naehleinrichtung		Fastening parts for sewing equip.
Naehleinrichtungen		Sewing equipment
Bauschaltplan		Wiring diagram
Pneu. Geraeteplan		Pneumatic circuit plan

867 Standard

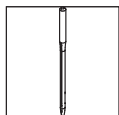

Einnadel-Maschine
single needle machine



Zweinadel-Maschine
two needle machine

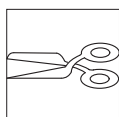

mit Fadenabschneider
with thread trimmer

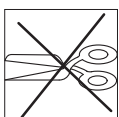

ohne Fadenabschneider
without thread trimmer

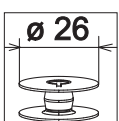

Ø 26
grosser Greifer
large hook

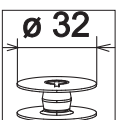

Ø 32
uebergrosser Greifer (XXL)
oversized hook (XXL)



Kurz-Fadenabschneider
short thread trimmer



ohne Kurz-Fadenabschneider
without short thread trimmer



kleben/stick

N nicht einzeln lieferbar/not available as separate part

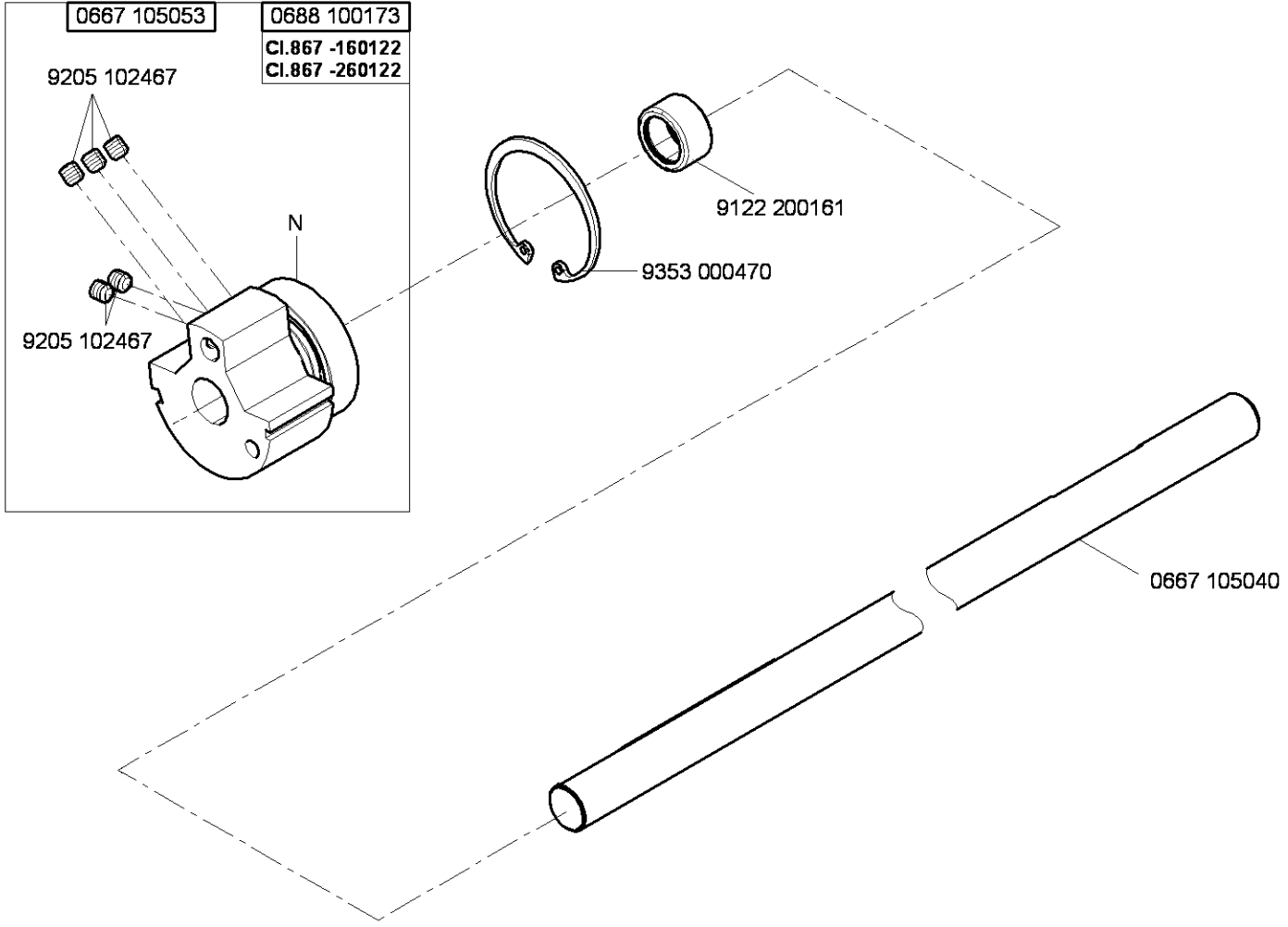

N - nicht als Einzelteil lieferbar
not available as separate part

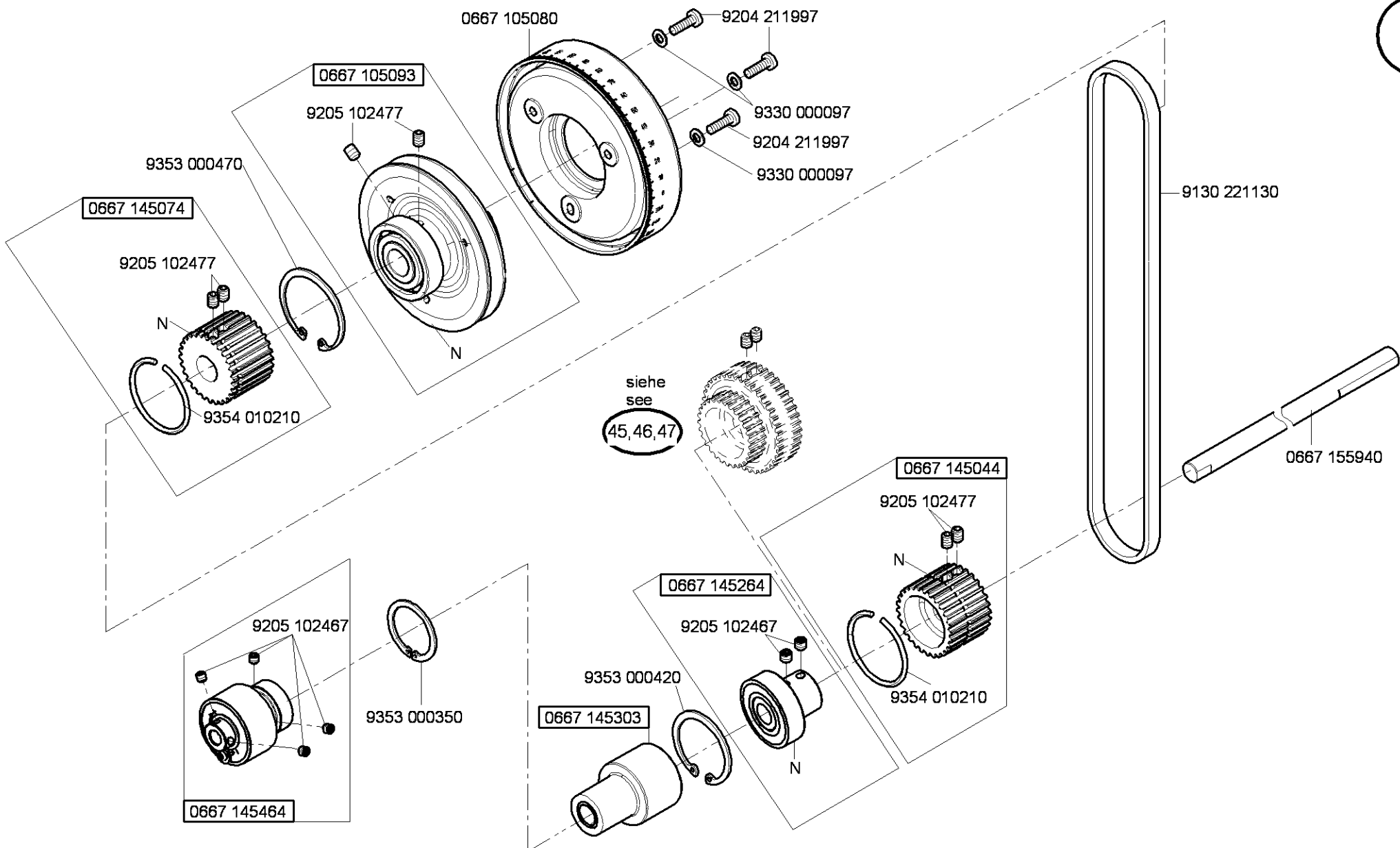

N - nicht als Einzelteil lieferbar
not available as separate part

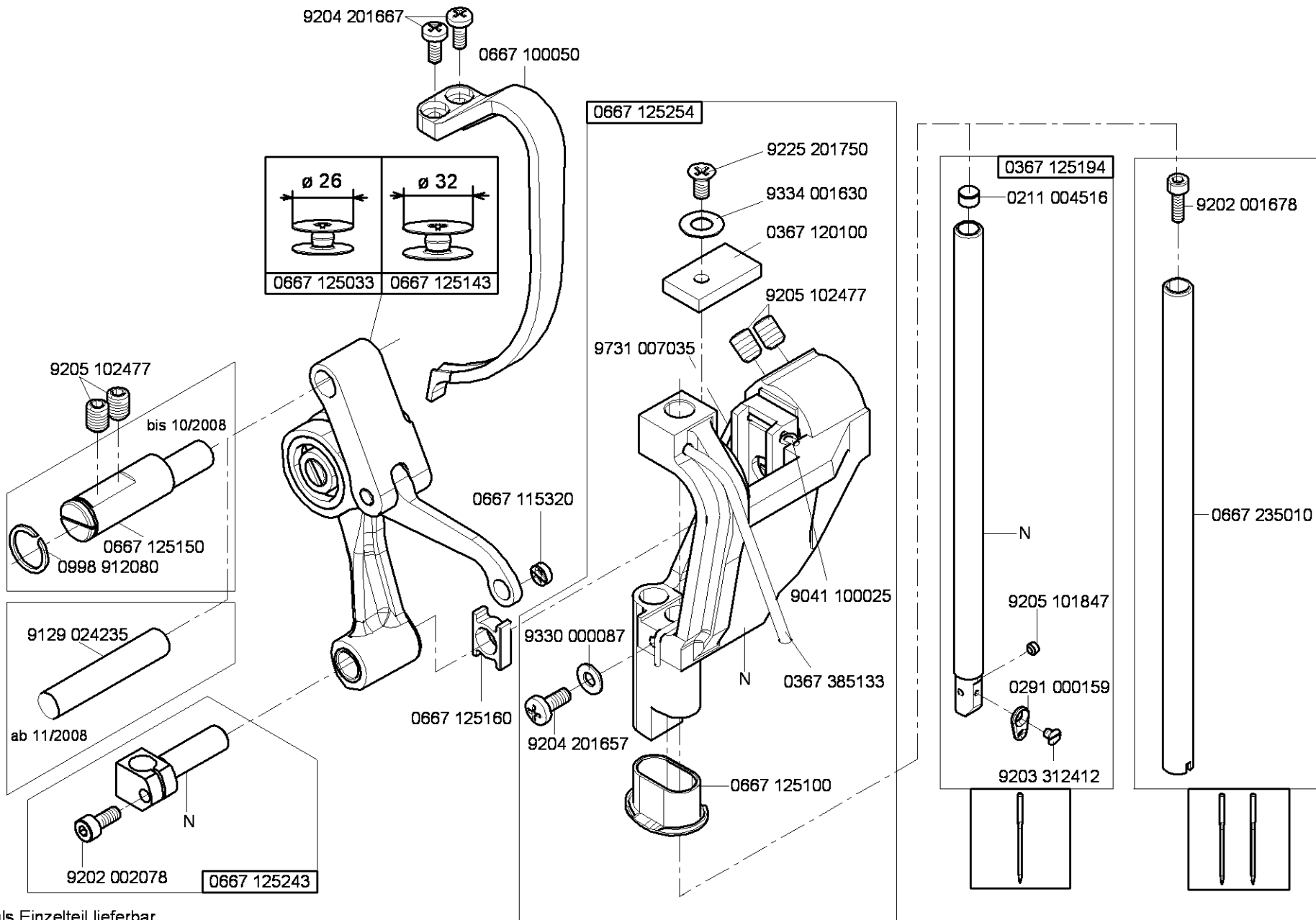

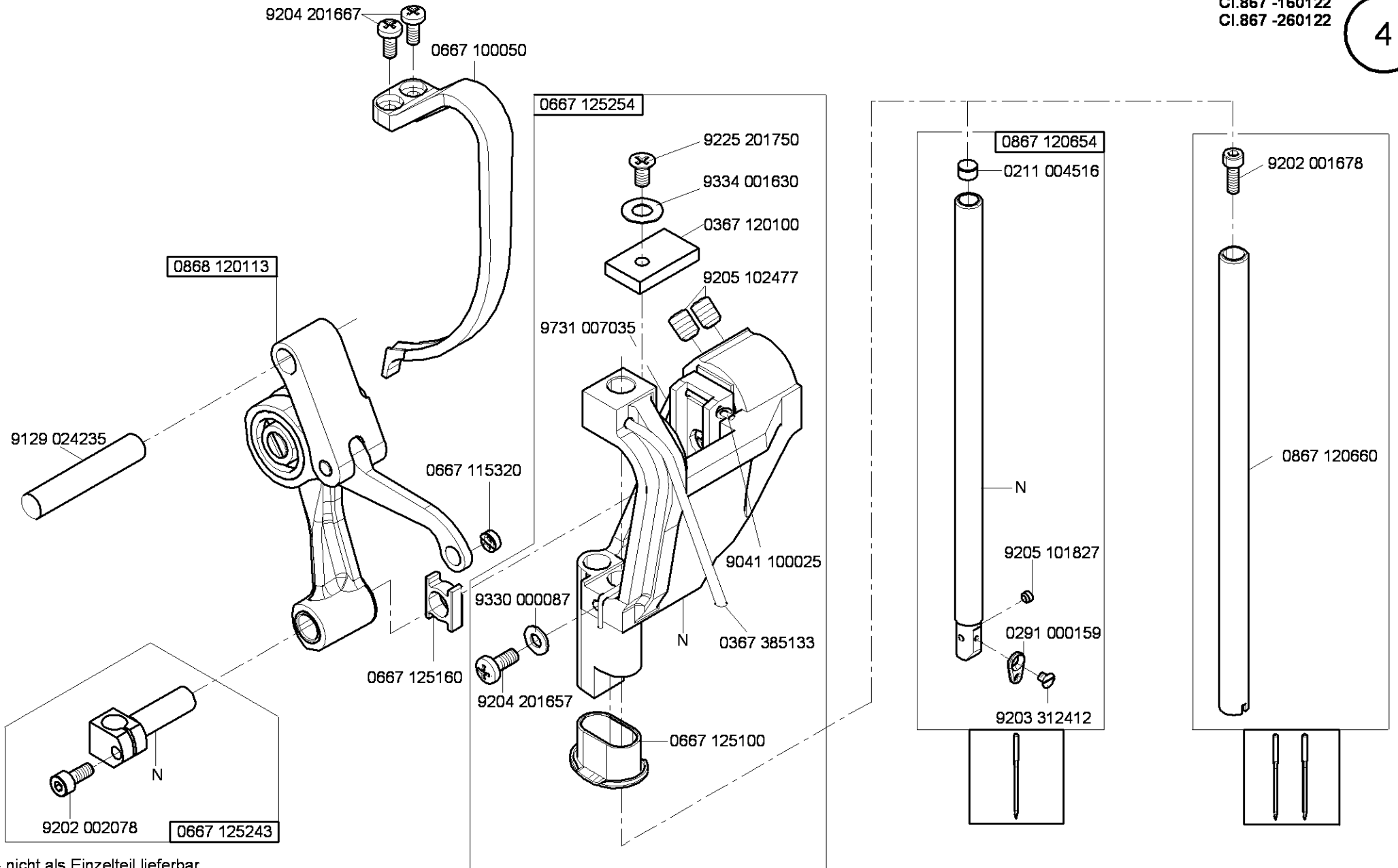

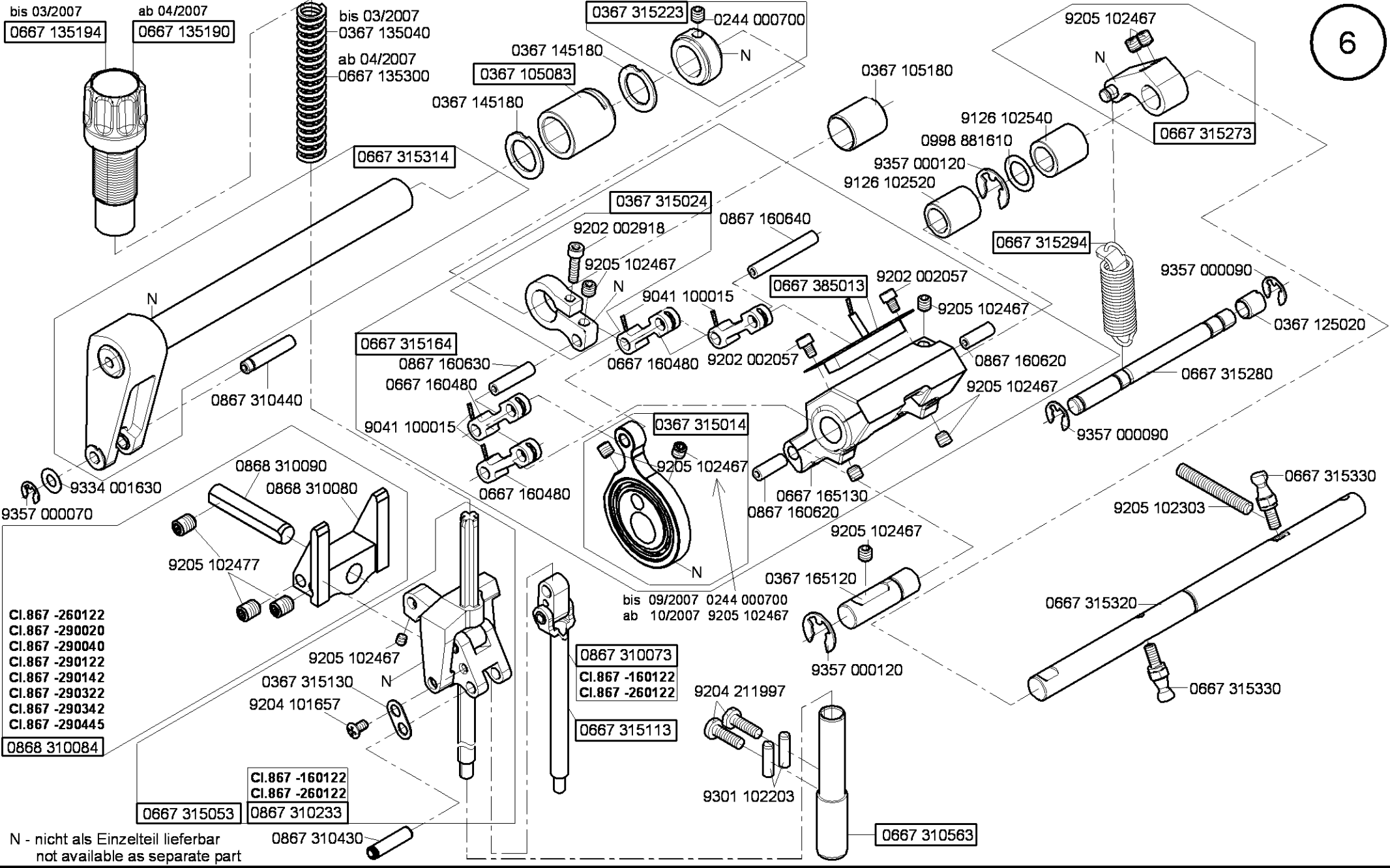

N - nicht als Einzelteil lieferbar
not available as separate part

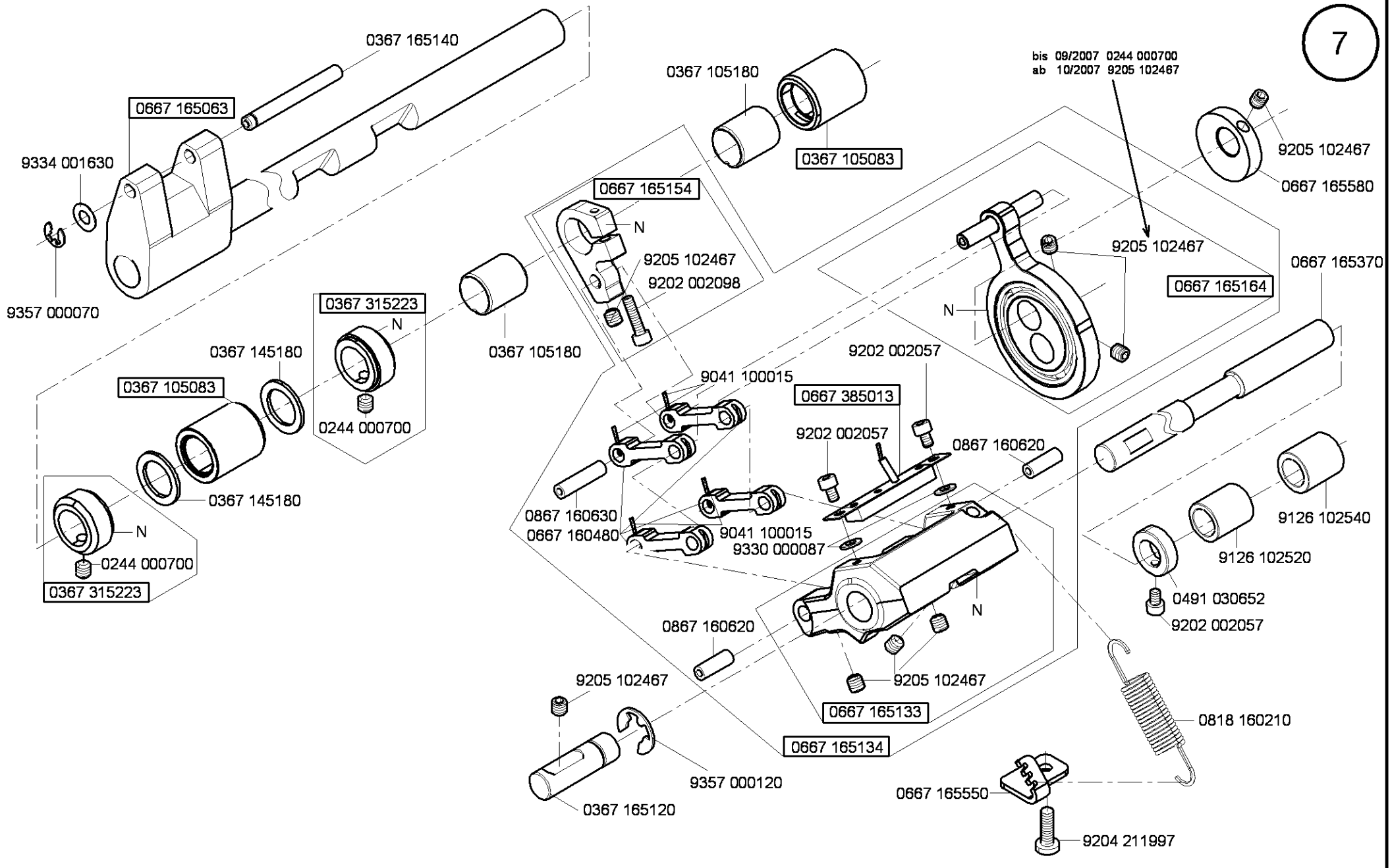

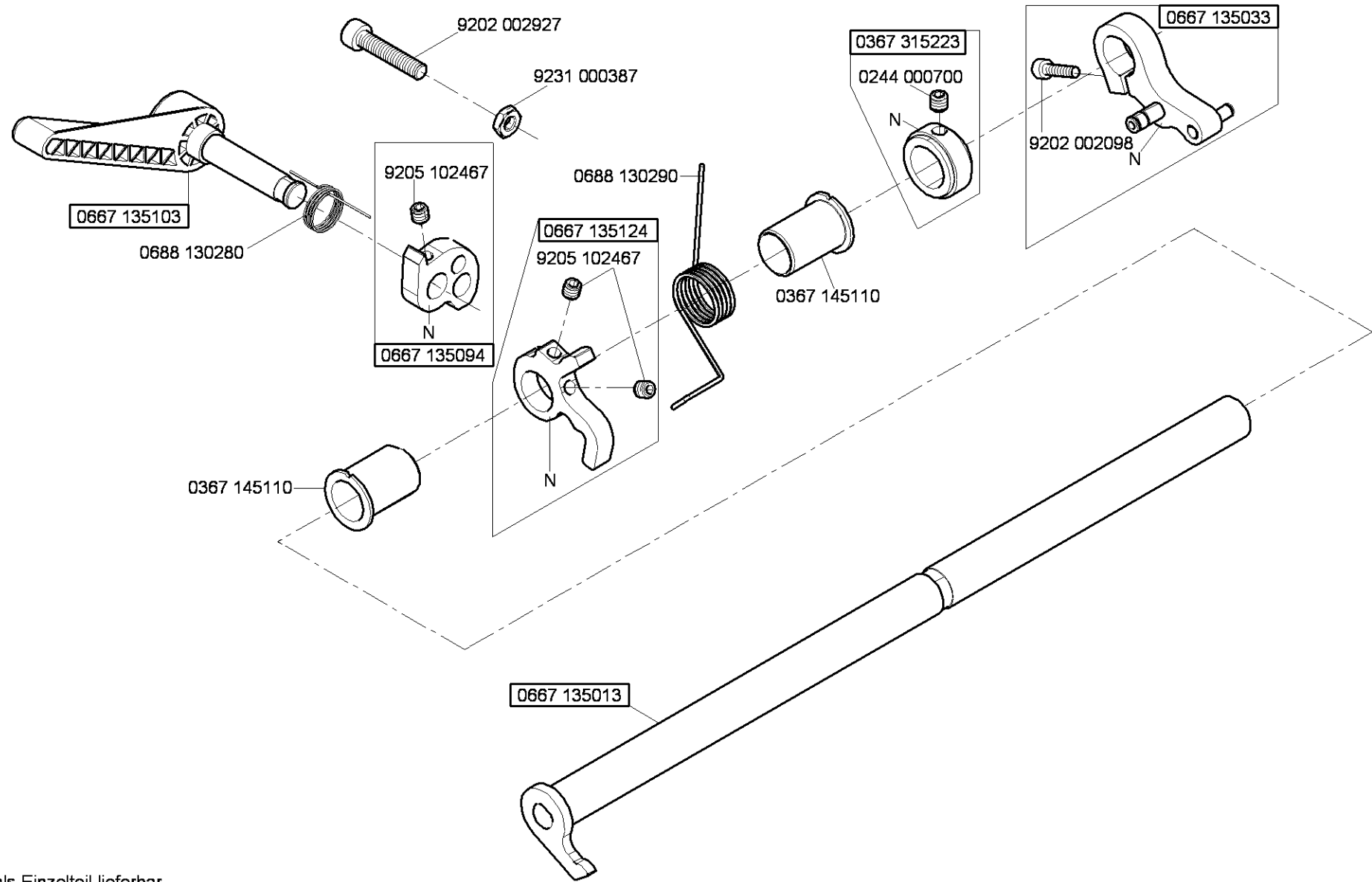

N - nicht als Einzelteil lieferbar
not available as separate part

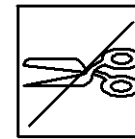

CI.867 -190020
 CI.867 -190040
 CI.867 -290020
 CI.867 -290040

10

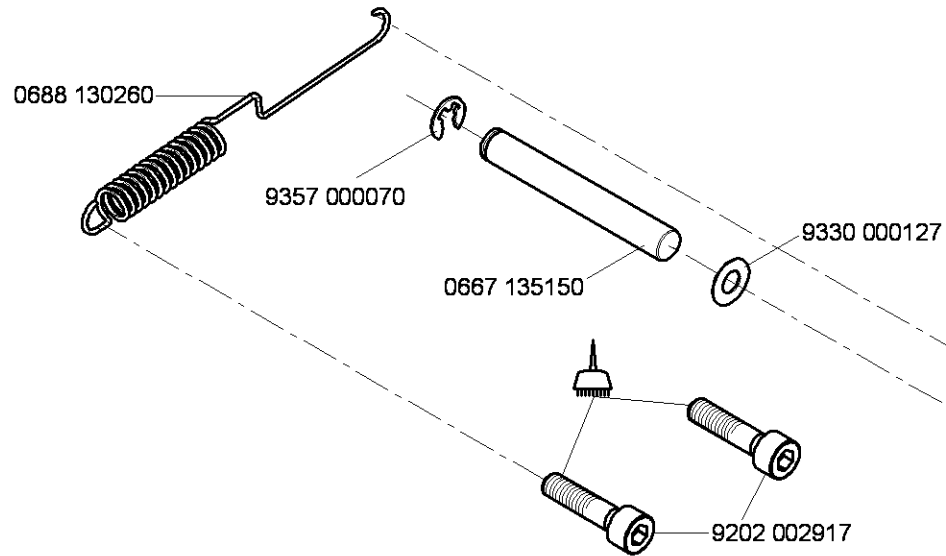

9357 000070

9357 000070

0667 135040

0667 135073

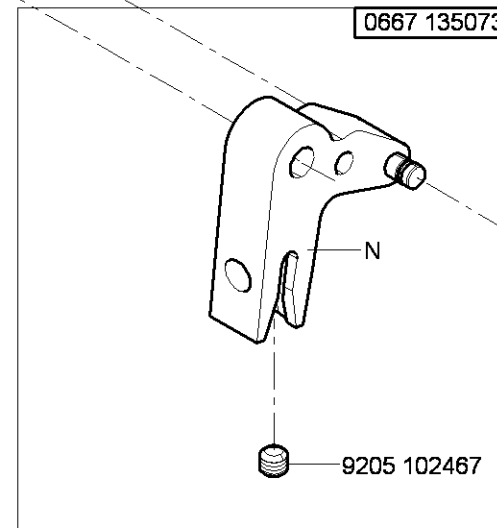

9334 001630

9357 000070

N - nicht als Einzelteil lieferbar
 not available as separate part  -kleben -stick

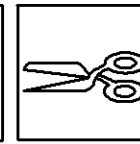
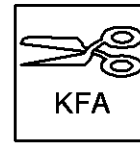

- CI.867 -160122
- CI.867 -190122
- CI.867 -190125
- CI.867 -190142
- CI.867 -190145
- CI.867 -190146
- CI.867 -190322
- CI.867 -190342
- CI.867 -190425
- CI.867 -190445
- CI.867 -260122
- CI.867 -290122
- CI.867 -290142
- CI.867 -290322
- CI.867 -290342
- CI.867 -290445

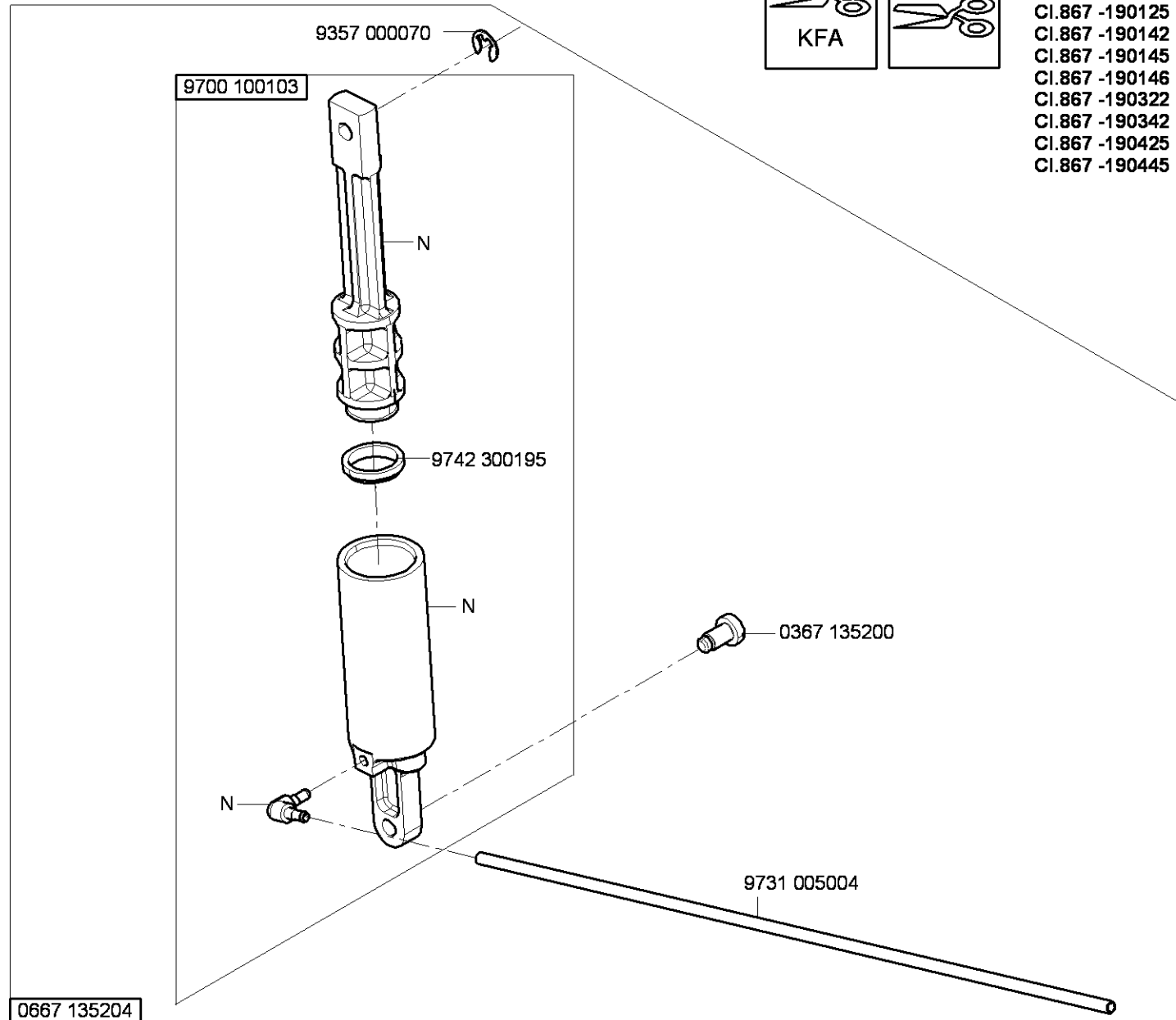

N - nicht als Einzelteil lieferbar
not available as separate part

0667 135204

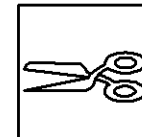
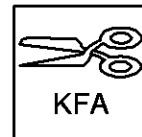

CI.867 -190322
 CI.867 -190342
 CI.867 -190425
 CI.867 -190445
 CI.867 -290322
 CI.867 -290342
 CI.867 -290445

9880 867104

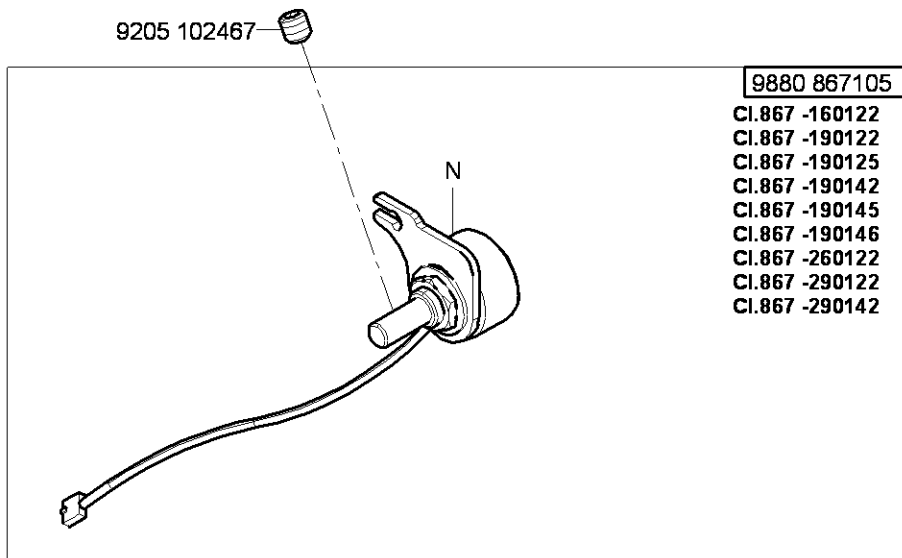
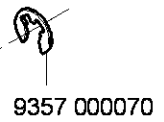
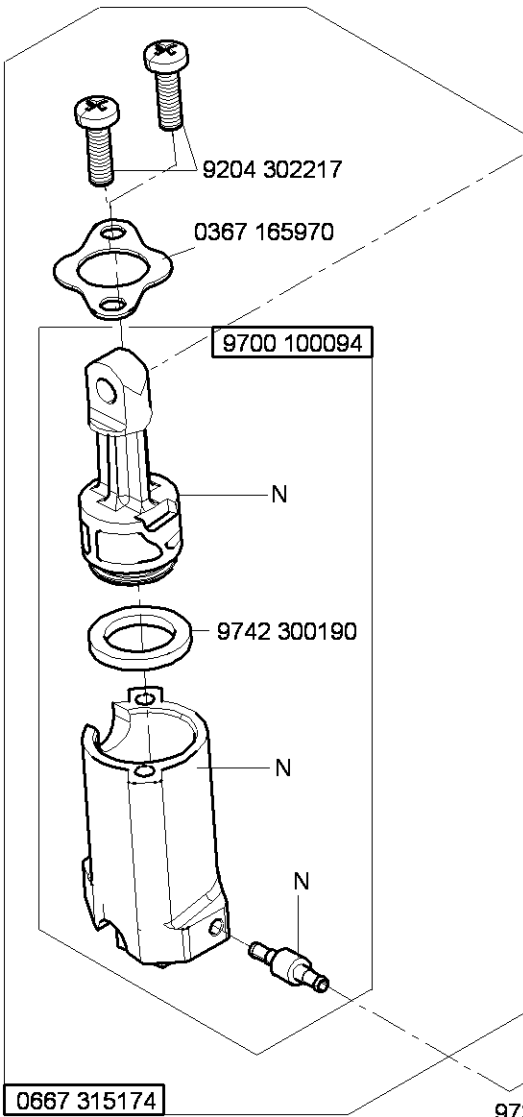
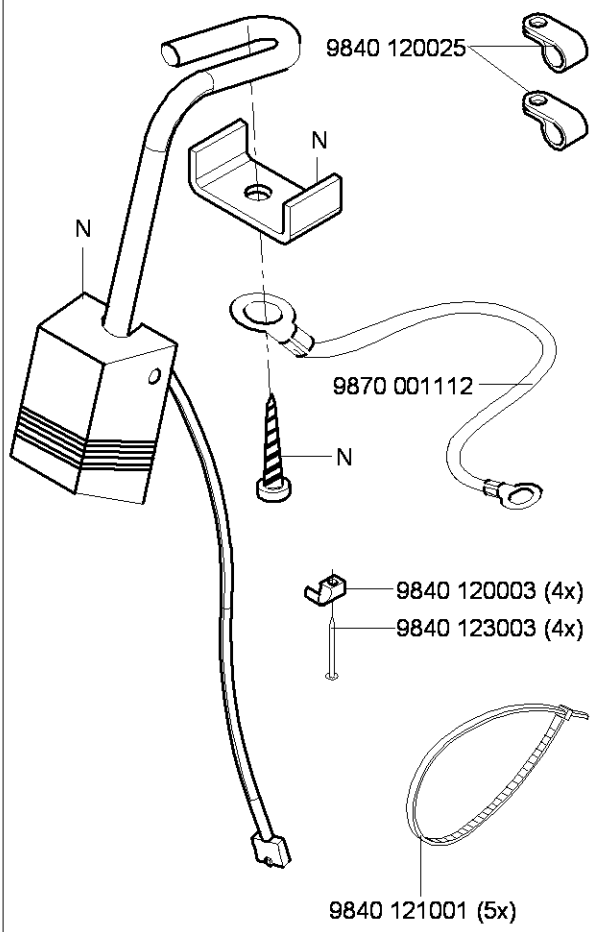

N - nicht als Einzelteil lieferbar
 not available as separate part

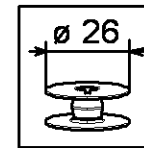

CI.867 -160122
CI.867 -260122

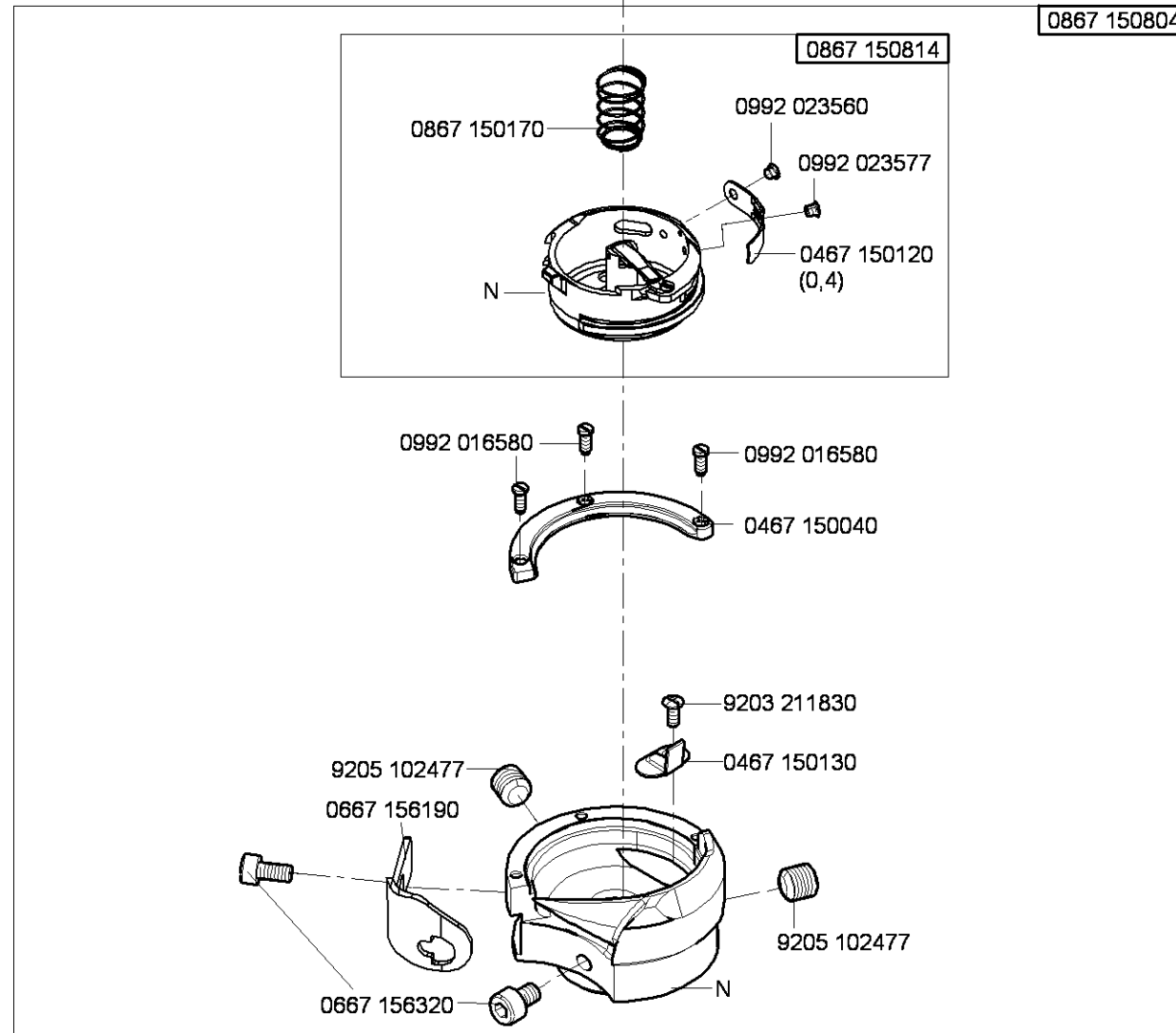

N - nicht als Einzelteil lieferbar
not available as separate part

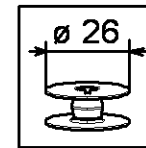

CI.867 -190020
 CI.867 -190122
 CI.867 -190322
 CI.867 -290020
 CI.867 -290122
 CI.867 -290322

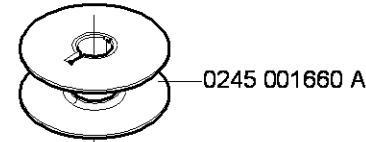

0667 155604

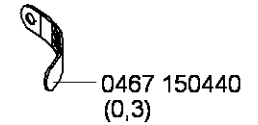
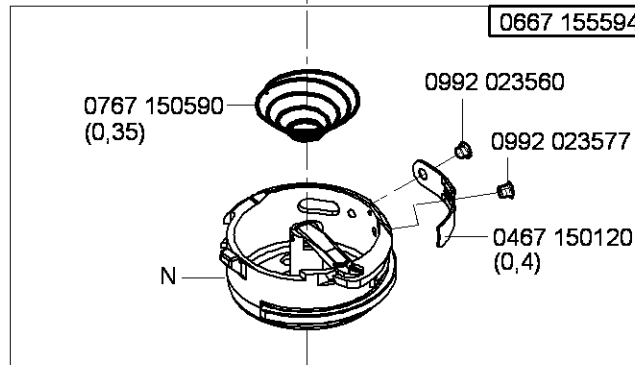

auf Wunsch
on request

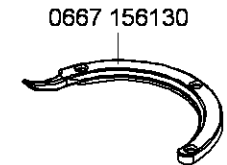
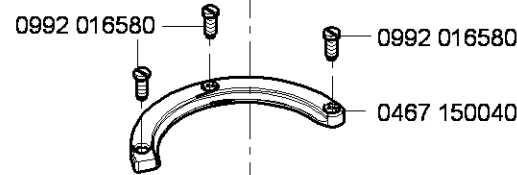

auf Wunsch
on request

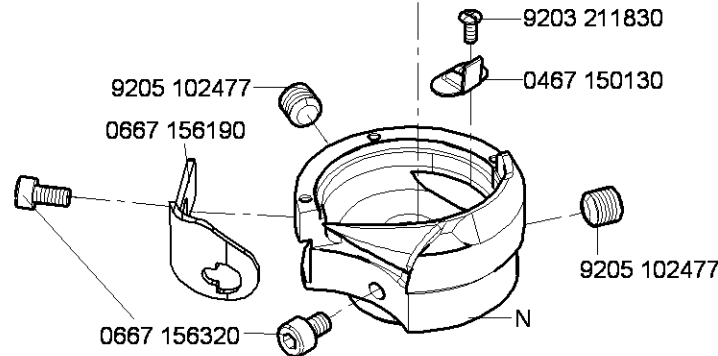
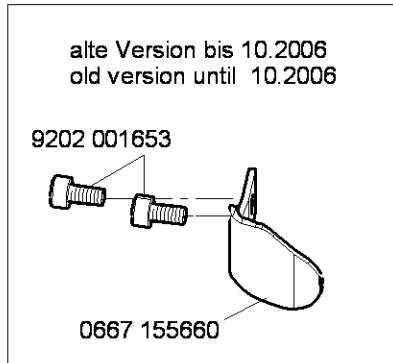

N - nicht als Einzelteil lieferbar
not available as separate part

auf Wunsch
on request

CI.867 -160122
CI.867 -260122

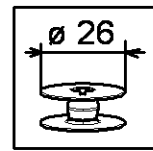

DLC - beschichtet für minimale ölschmierung
DLC - coated for minimal lubrication

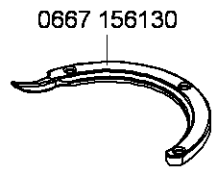
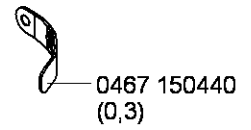
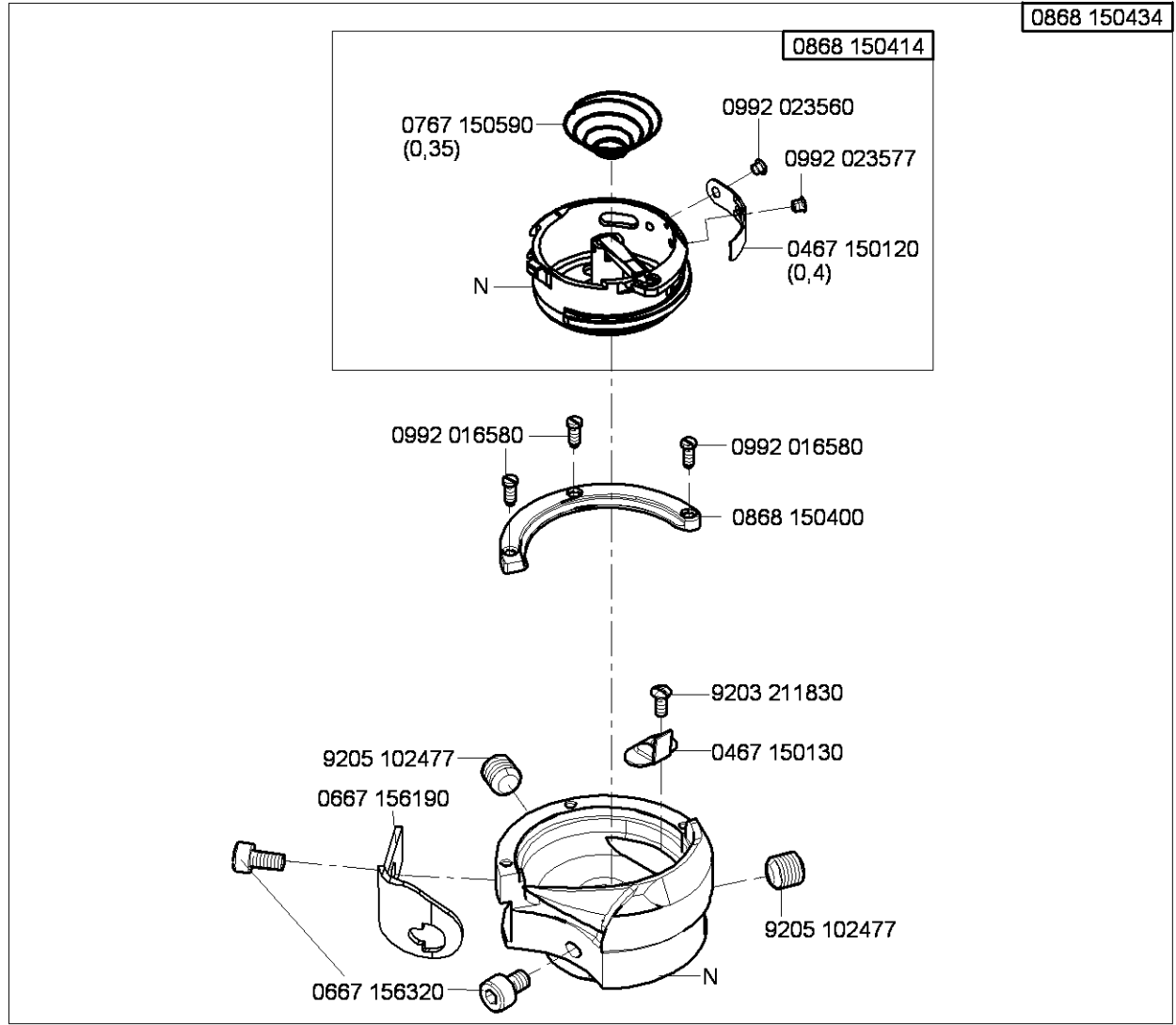

N - nicht als Einzelteil lieferbar
not available as separate part

auf Wunsch
on request

0667 150870
(0,45)

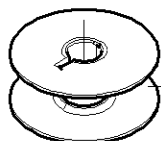

0667 150830

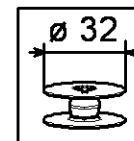

CI.867 -190040
CI.867 -190142
CI.867 -190342
CI.867 -290040
CI.867 -290142
CI.867 -290342

16

0667 155634

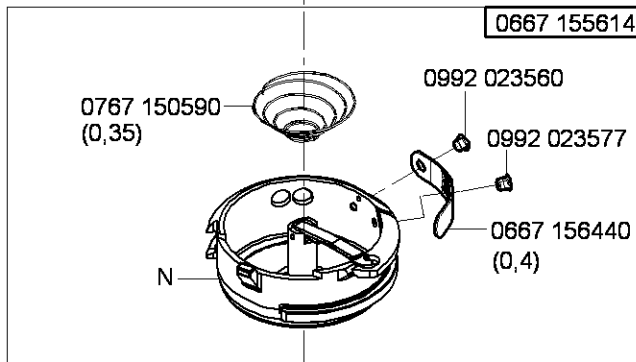

0767 150590
(0,35)

0992 023560

0992 023577

0667 156440
(0,4)

N

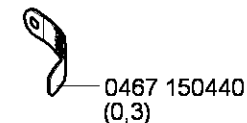

0467 150440
(0,3)

auf Wunsch
on request

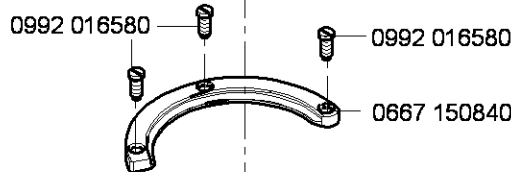

0992 016580

0992 016580

0667 150840

alte Version bis 10.2006
old version until 10.2006

9202 001653

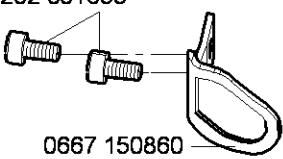

0667 150860

0667 156210

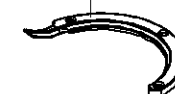

auf Wunsch
on request

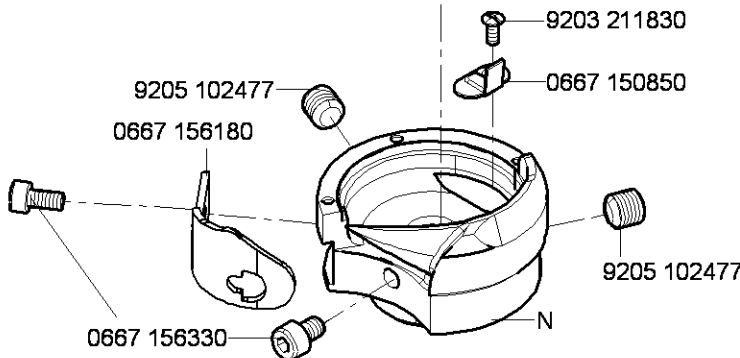

9205 102477

0667 156180

9203 211830

0667 150850

9205 102477

0667 156330

N

N - nicht als Einzelteil lieferbar
not available as separate part

auf Wunsch
on request

0667 150870
(0,45)

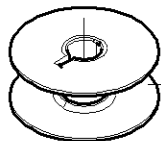

0667 150830

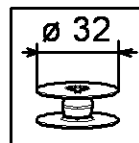
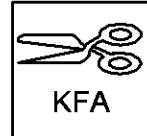

CI.867 -190145
CI.867 -190146
CI.867 -190445
CI.867 -290445

17

0667 156044

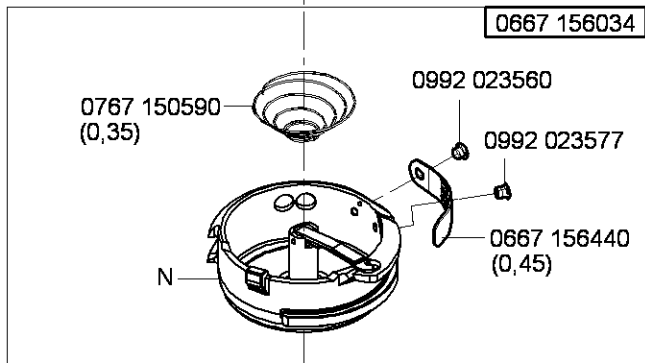

0767 150590
(0,35)

0992 023560

0992 023577

0667 156440
(0,45)

N



0467 150440
(0,3)

auf Wunsch
on request

0992 016580

0992 016580

0667 150840

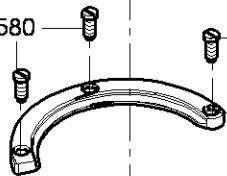

0667 156210

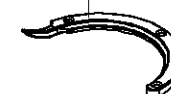

auf Wunsch
on request

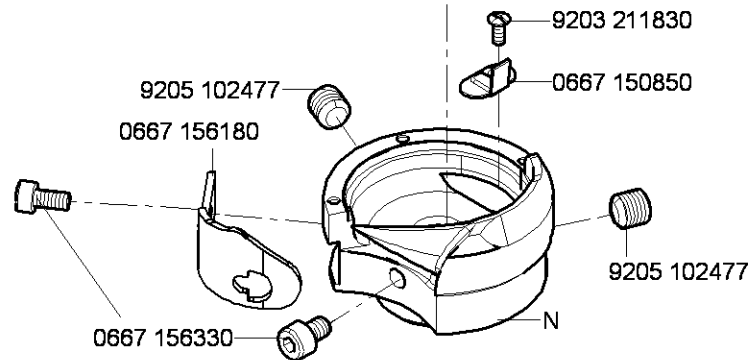

9205 102477

0667 156180

9203 211830

0667 150850

9205 102477

0667 156330

N

N - nicht als Einzelteil lieferbar
not available as separate part

auf Wunsch
on request

0667 150870
(0,45)

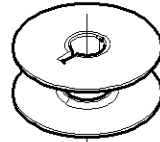

0667 150830

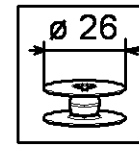
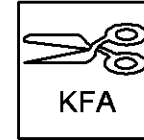

CI.867 -190125
CI.867 -190425

18

0867 150214

0867 150204

0767 150590
(0,35)

0992 023560

0992 023577

N

0467 150120
(0,4)



0467 150440
(0,3)

auf Wunsch
on request

0992 016580

0992 016580

0667 150840

0667 156210



auf Wunsch
on request

9203 211830

0667 150850

9205 102477

0667 156190

9205 102477

0667 156330

N

N - nicht als Einzelteil lieferbar
not available as separate part

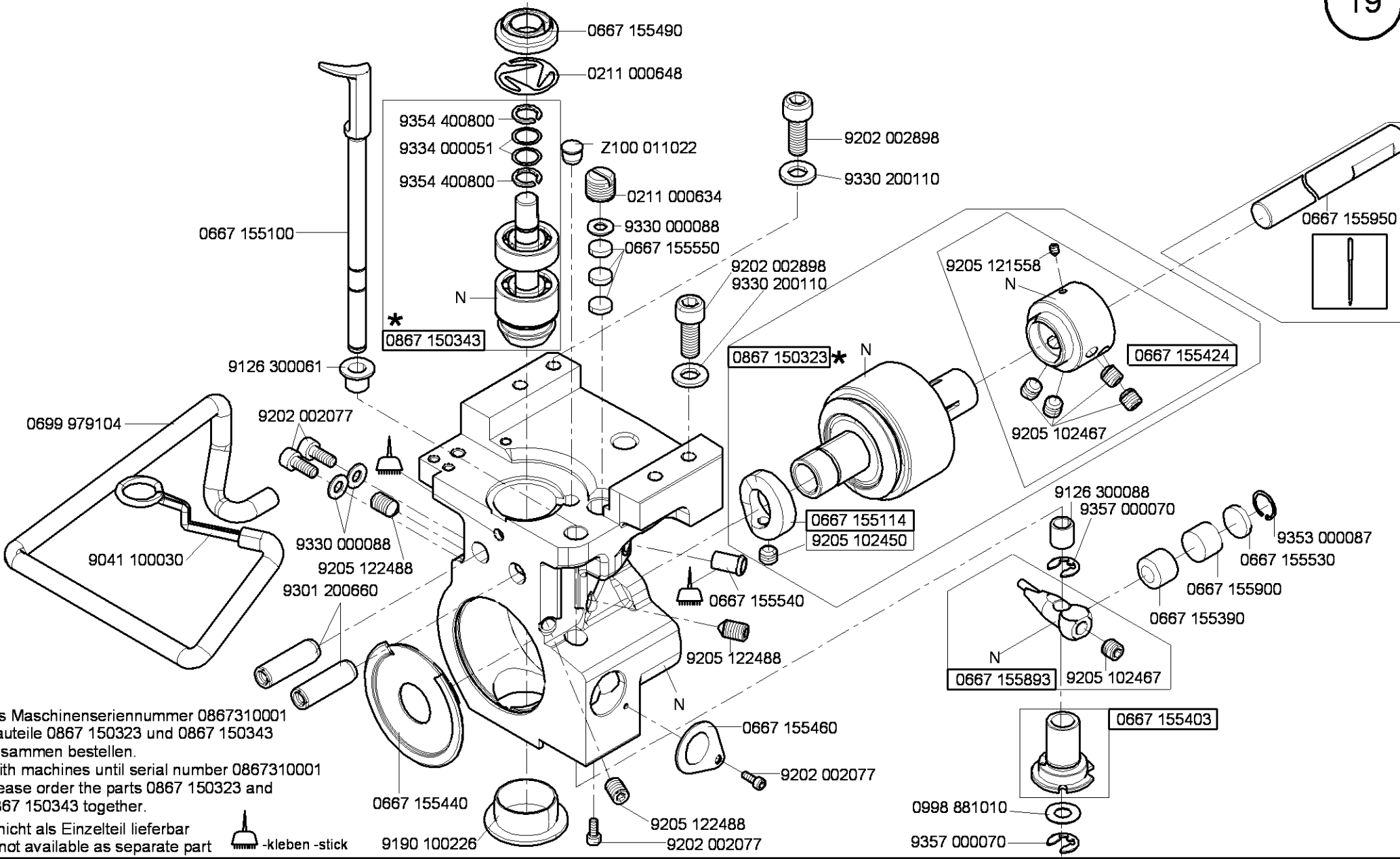

* Bis Maschinenseriennummer 0867310001
 Bauteile 0867 150323 und 0867 150343
 zusammen bestellen.
 With machines until serial number 0867310001
 please order the parts 0867 150323 and
 0867 150343 together.

N - nicht als Einzelteil lieferbar
 not available as separate part



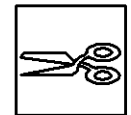

- CI.867 -160122
- CI.867 -190122
- CI.867 -190142
- CI.867 -190322
- CI.867 -190342
- CI.867 -260122
- CI.867 -290122
- CI.867 -290142
- CI.867 -290322
- CI.867 -290342

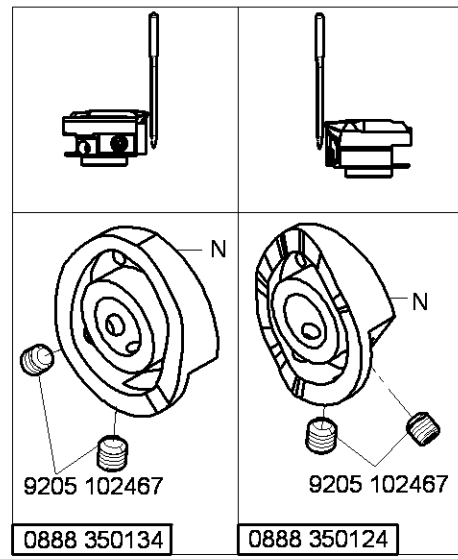
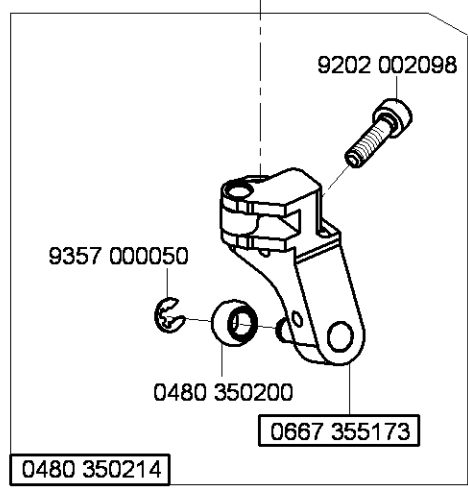
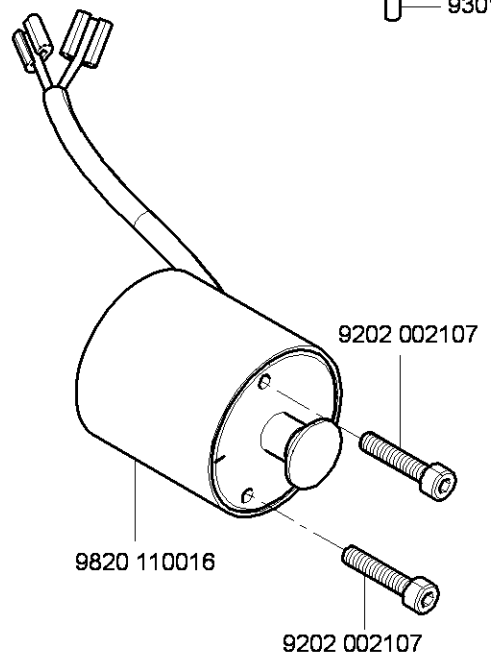
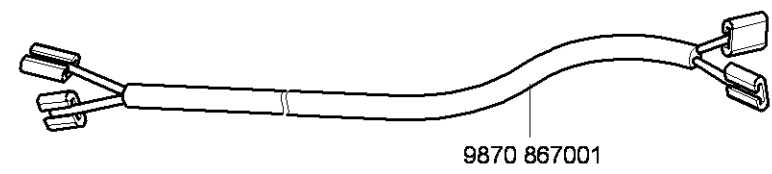
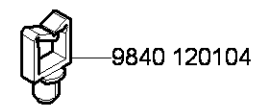
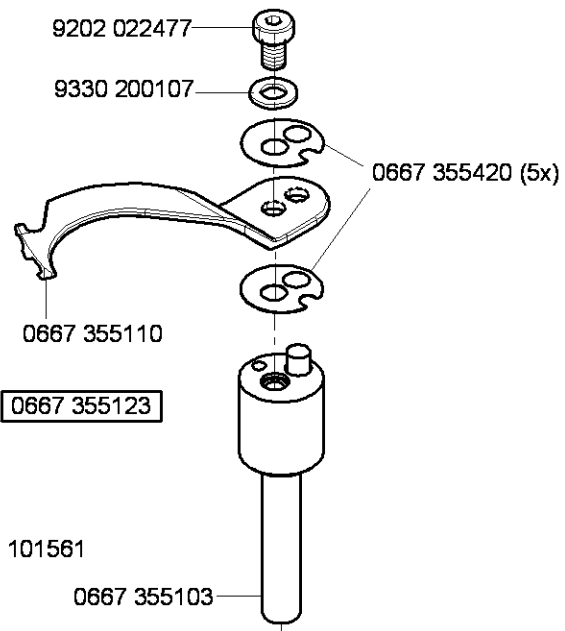
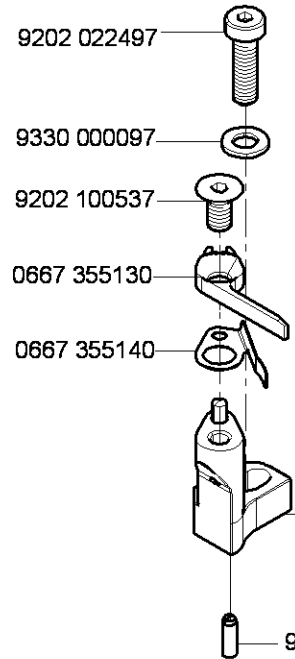

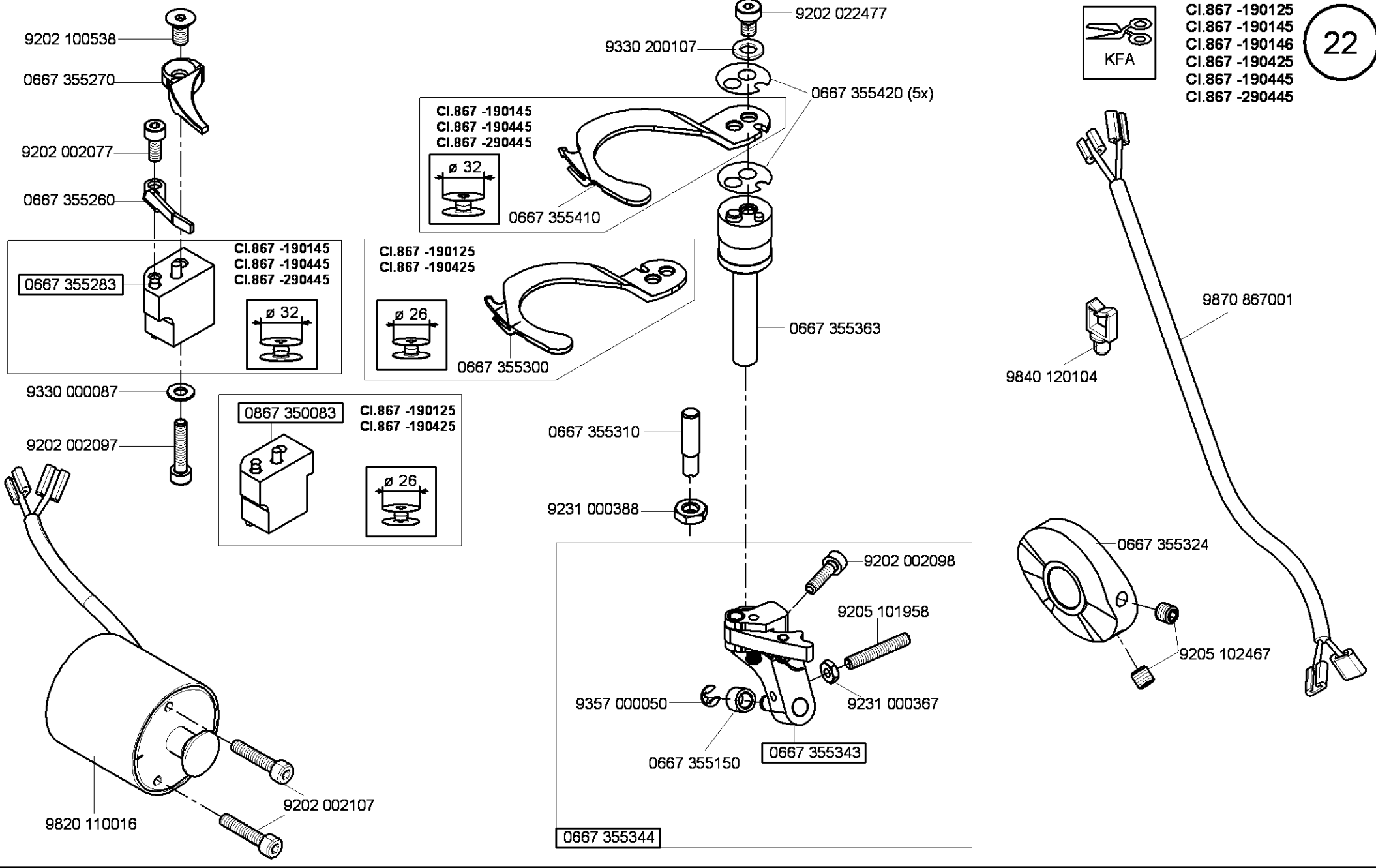

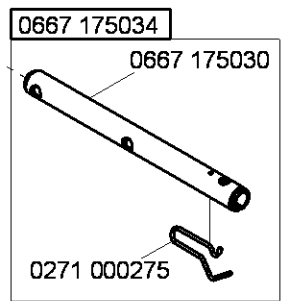
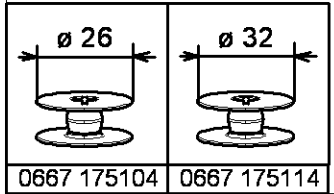
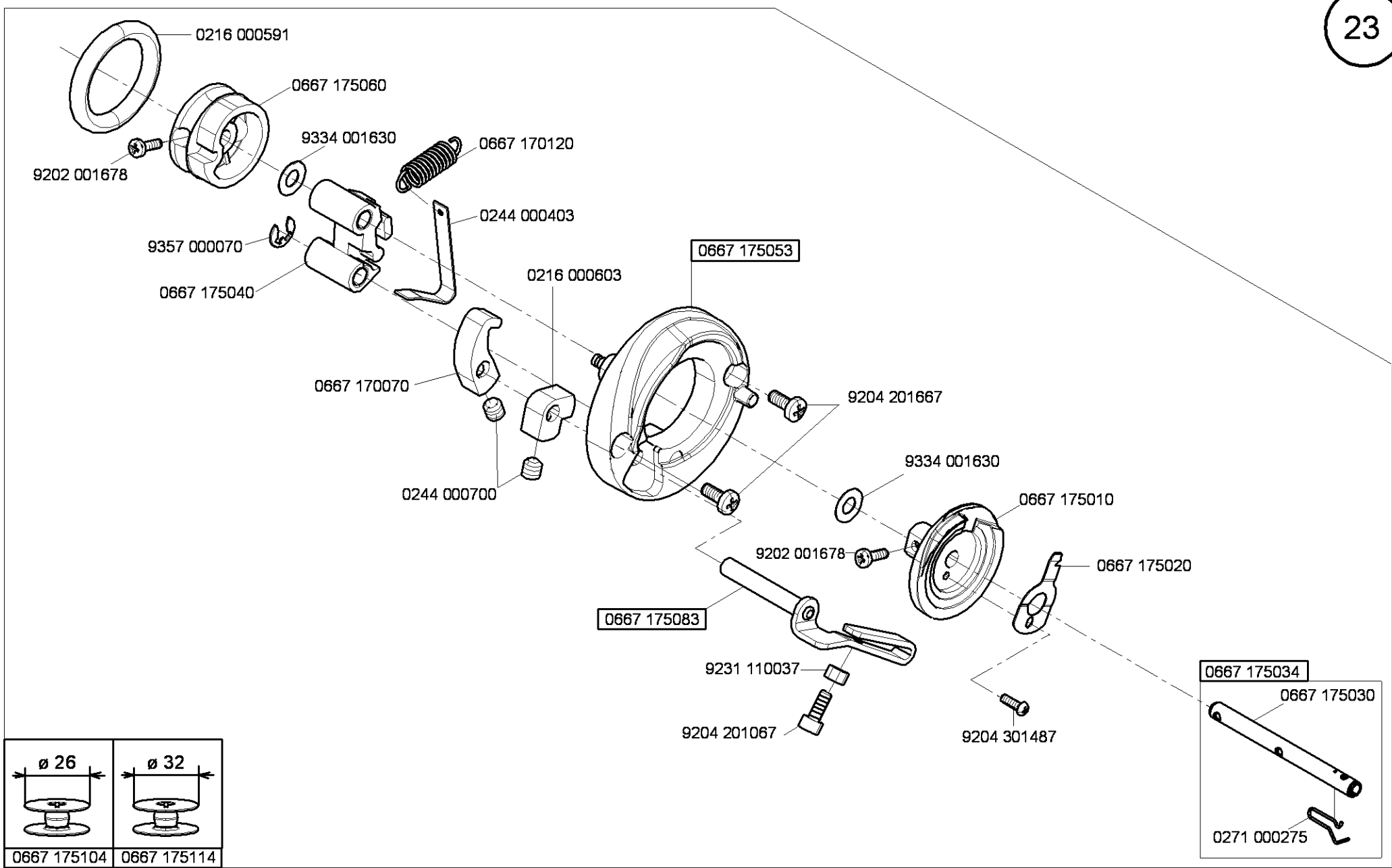

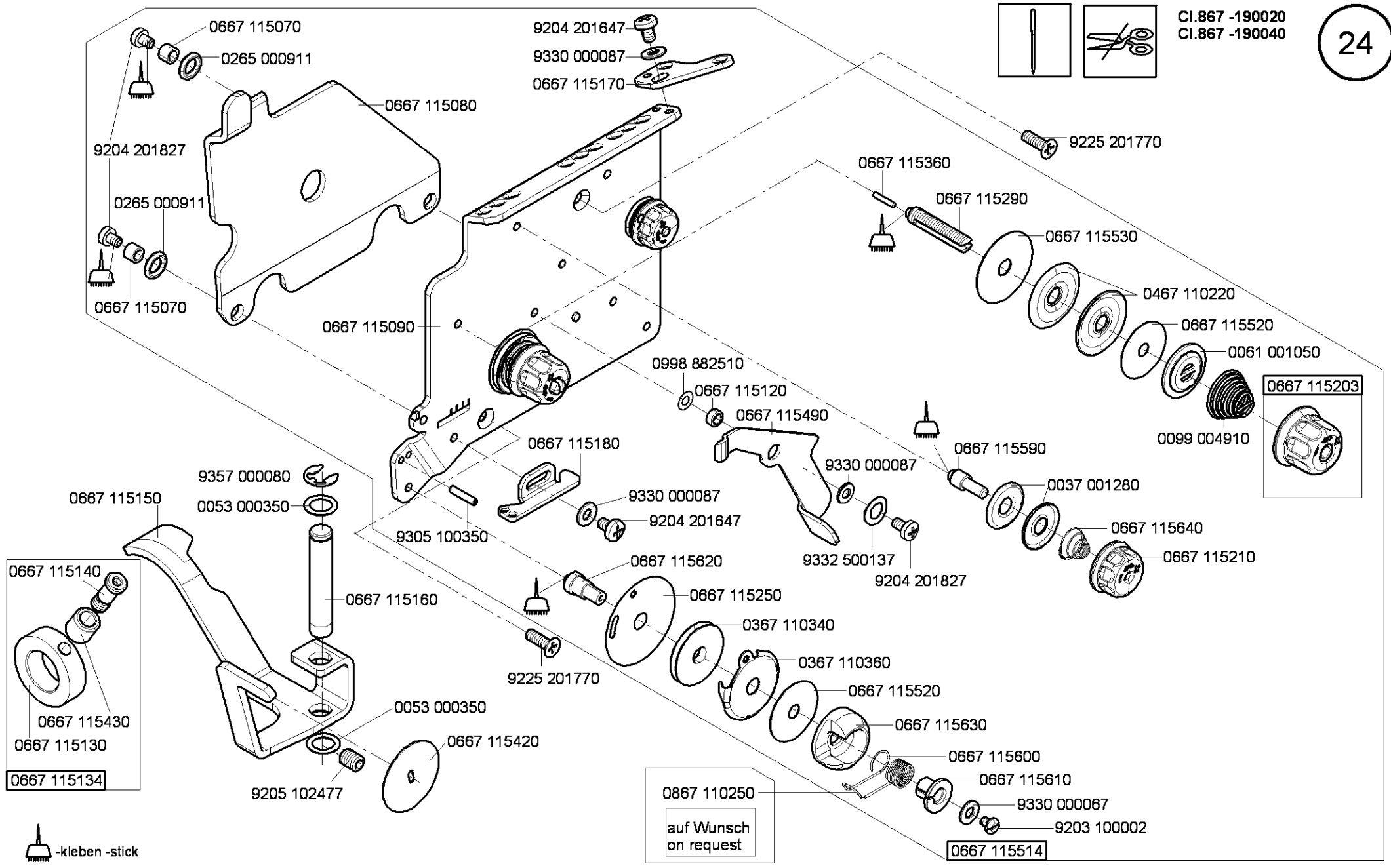
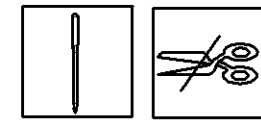

0667 115134

0667 115130
0667 115430

-kleben -stick

0867 110250
auf Wunsch
on request

0667 115514

0667 115203

CI.867 -190322
CI.867 -190342
CI.867 -190425
CI.867 -190445

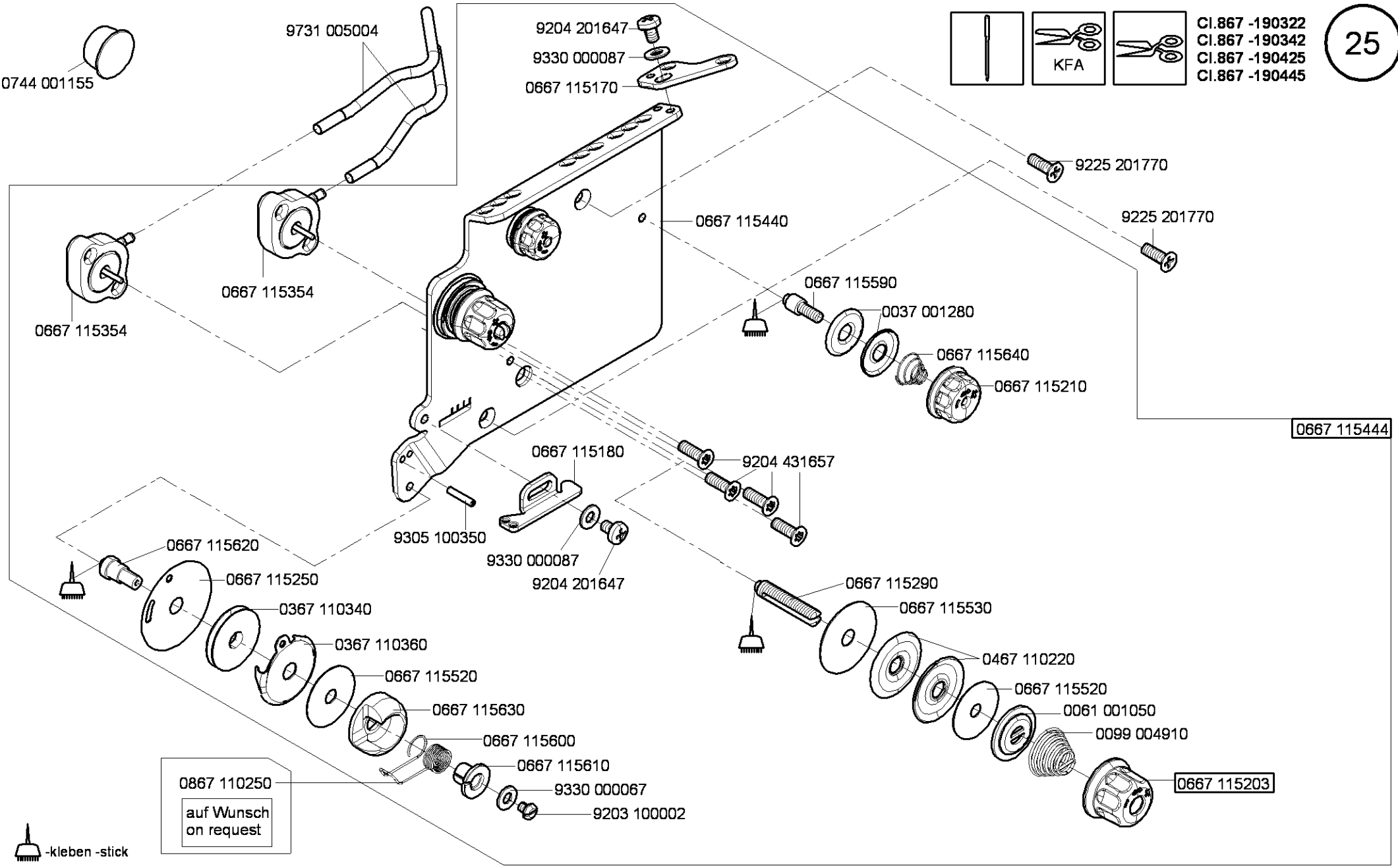
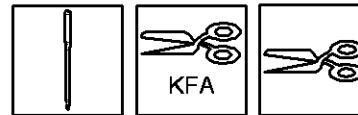

0867 110250
auf Wunsch
on request

-kleben -stick

CI.867 -160122
CI.867 -190122
CI.867 -190125
CI.867 -190142
CI.867 -190145

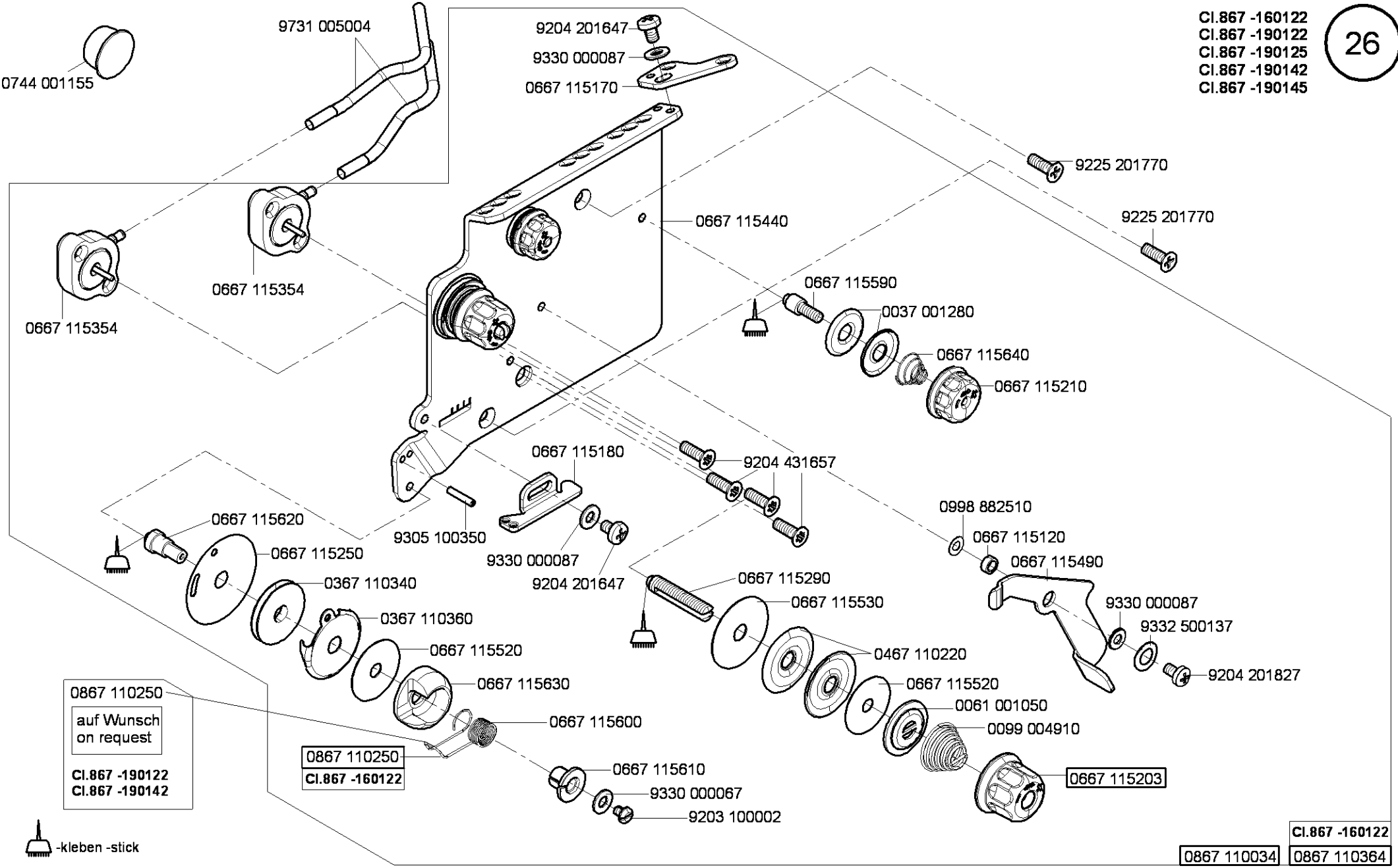

0867 110250
auf Wunsch
on request
CI.867 -190122
CI.867 -190142

0867 110250
CI.867 -160122

-kleben -stick

CI.867 -160122
0867 110034 0867 110364

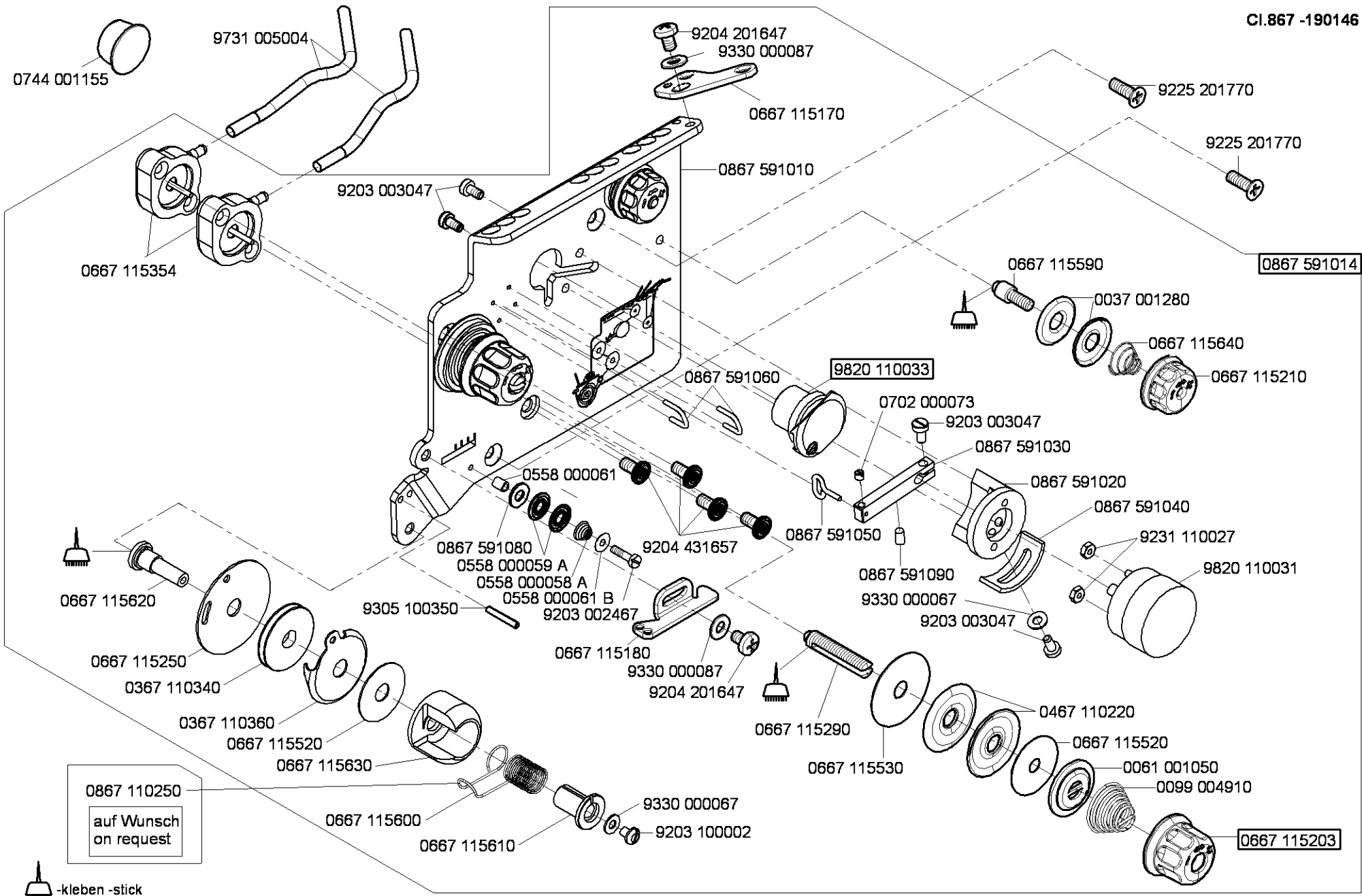

0867 110250
auf Wunsch
on request

 -kleben -stick

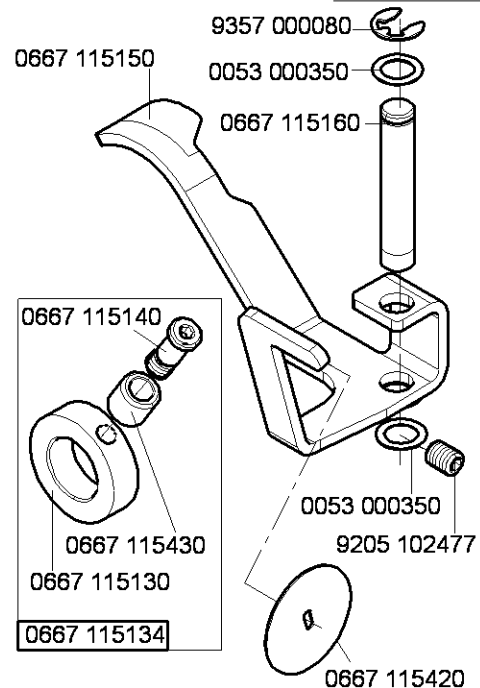
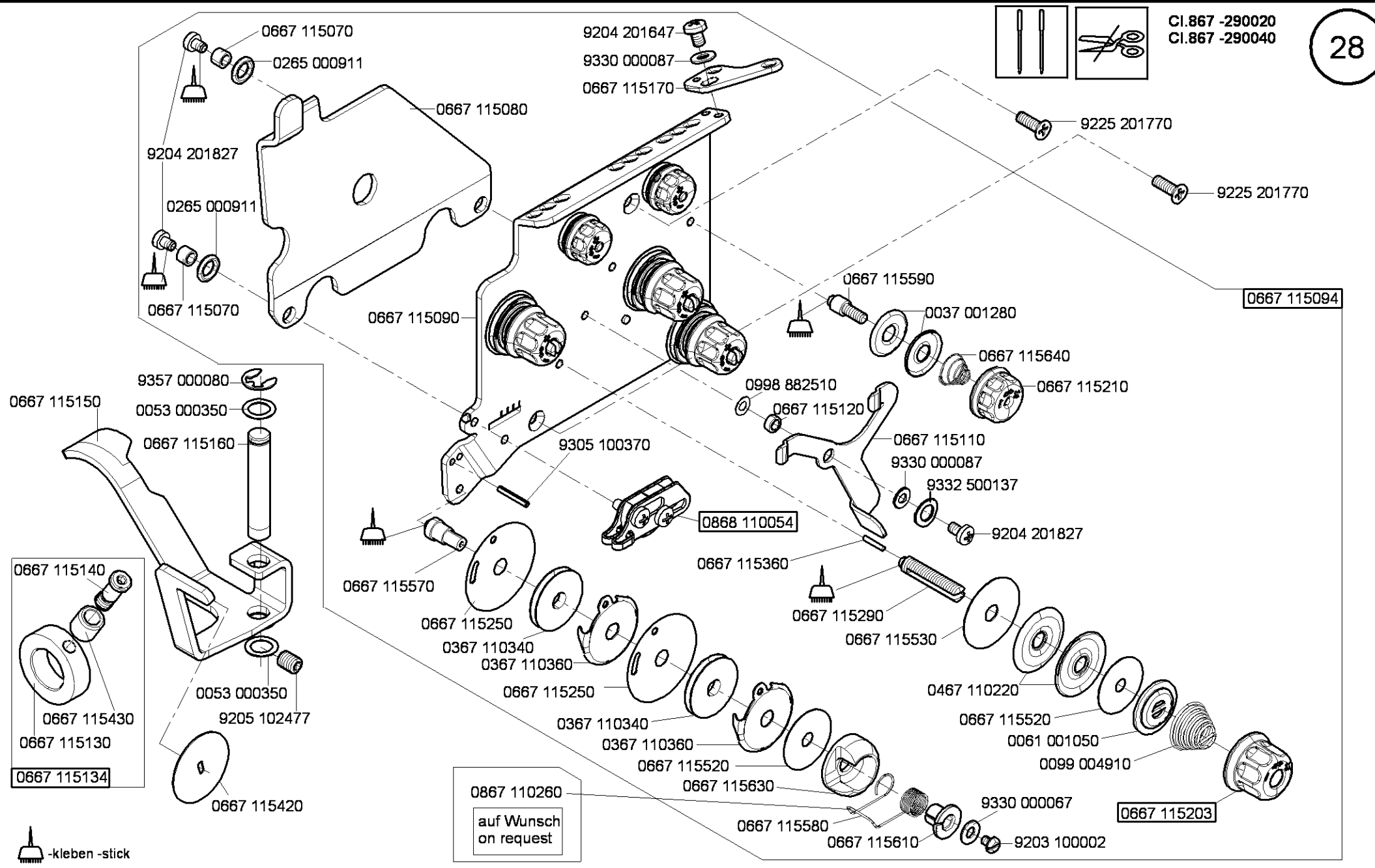
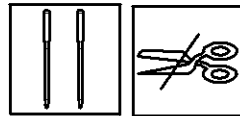

-kleben -stick

0867 110260
auf Wunsch
on request

Cl.867 -290322
Cl.867 -290342
Cl.867 -290445

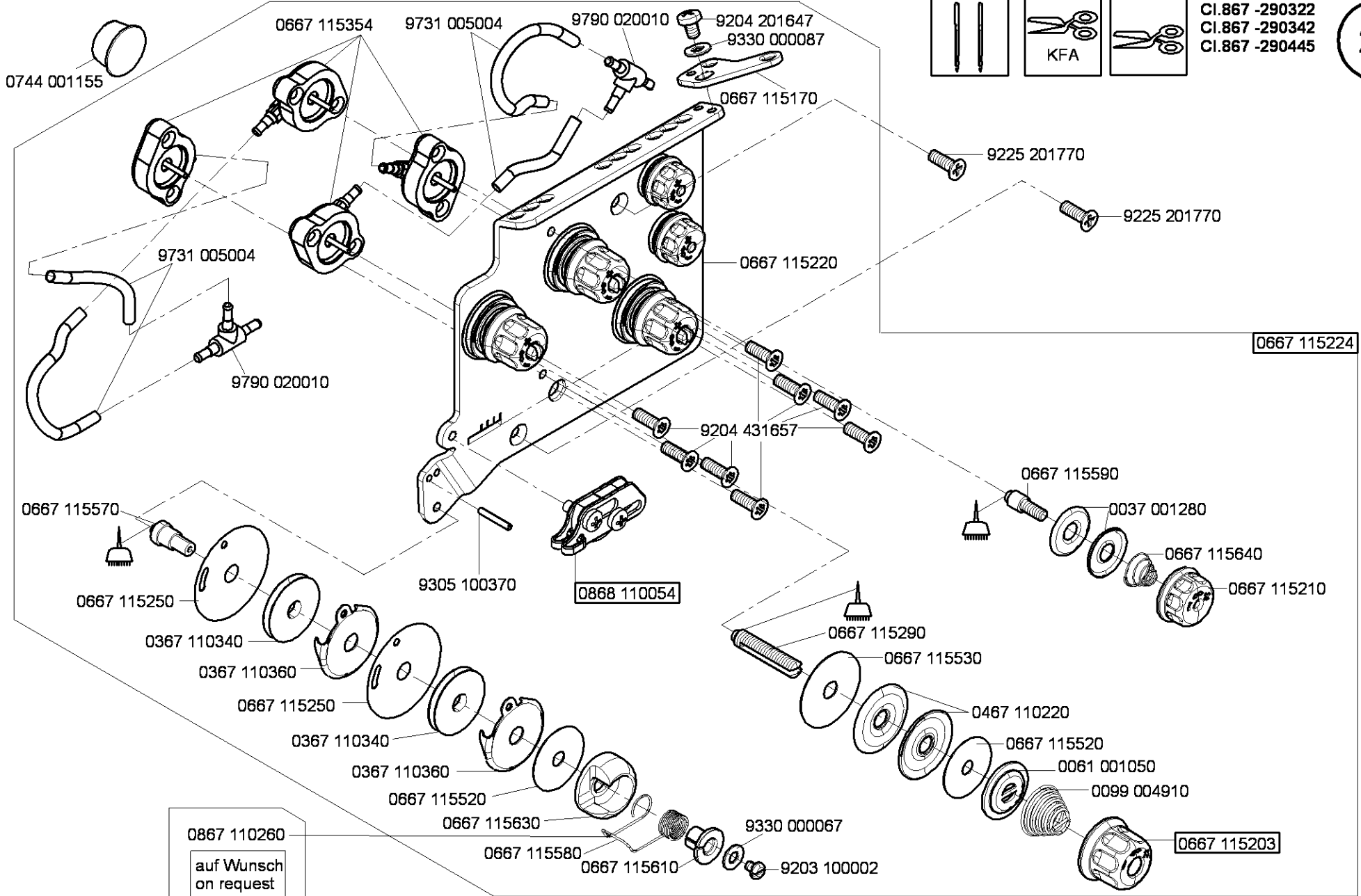
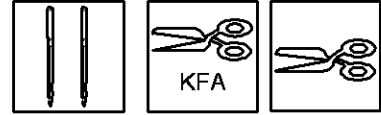

0867 110260
auf Wunsch
on request

 -kleben -stick

CI.867 -260122
CI.867 -290122
CI.867 -290142

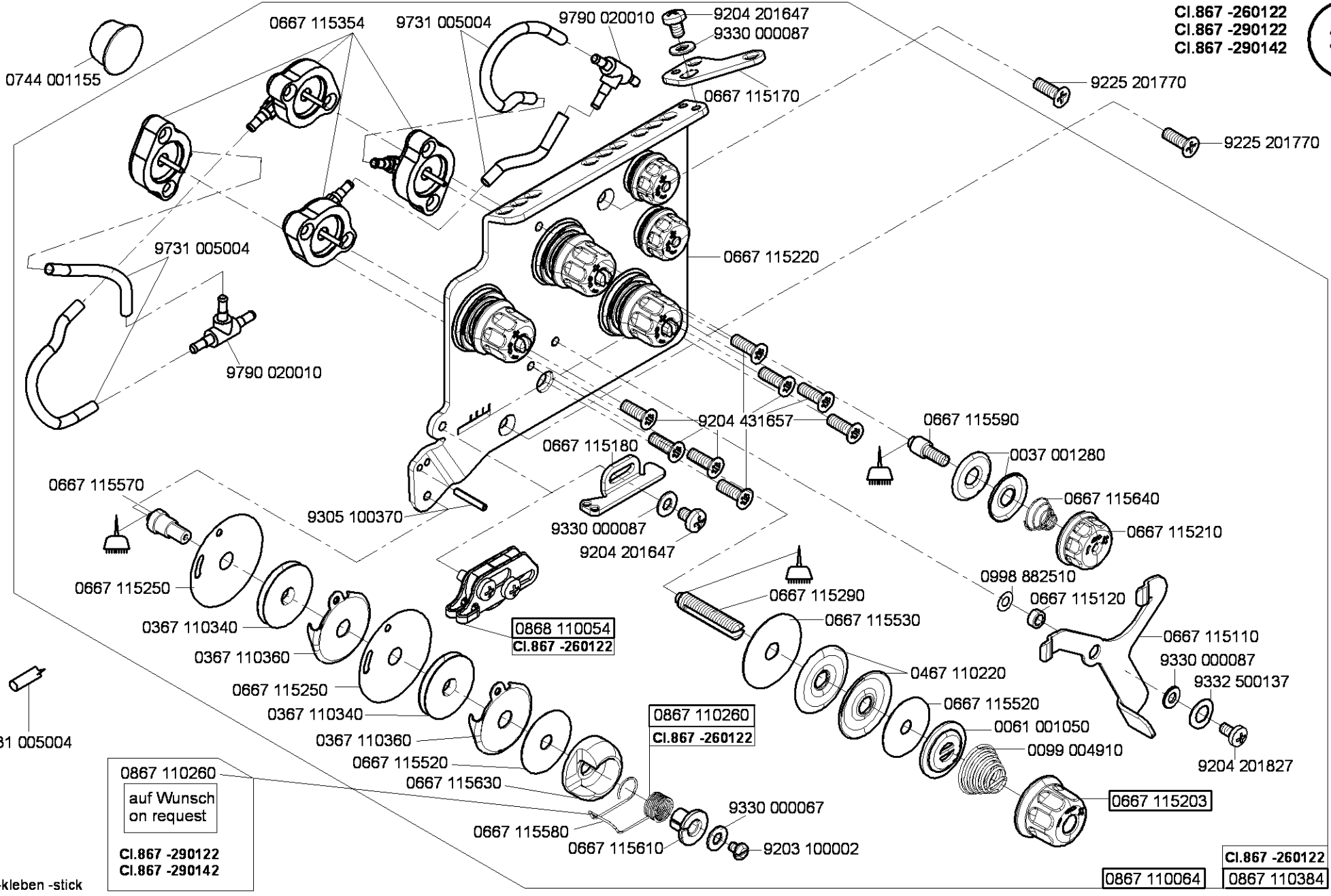

-kleben -stick

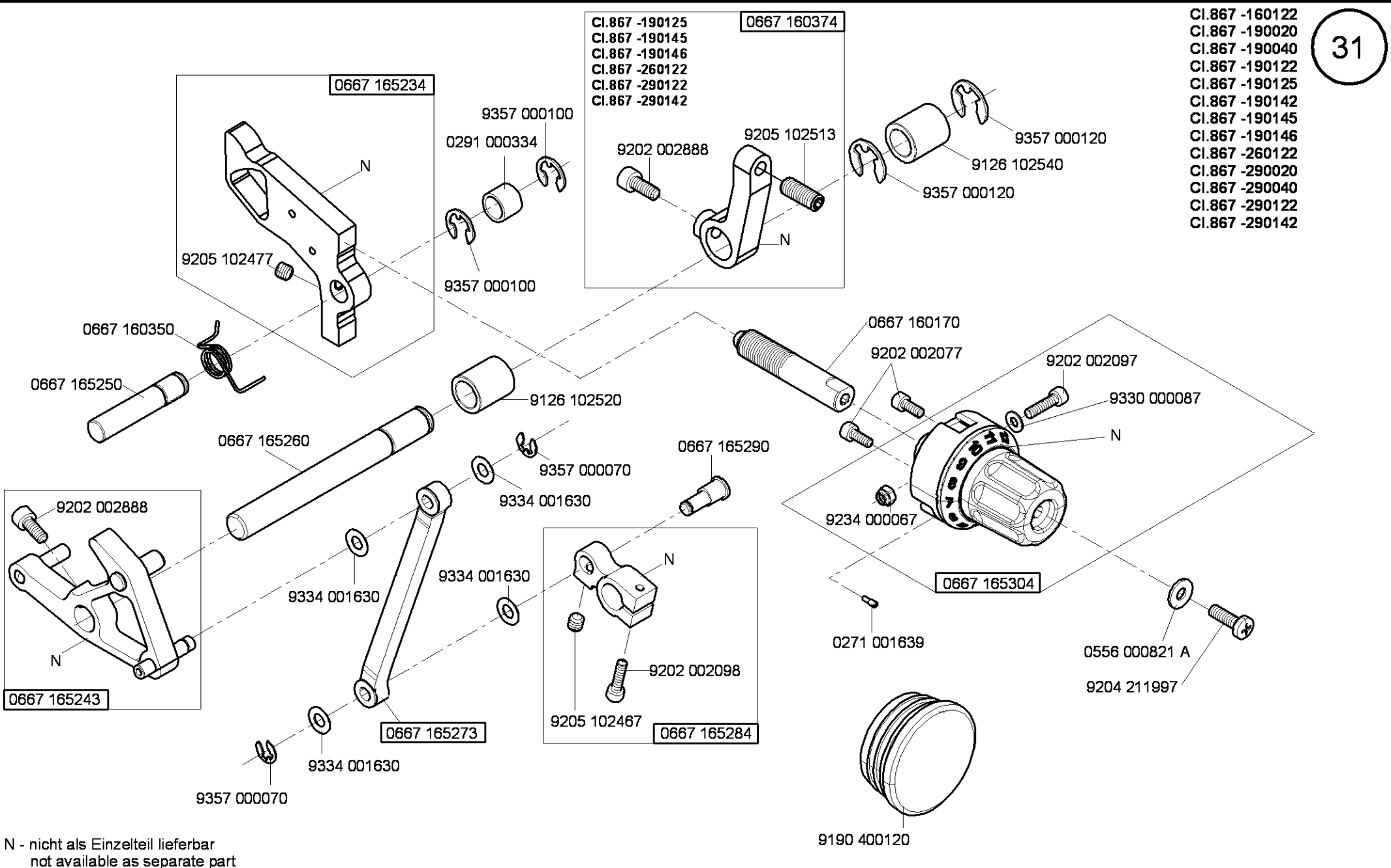

CI.867 -190125
 CI.867 -190145
 CI.867 -190146
 CI.867 -260122
 CI.867 -290122
 CI.867 -290142

CI.867 -160122
 CI.867 -190020
 CI.867 -190040
 CI.867 -190122
 CI.867 -190125
 CI.867 -190142
 CI.867 -190145
 CI.867 -190146
 CI.867 -260122
 CI.867 -290020
 CI.867 -290040
 CI.867 -290122
 CI.867 -290142

N - nicht als Einzelteil lieferbar
 not available as separate part

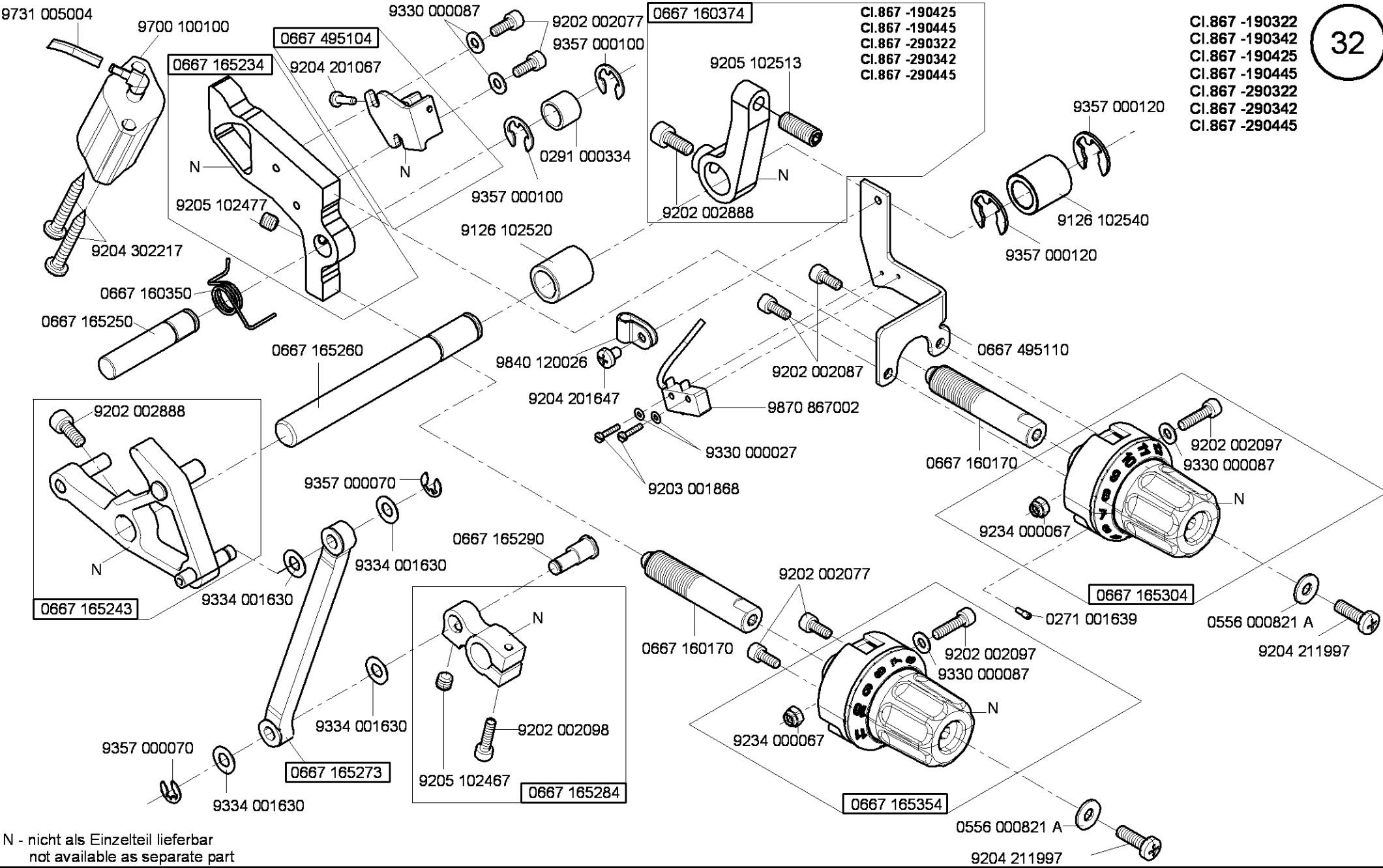

N - nicht als Einzelteil lieferbar
not available as separate part

- CI.867 -190020
- CI.867 -190040
- CI.867 -190322
- CI.867 -190342
- CI.867 -290020
- CI.867 -290040
- CI.867 -290322
- CI.867 -290342

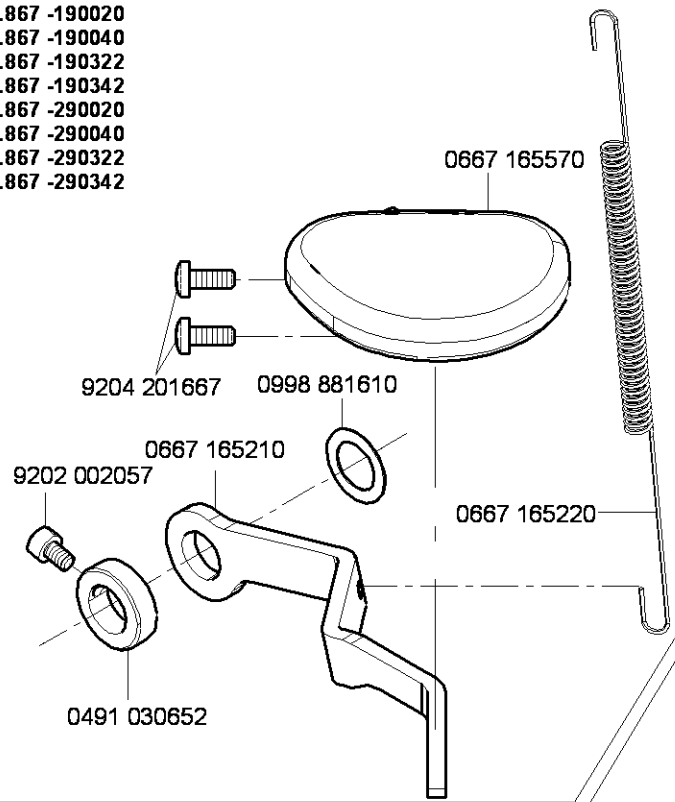

0867 590464
auf Wunsch
on request

- CI.867 -160122
- CI.867 -190122
- CI.867 -190142
- CI.867 -260122
- CI.867 -290122
- CI.867 -290142

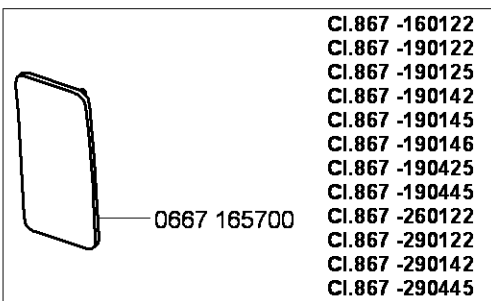

- CI.867 -160122
- CI.867 -190122
- CI.867 -190125
- CI.867 -190142
- CI.867 -190145
- CI.867 -190146
- CI.867 -190425
- CI.867 -190445
- CI.867 -260122
- CI.867 -290122
- CI.867 -290142
- CI.867 -290445

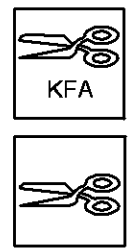

- CI.867 -160122
- CI.867 -190122
- CI.867 -190125
- CI.867 -190142
- CI.867 -190145
- CI.867 -190146
- CI.867 -190322
- CI.867 -190342
- CI.867 -190425
- CI.867 -190445
- CI.867 -260122
- CI.867 -290122
- CI.867 -290142
- CI.867 -290322
- CI.867 -290342
- CI.867 -290445

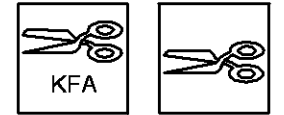
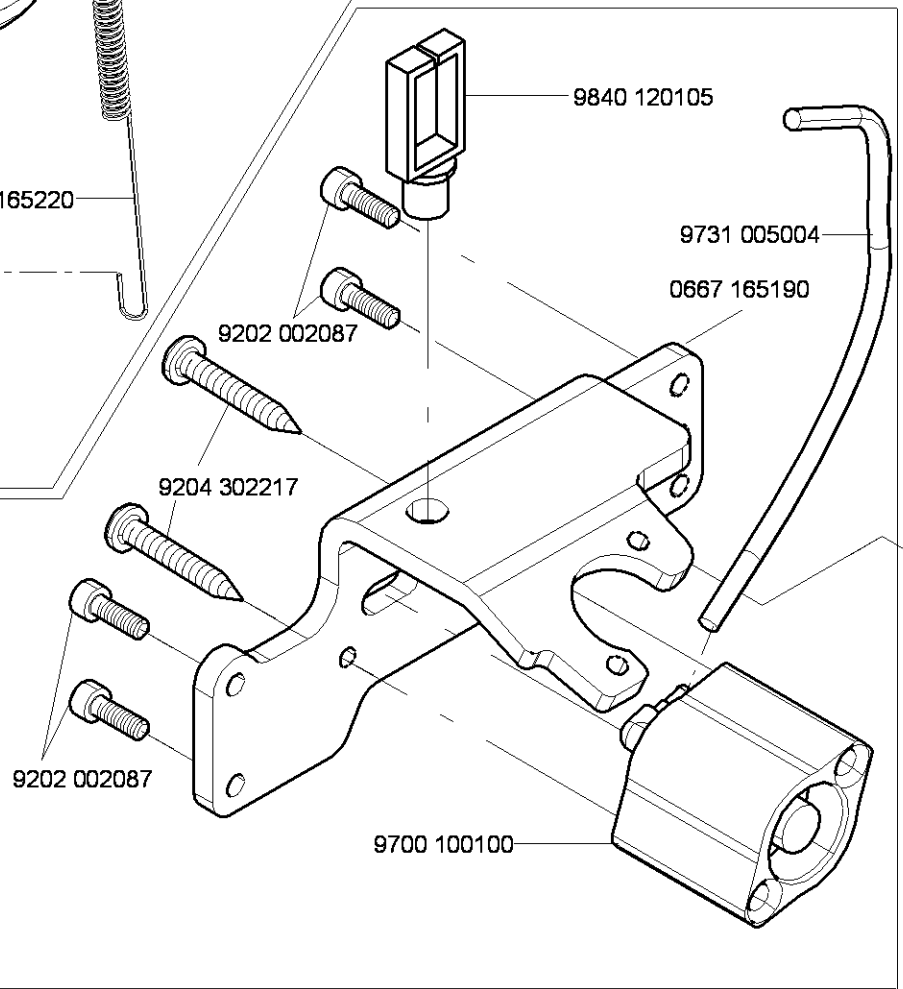

- CI.867 -190125
- CI.867 -190145
- CI.867 -190146
- CI.867 -190425
- CI.867 -190445
- CI.867 -260122
- CI.867 -290122
- CI.867 -290142
- CI.867 -290322
- CI.867 -290342
- CI.867 -290445

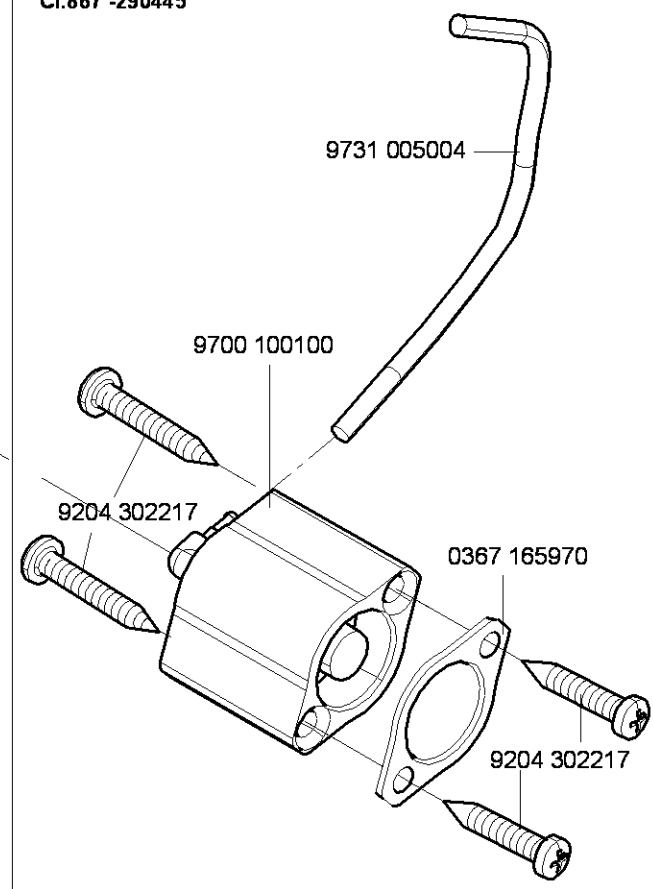

9880 867101

9199 000004

9850 867000

9204 201067

9204 301467

9204 201667

9830 501010

0867 490400

9830 501010

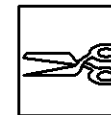

CI.867 -190322
CI.867 -190342

34

9204 201667

9825 550001

N

9204 301467

9815 310009

9815 301081

9815 301096

9815 301091

9815 301079

9815 301090

9815 310008 (6x)

0667 495133

0667 495093

9204 201667

9710 920012

9790 201000

0911 000478

0570 001847

9204 201667

0667 495290

0570 001847

9710 982006

9710 900047

9710 061200

9204 200517

9710 900011

9204 200447

9790 200000

9731 005004

N - nicht als Einzelteil lieferbar
not available as separate part

CI. 867 Standard

9880 867101

9199 000004

9850 867000

9204 201067

9204 301467

9204 201667

9830 501010

0867 490400

9204 201667

9830 501010

9204 201667

9825 550001

N

9204 301467

9815 310009

9815 301081

9815 301096

9815 301091

9815 301079

9815 301090

9815 310008 (6x)

0667 495133

9790 201000

0911 000478

0570 001847

0667 495290

9790 200000

9204 201667

9710 920012

9790 201000

9710 061200 (7x)

9710 982006

9710 900047

N

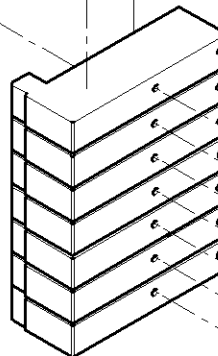

9204 200517 (14x)

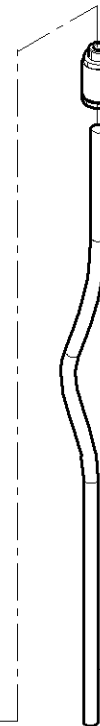
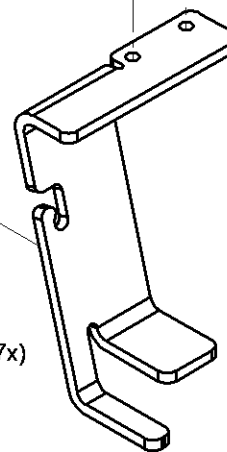

9731 005004

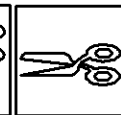
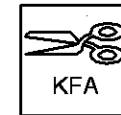

CI.867 -190425
CI.867 -190445
CI.867 -290322
CI.867 -290342
CI.867 -290445

35

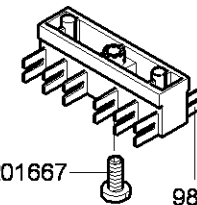

N - nicht als Einzelteil lieferbar
not available as separate part

CI.867 -190125
CI.867 -190145
CI.867 -190146
CI.867 -260122
CI.867 -290122
CI.867 -290142

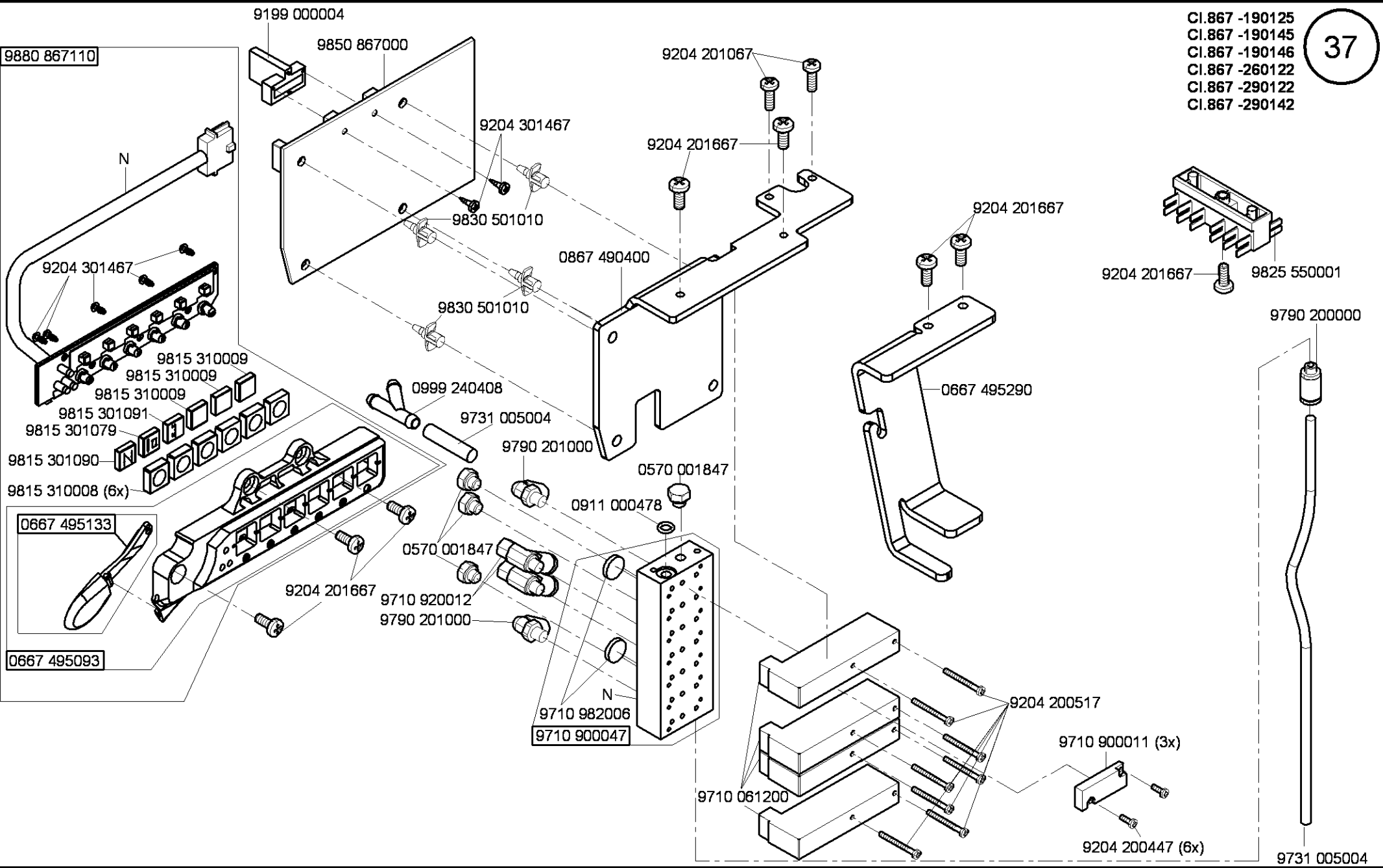

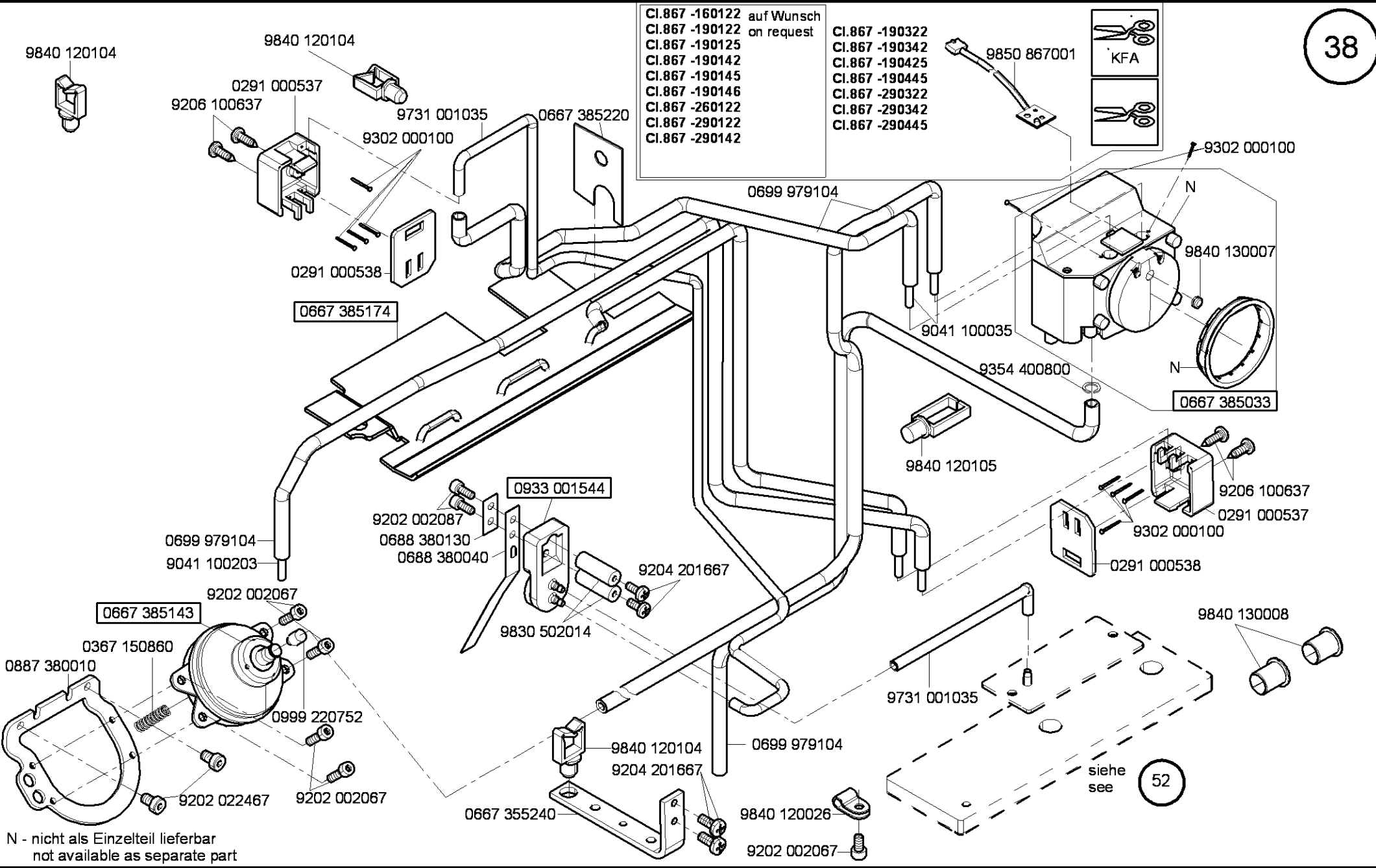

N - nicht als Einzelteil lieferbar
not available as separate part

CI. 867 Standard

9880 867102

- 0667 495304
- 9840 120003 (8x)
- 9840 123003 (8x)
- 9840 121001 (5x)
- 9840 133013
- 9840 133012
- 9840 135012
- 9840 132015
- 9840 120026 (2x)
- 9202 002077 (3x)
- 9207 170437 (2x)
- 9840 104001 (2x)

- CI.867 -190322
- CI.867 -190342
- CI.867 -190425
- CI.867 -190445
- CI.867 -290322
- CI.867 -290342
- CI.867 -290445

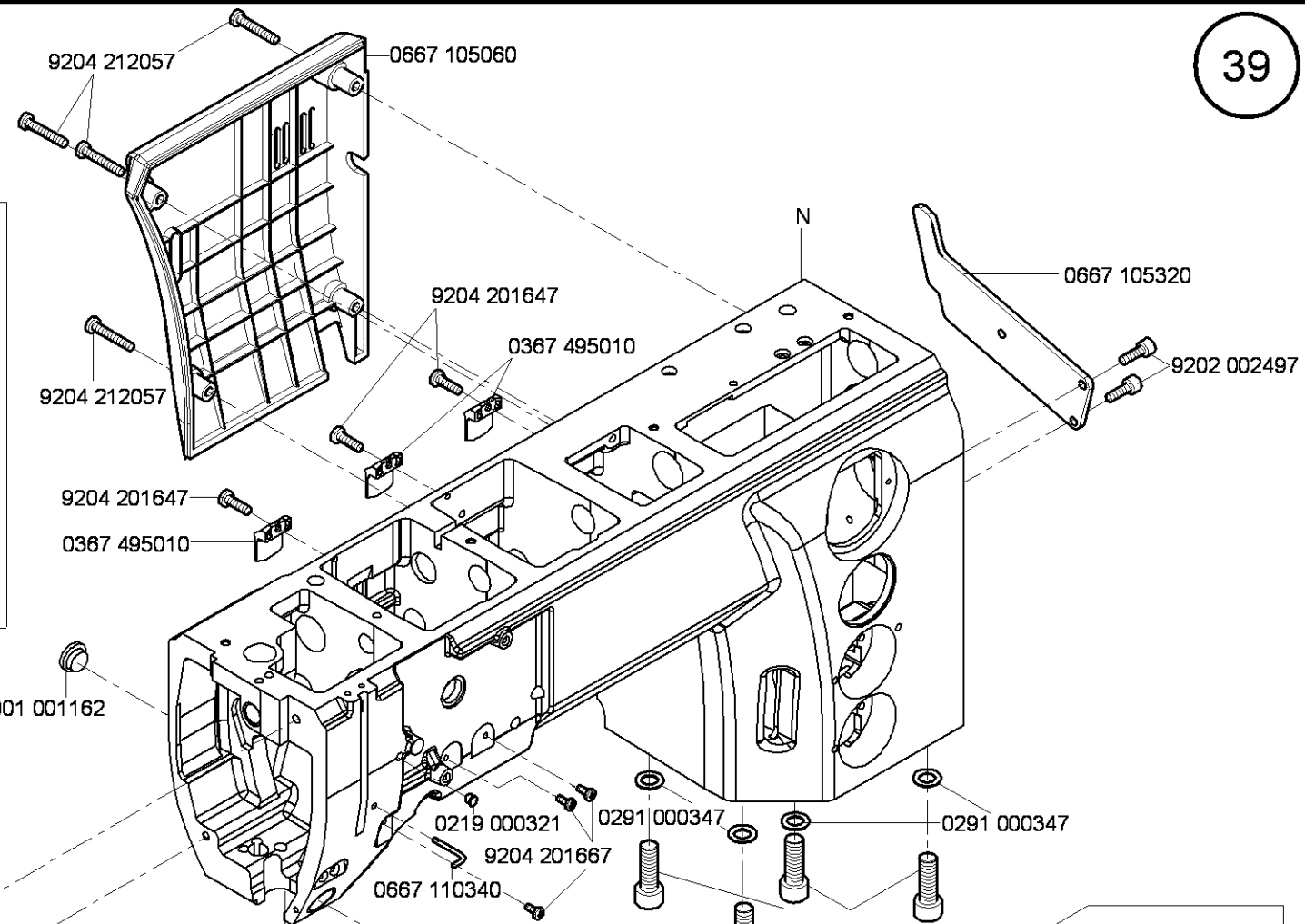

0667 105144

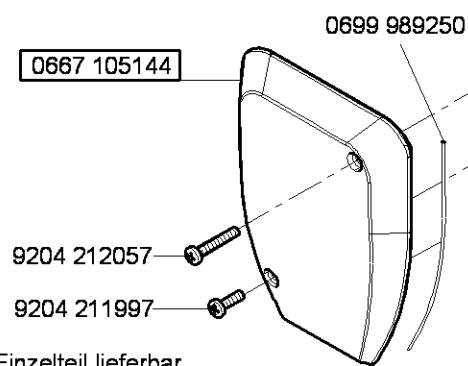

- CI.867 -160122
- CI.867 -190020
- CI.867 -190040
- CI.867 -190122
- CI.867 -190125
- CI.867 -190142
- CI.867 -190145
- CI.867 -190146
- CI.867 -260122
- CI.867 -290020
- CI.867 -290040
- CI.867 -290122
- CI.867 -290142

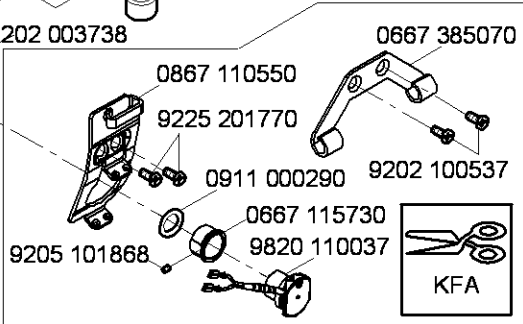
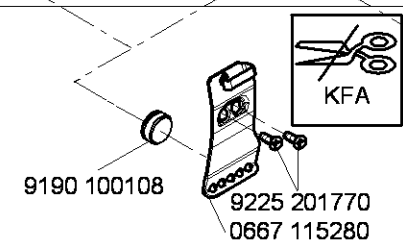
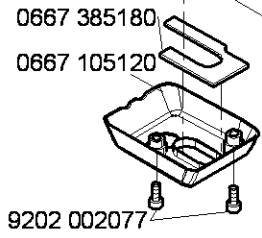

N - nicht als Einzelteil lieferbar
not available as separate part

- CI.867 -160122
- CI.867 -190020
- CI.867 -190040
- CI.867 -190122
- CI.867 -190125
- CI.867 -190142
- CI.867 -190145
- CI.867 -190146
- CI.867 -260122
- CI.867 -290020
- CI.867 -290040
- CI.867 -290122
- CI.867 -290142

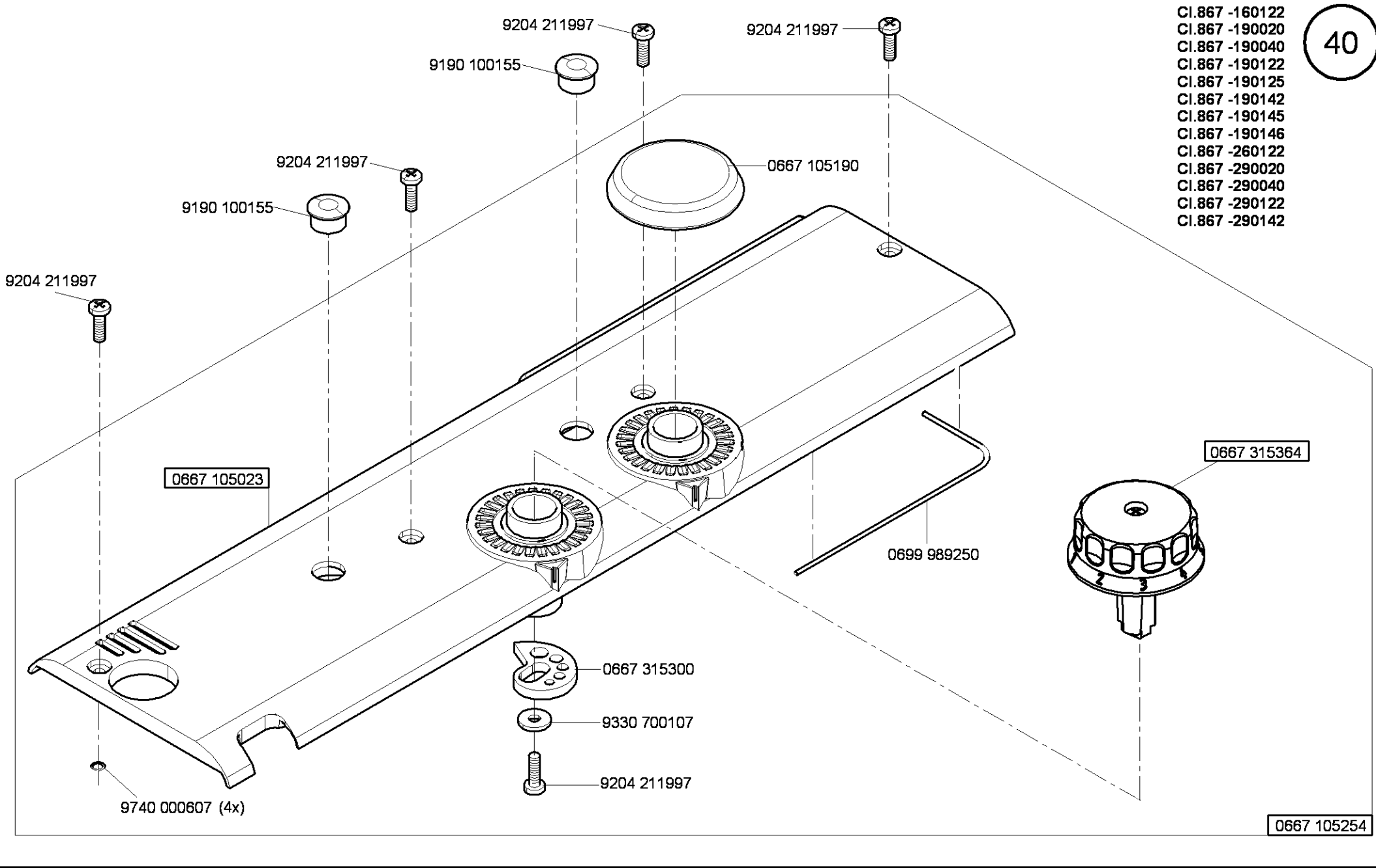

CI. 867 Standard

0667 105254

CI.867 -190322
CI.867 -190342
CI.867 -290322
CI.867 -290342

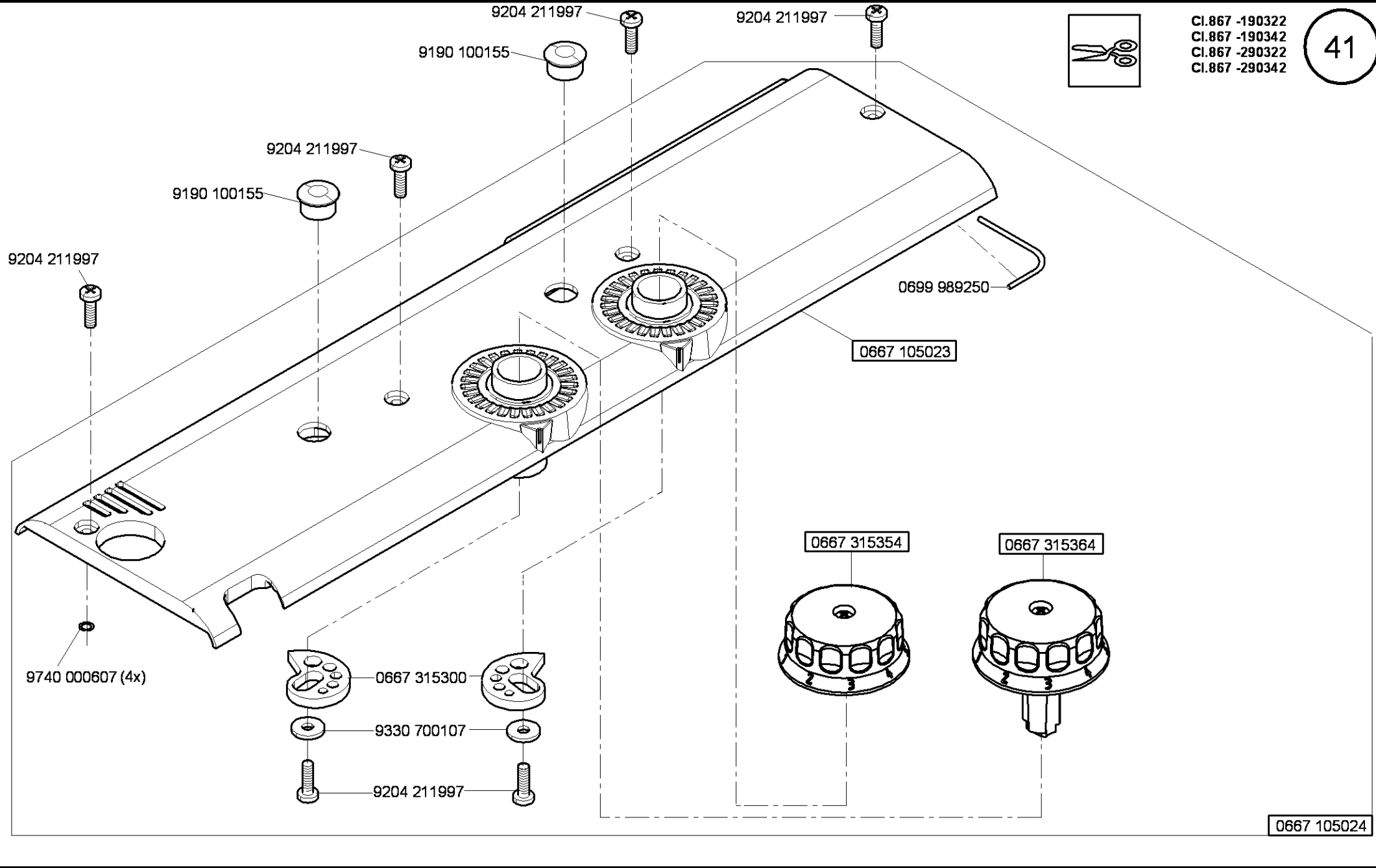
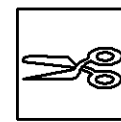

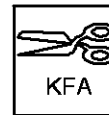

Cl. 867 -190425
 Cl. 867 -190445
 Cl. 867 -290445

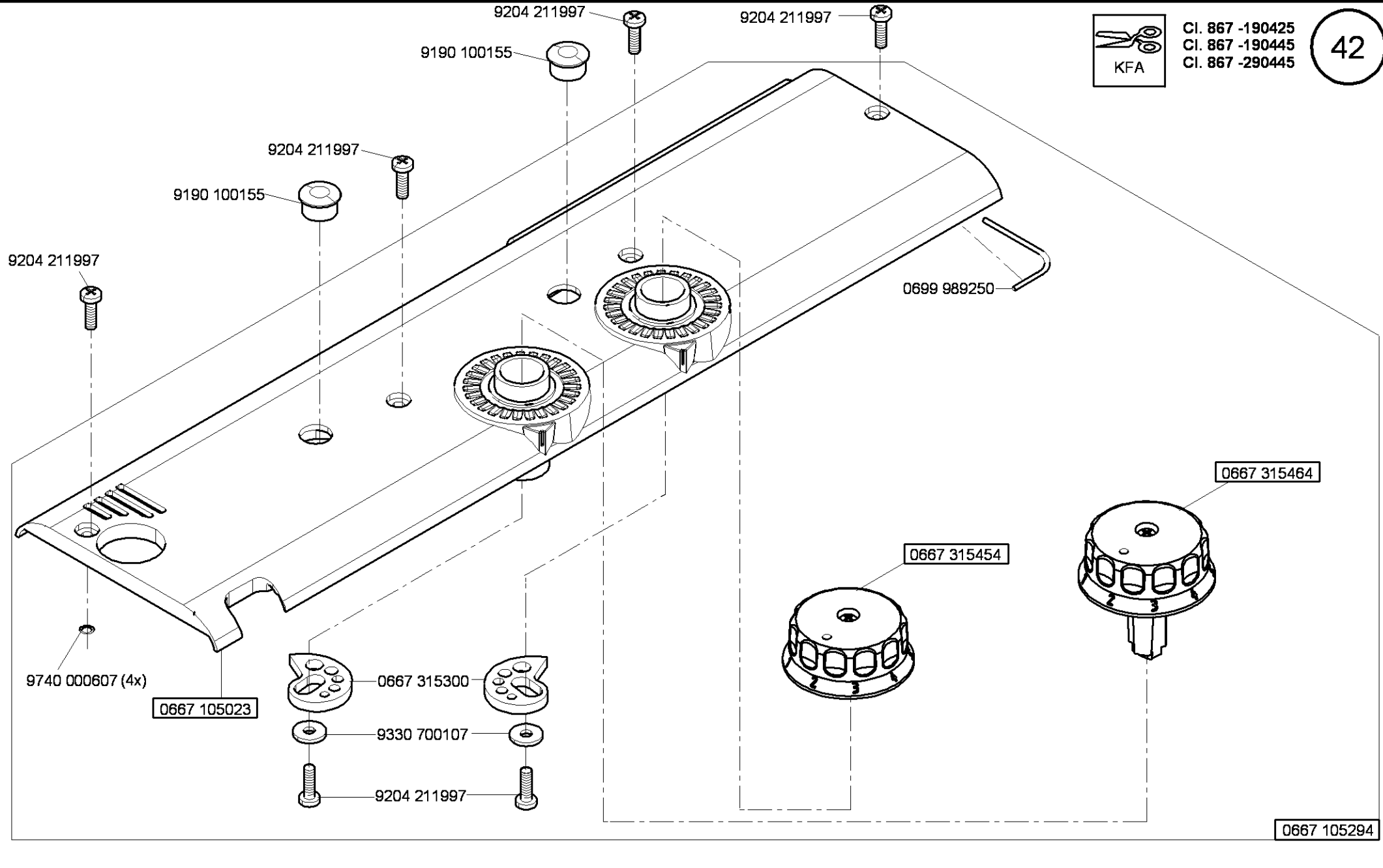

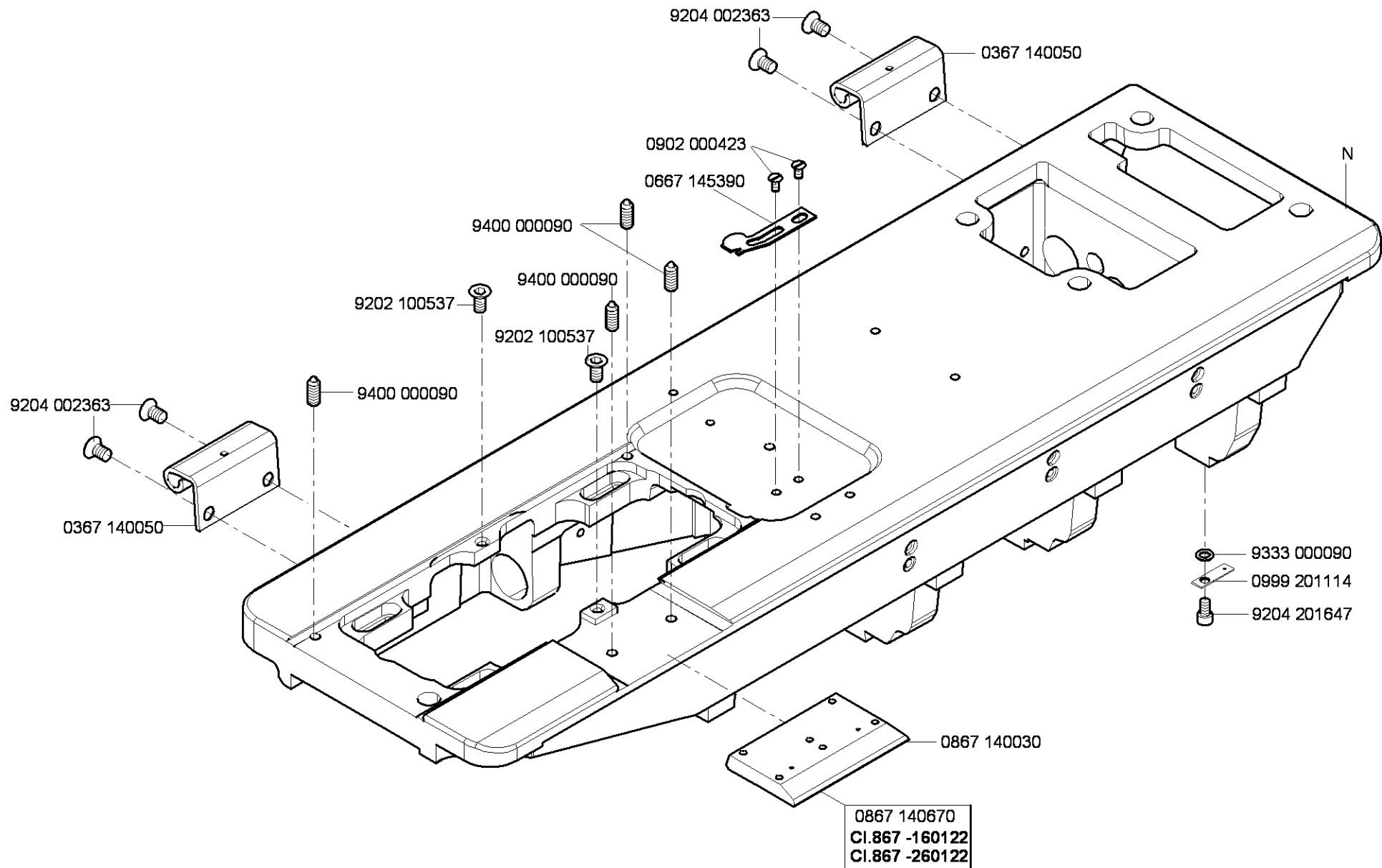

0867 140670
Cl.867 -160122
Cl.867 -260122

N - nicht als Einzelteil lieferbar
not available as separate part

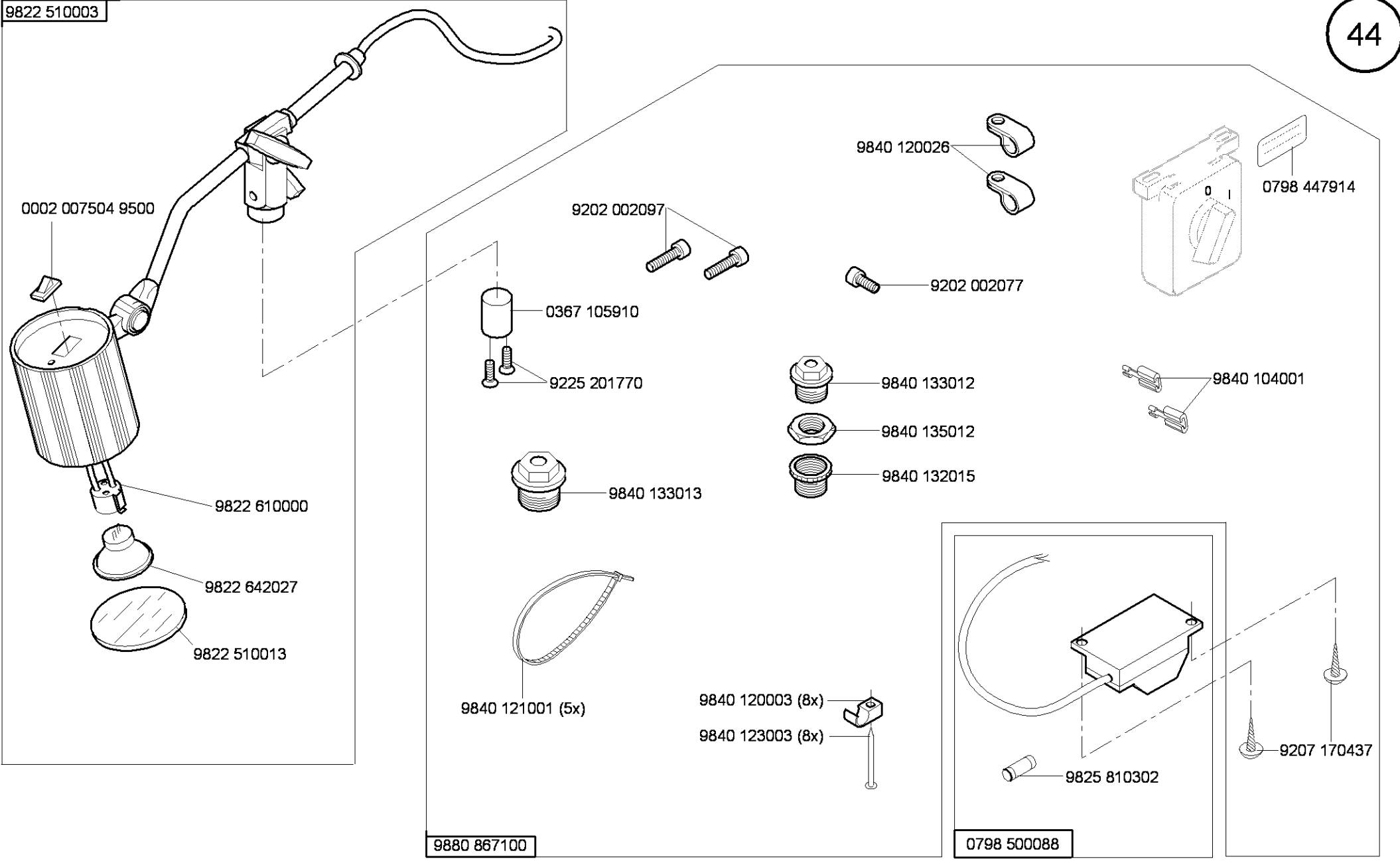

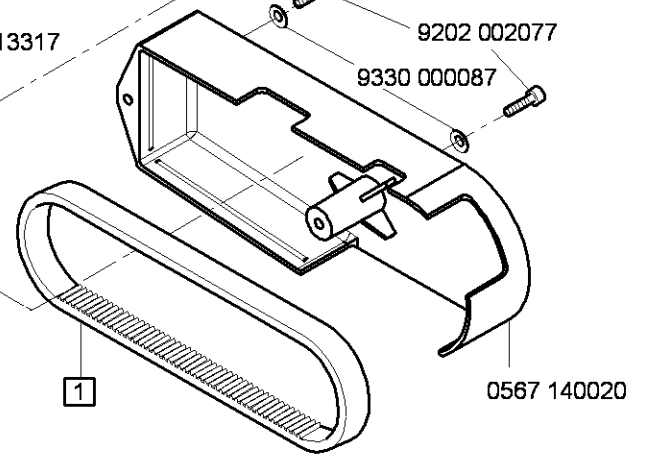
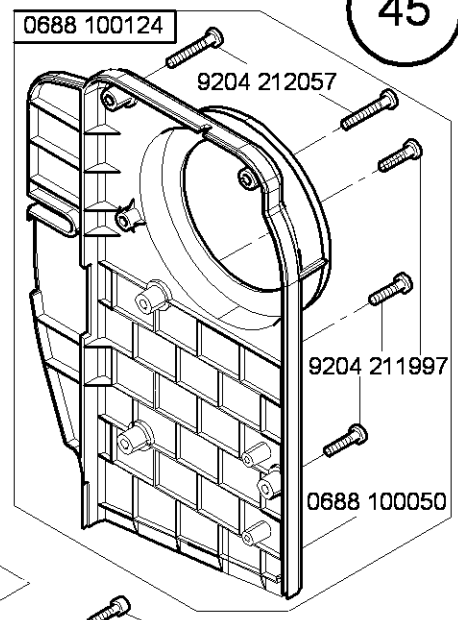
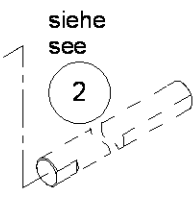
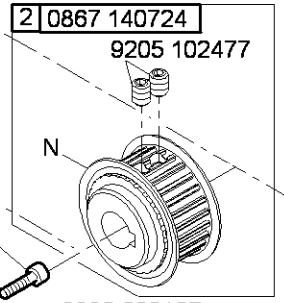
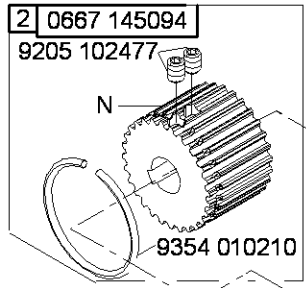
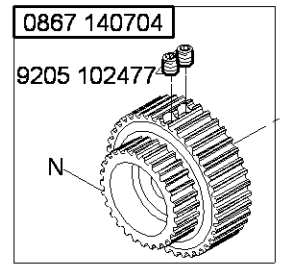
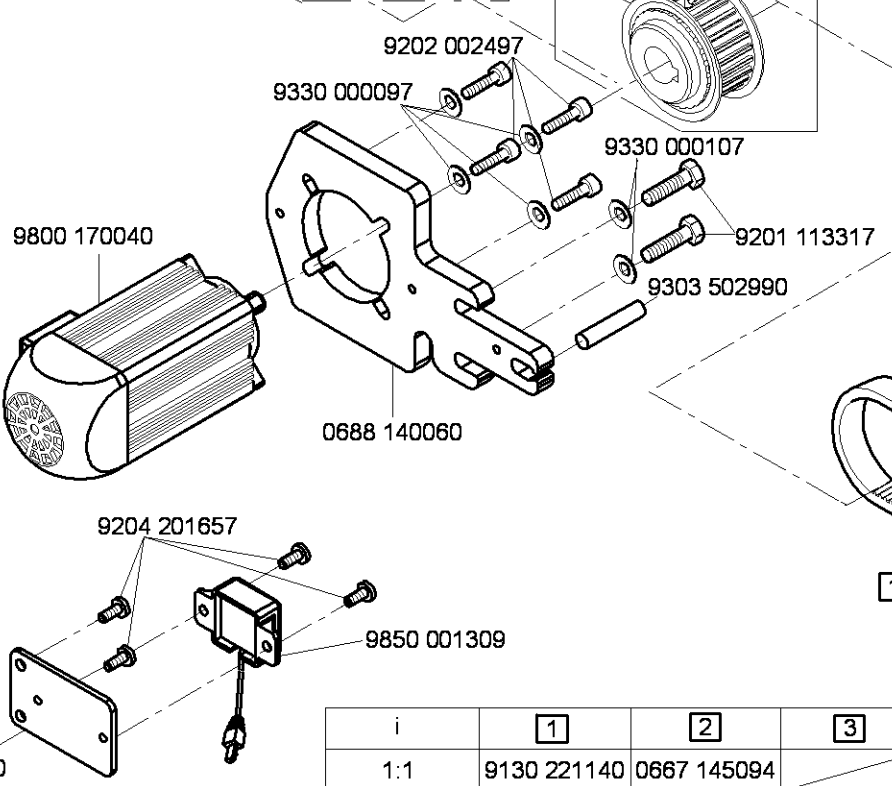
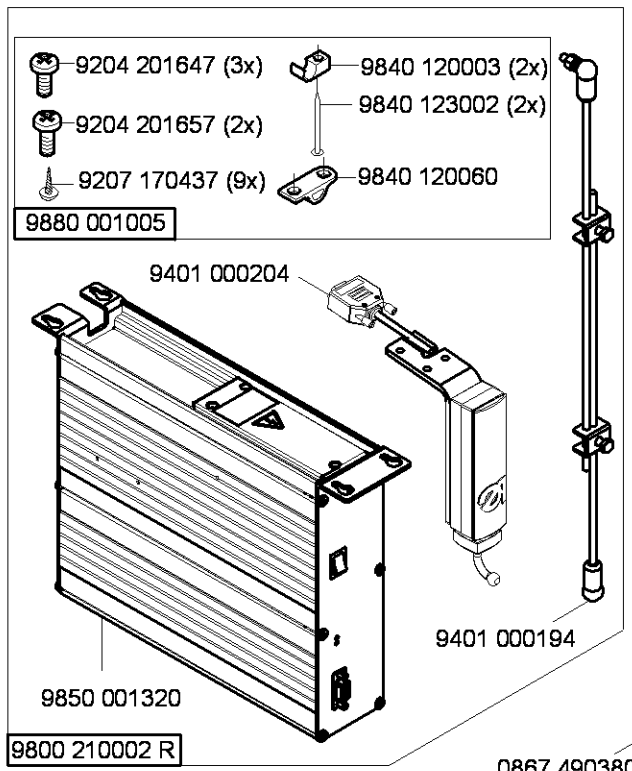
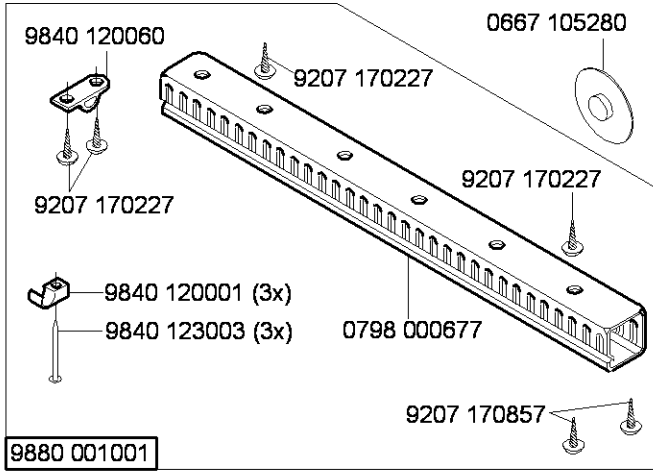

i	1	2	3	siehe/see ②
1:1	9130 221140	0667 145094		0667 145044
1:1,55	9130 221290	0867 140724	9800 327007	0867 140704

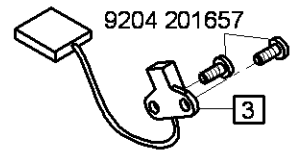

N - nicht als Einzelteil lieferbar
not available as separate part

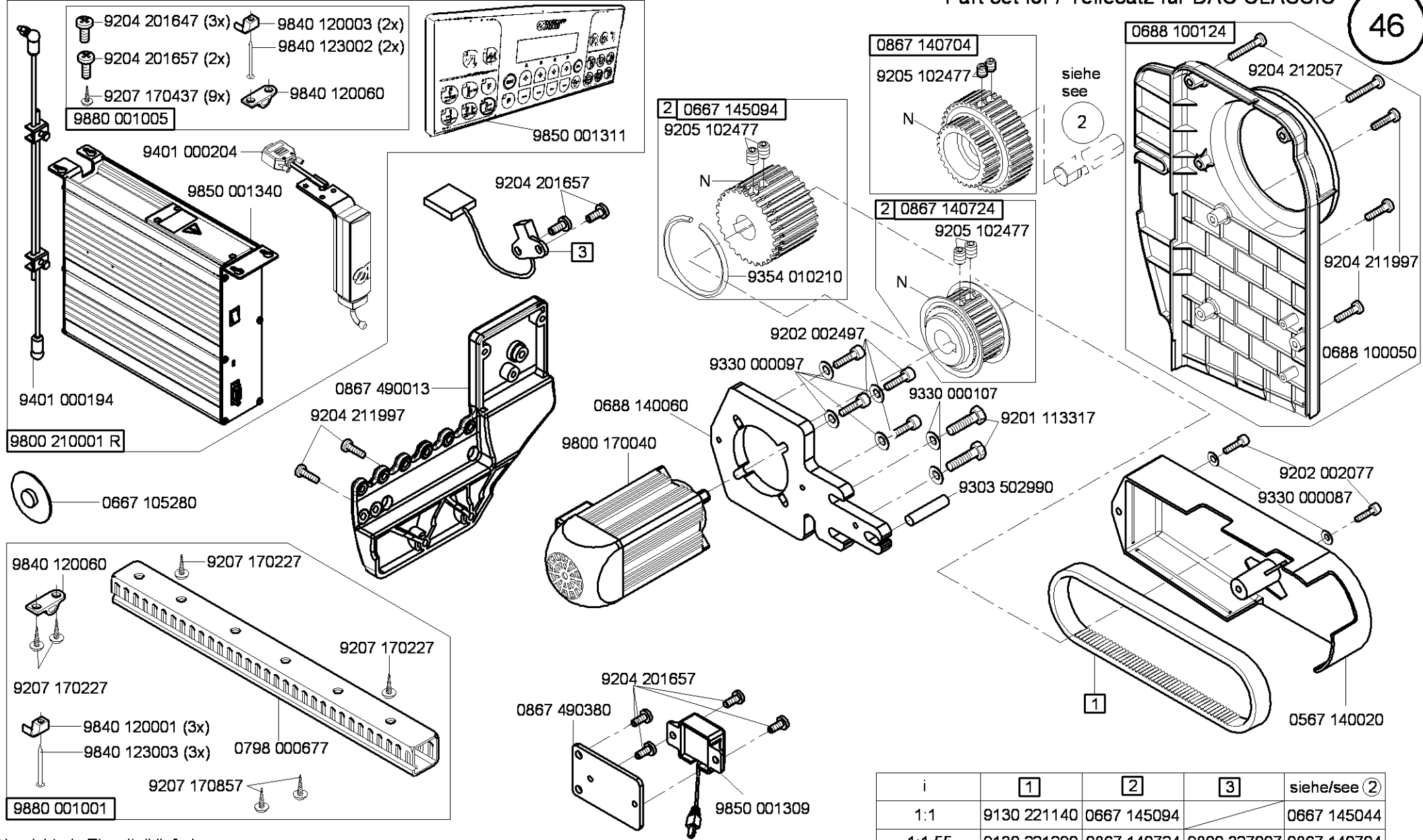

N - nicht als Einzelteil lieferbar
 not available as separate part

i	1	2	3	siehe/see ②
1:1	9130 221140	0667 145094		0667 145044
1:1,55	9130 221290	0867 140724	9800 327007	0867 140704

Part set for / Teilesatz für EFKA DC1550/DA321G

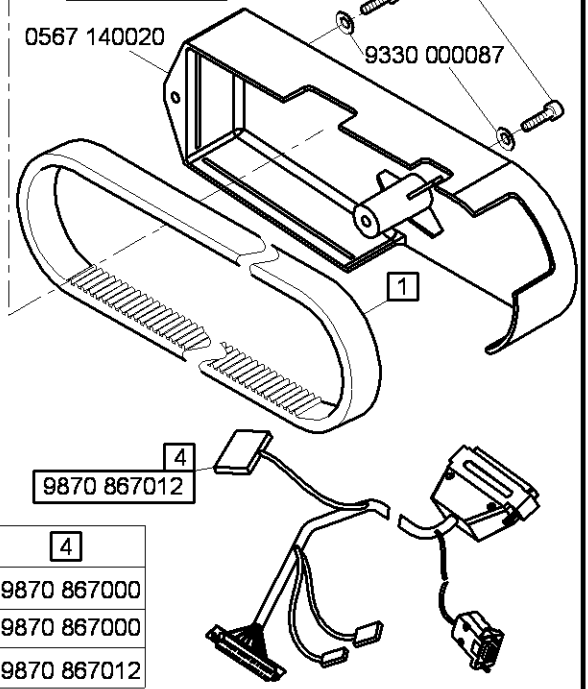
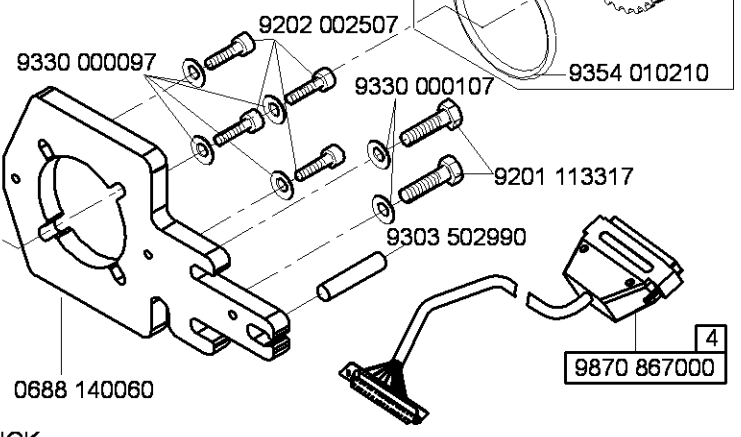
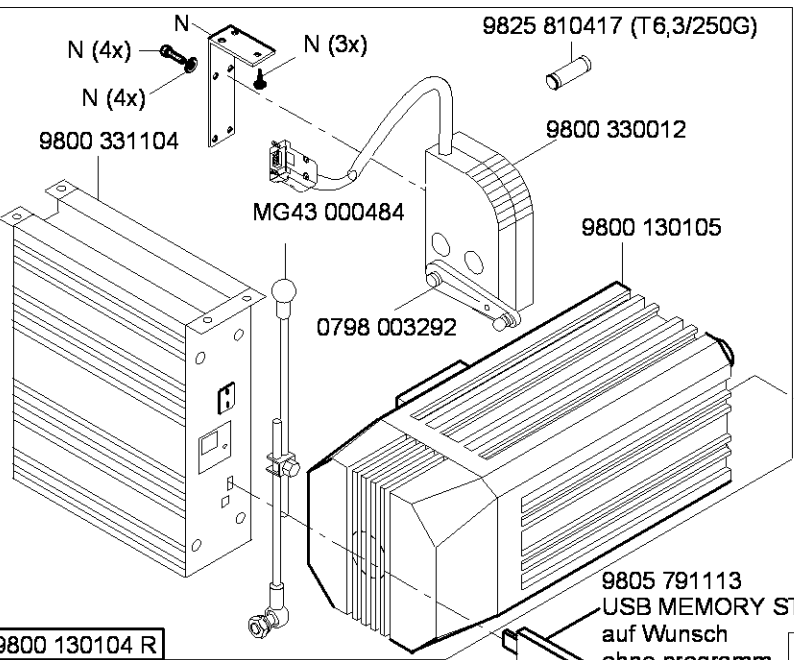
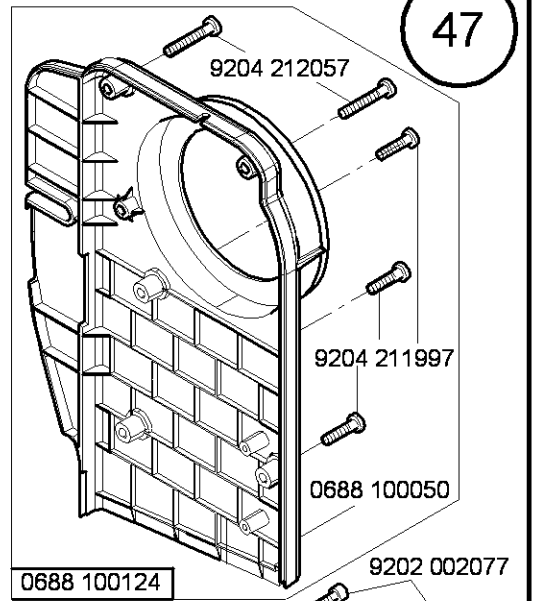
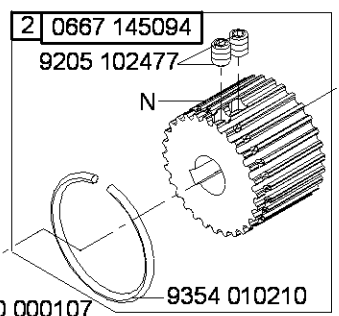
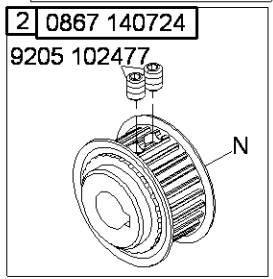
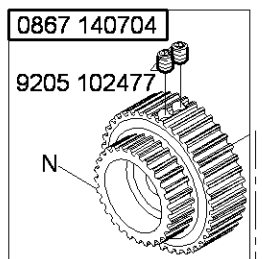
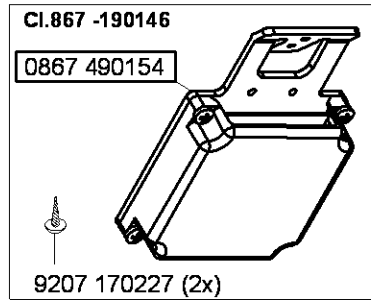
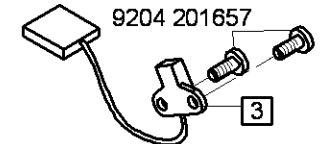
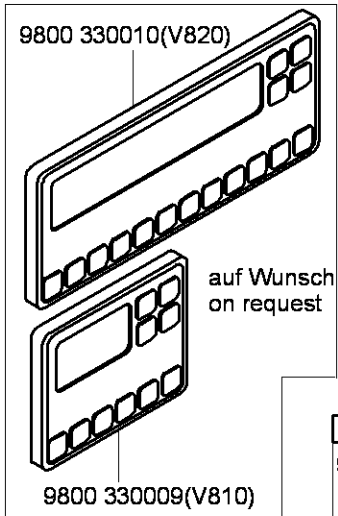
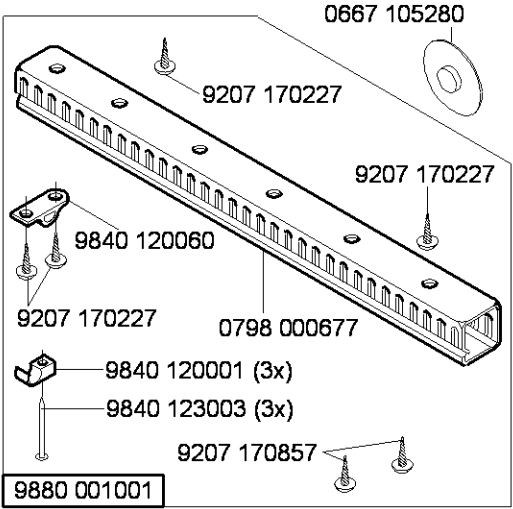

N - nicht als Einzelteil lieferbar
not available as separate part

i	1	2	siehe/see ②	3	4
1:1	9130 221140	0667 145094	0667 145044		9870 867000
1:1,55	9130 221290	0867 140724	0867 140704	9800 327005	9870 867000
1:1 (NSB)	9130 221140	0667 145094	0667 145044		9870 867012

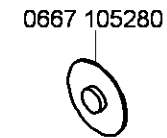
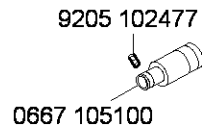
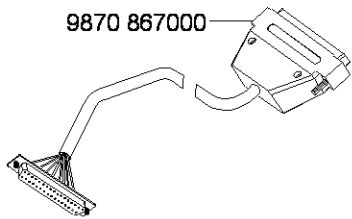
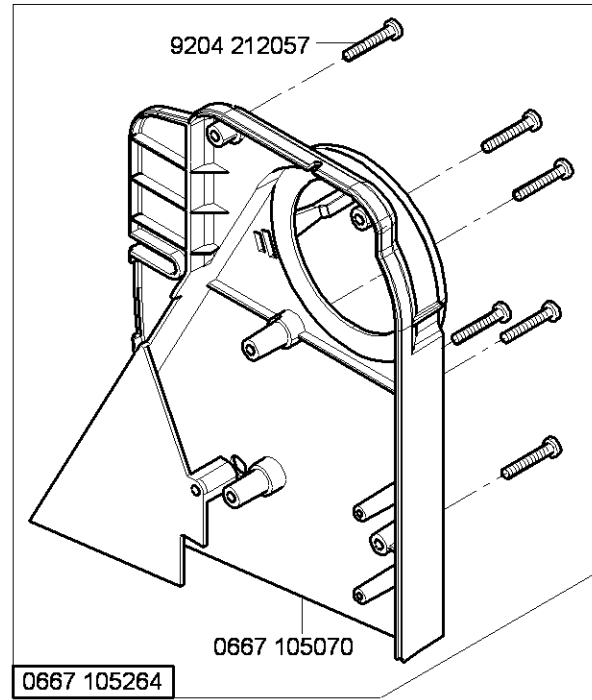
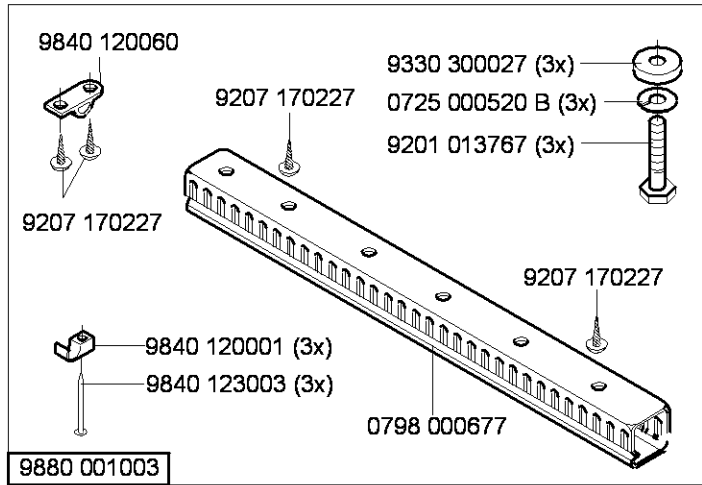

N - nicht als Einzelteil lieferbar
not available as separate part

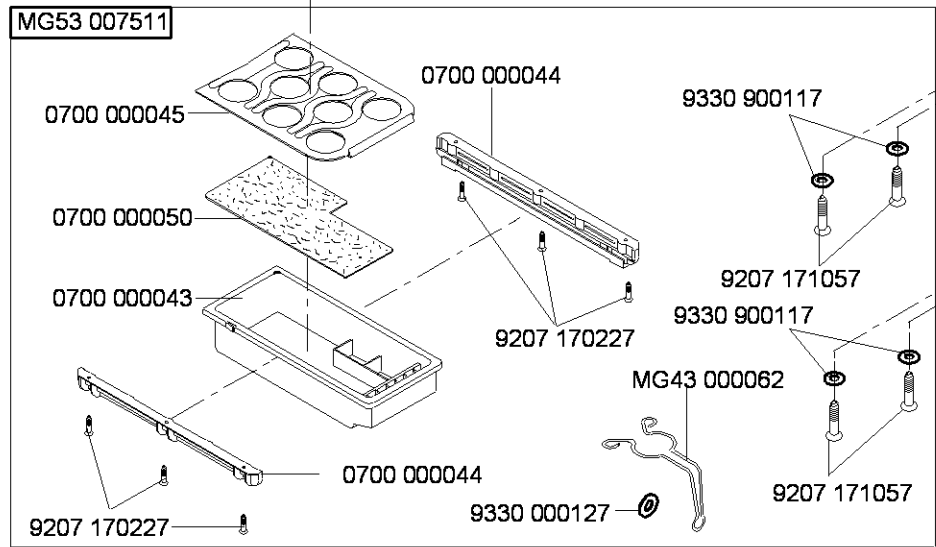
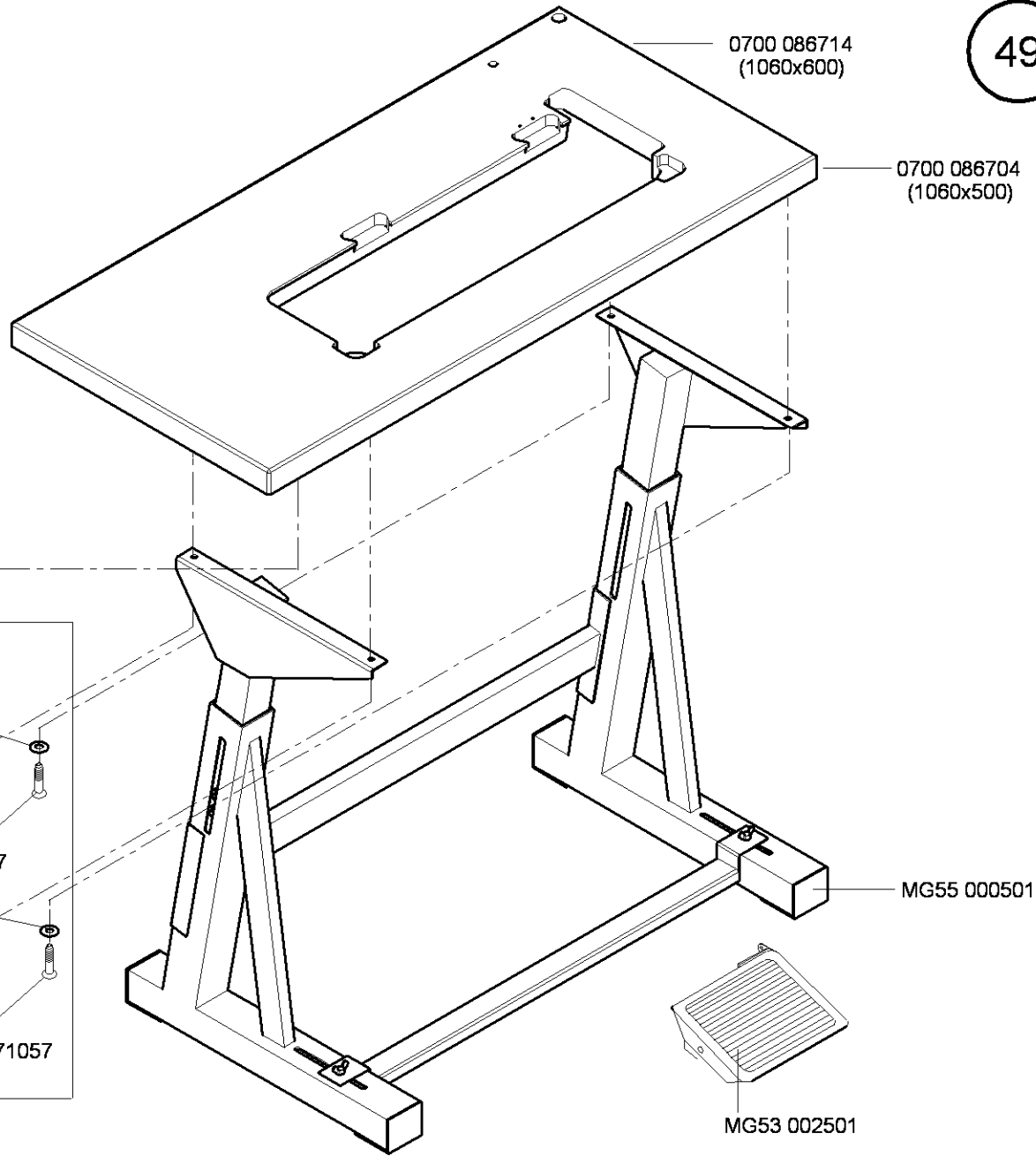

auf Wunsch
on request

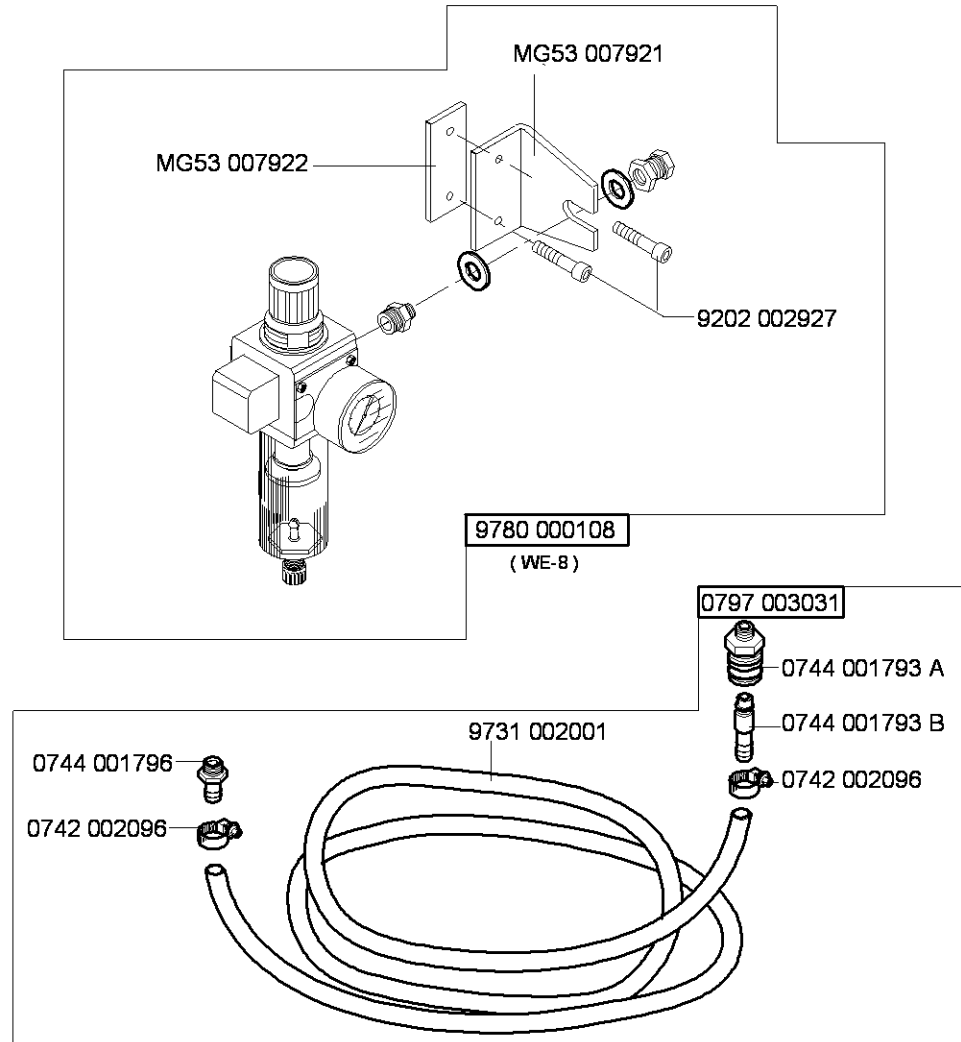

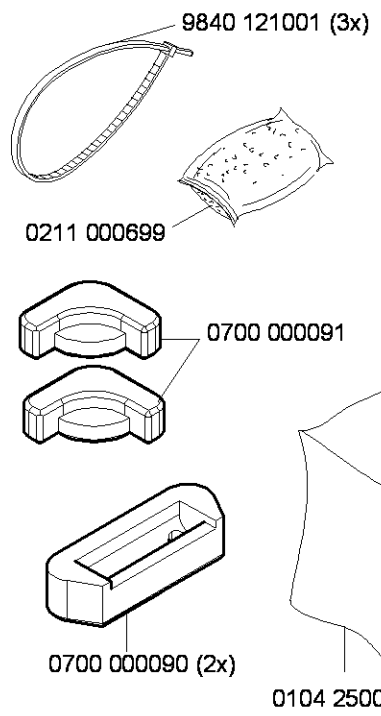
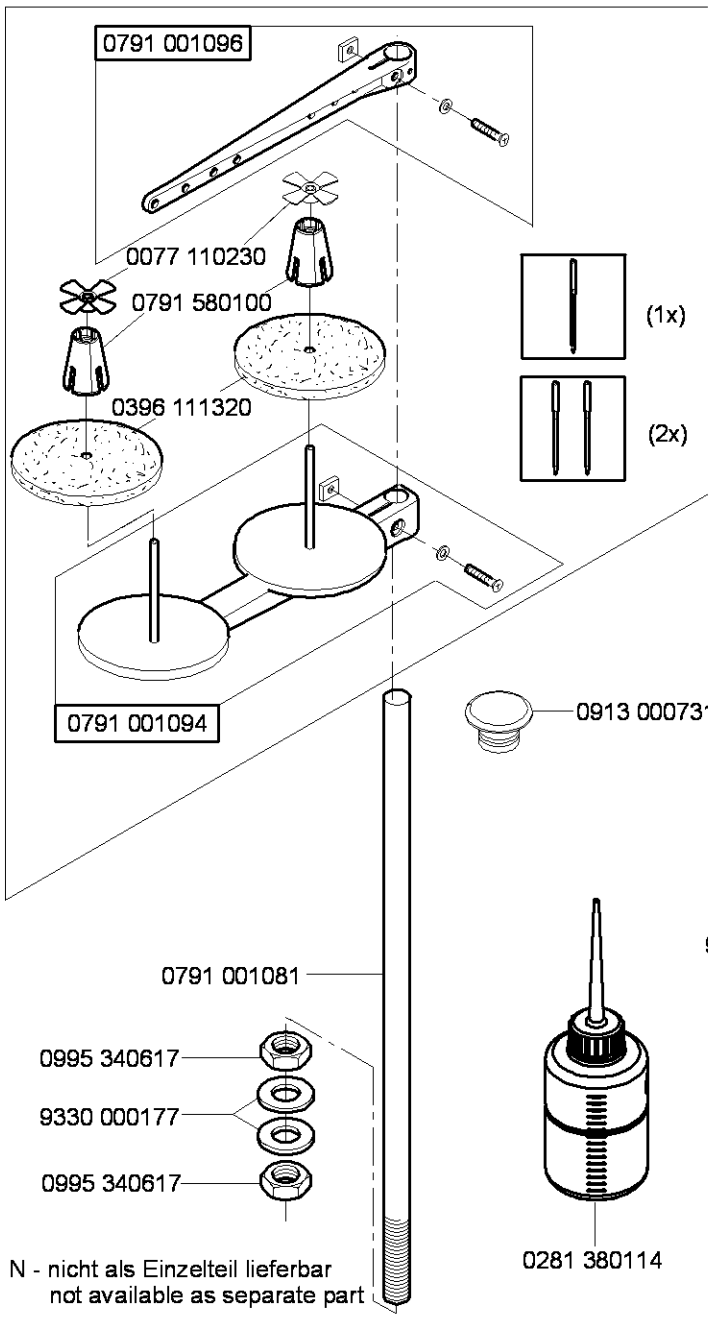

- CI.867 -190020
 - CI.867 -190040
 - CI.867 -190322
 - CI.867 -190342
 - CI.867 -290020
 - CI.867 -290040
 - CI.867 -290322
 - CI.867 -290342
- 9840 120030
- 9204 201698

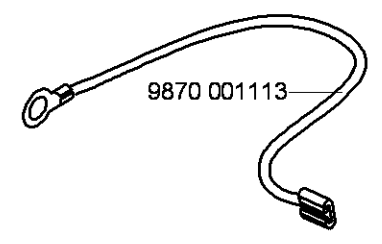
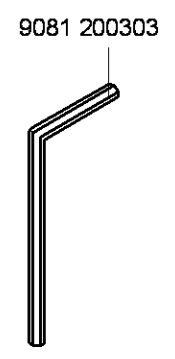
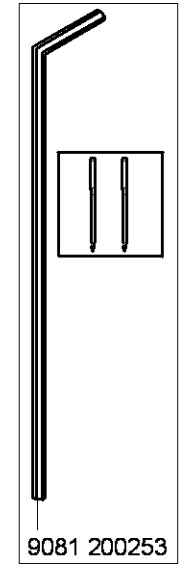
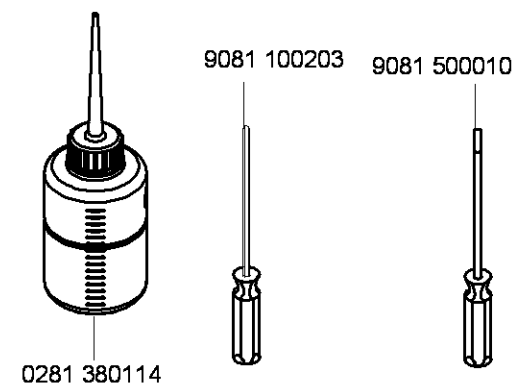
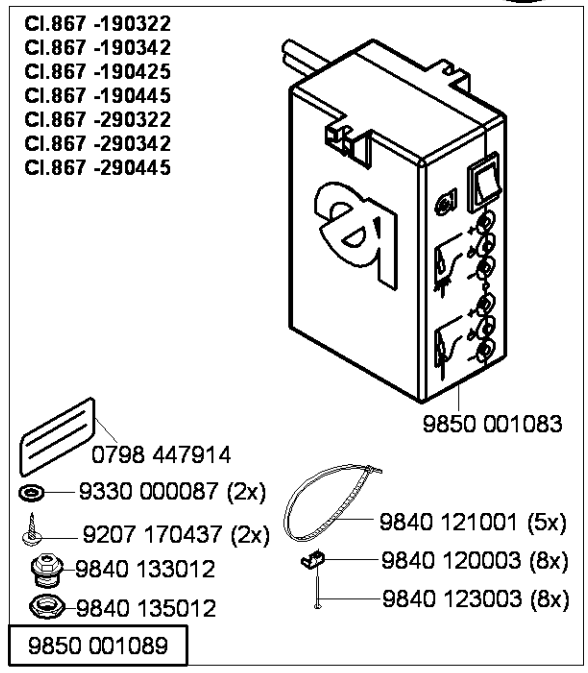

N - nicht als Einzelteil lieferbar
not available as separate part

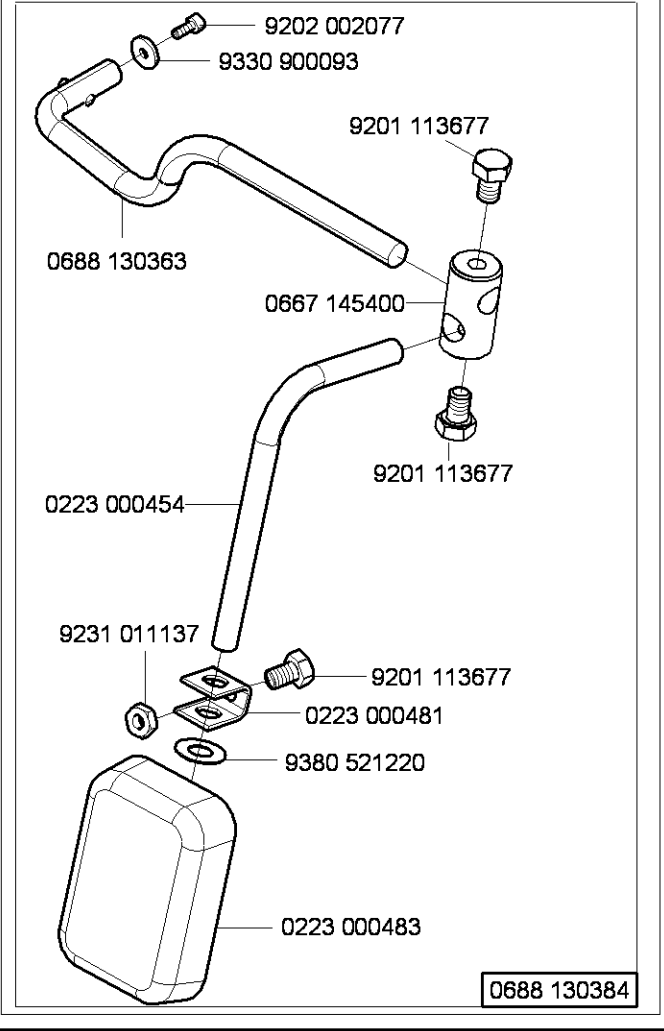
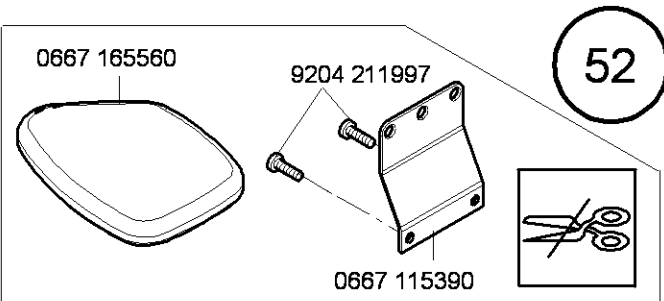
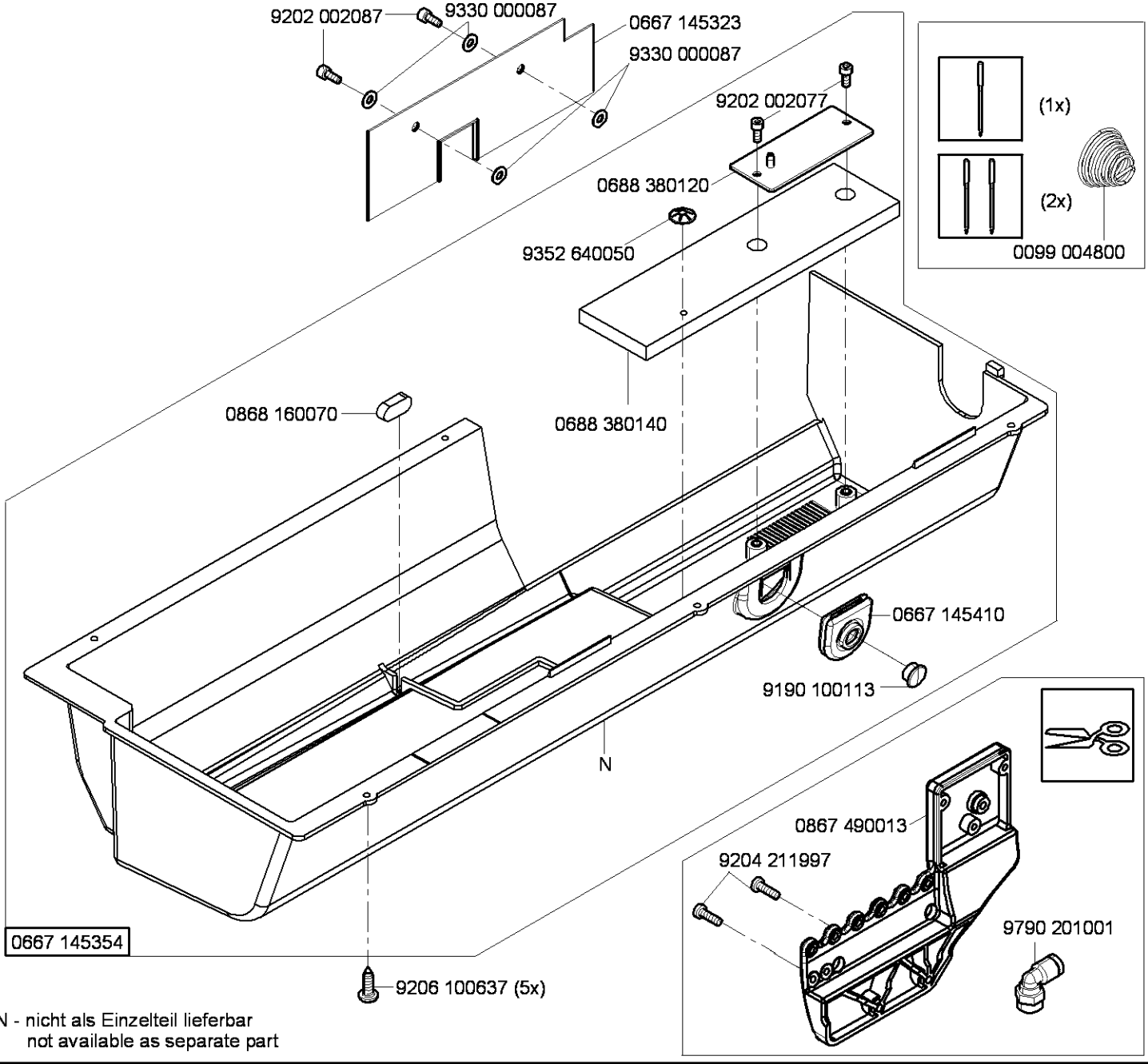

N - nicht als Einzelteil lieferbar
not available as separate part

0867 590104	0867 590124	0867 590114	0867 590134
0867 590184		0867 590164	0867 590174

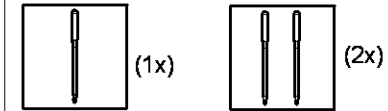

0767 150170	0767 150170	0667 150880	0667 150880
0667 155594		0667 155614	
	Cl.867 -190125		Cl.867 -190146
	Cl.867 -190425		

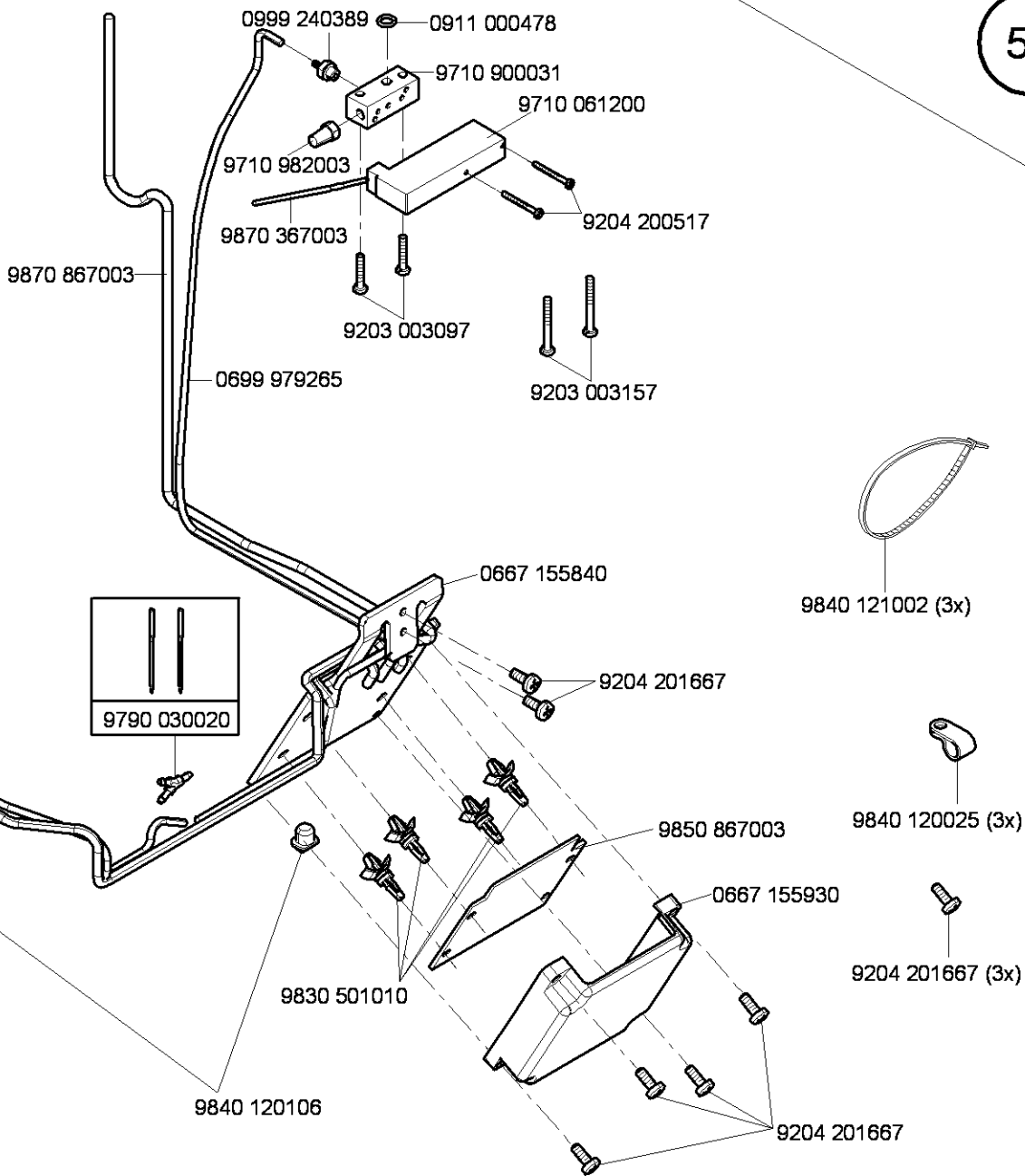
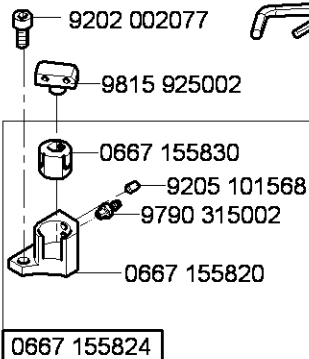
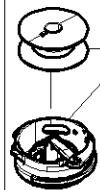

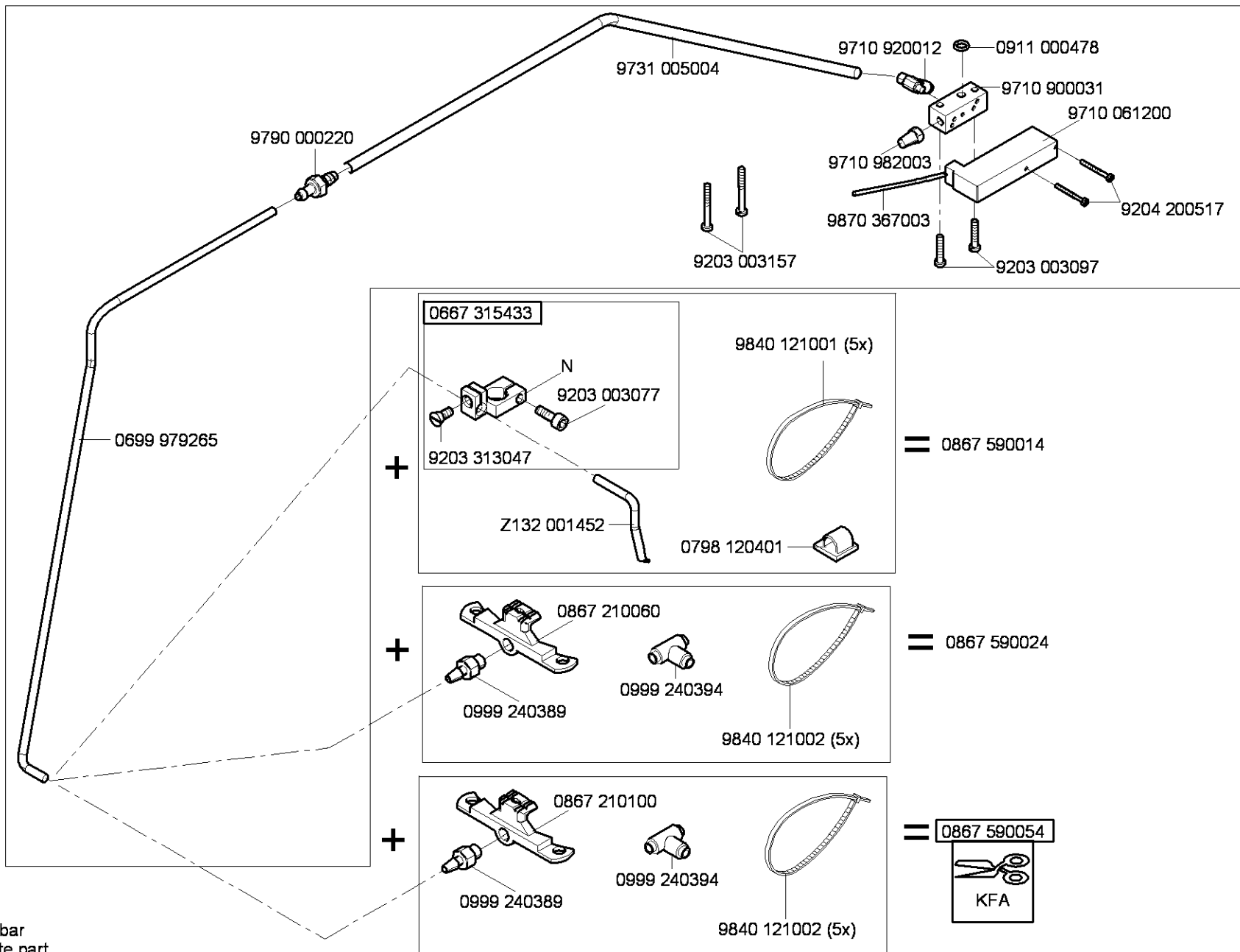

N - nicht als Einzelteil lieferbar
not available as separate part

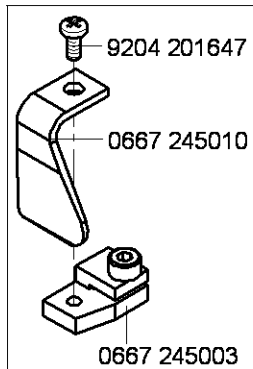

0667 245004

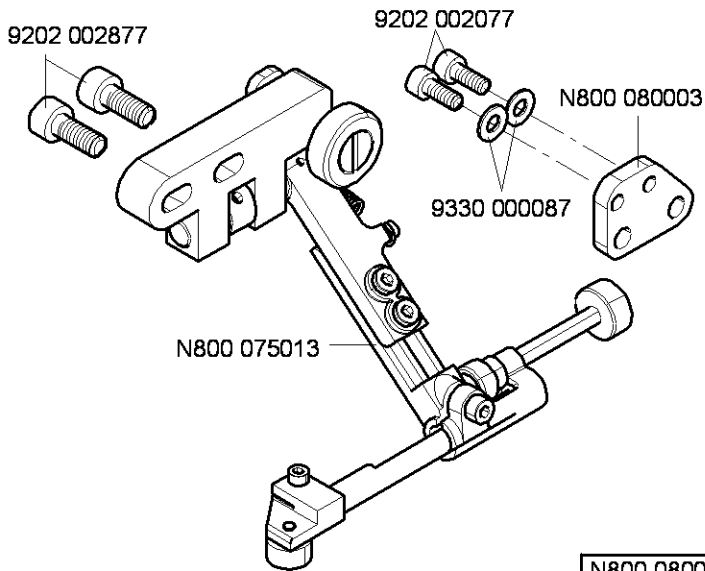

N800 080004

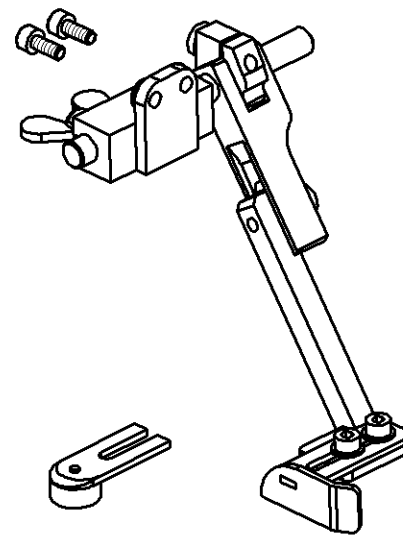

N800 080001

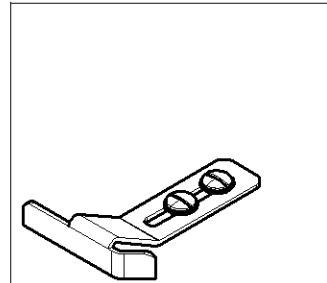

N800 080022

9880 867102

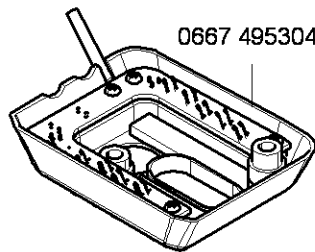

0667 495304

- 9840 120003 (8x)
- 9840 123003 (8x)
- 9840 121001 (5x)
- 9840 133013
- 9840 120026 (2x)
- 9840 133012
- 9202 002077 (3x)
- 9840 135012
- 9207 170437 (2x)
- 9840 132015
- 9840 104001 (2x)

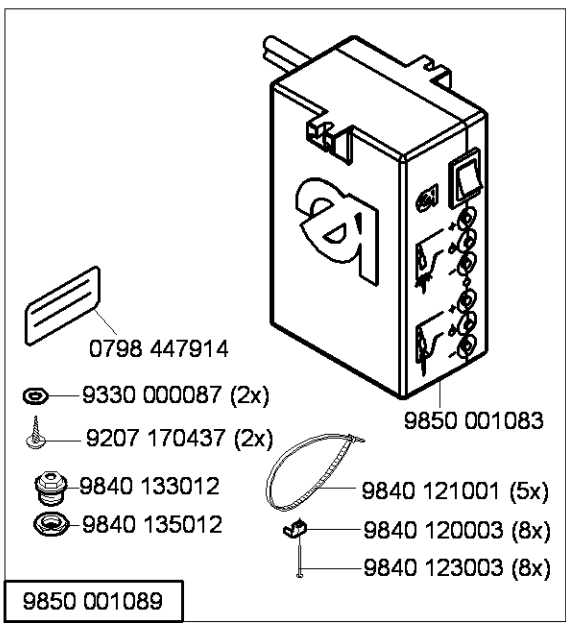

9850 001089

- 0798 447914
- 9330 000087 (2x)
- 9207 170437 (2x)
- 9840 133012
- 9840 135012
- 9850 001083
- 9840 121001 (5x)
- 9840 120003 (8x)
- 9840 123003 (8x)

N800 080021

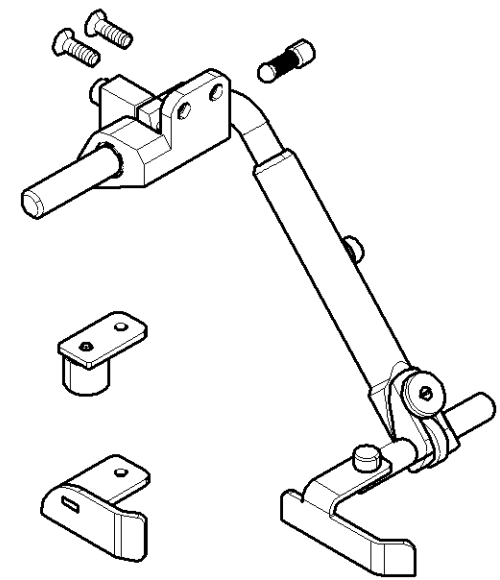

siehe Näherichtungen Blatt 1
see sewing equipment page 1
0867 590064

siehe Näherichtungen Blatt 1
see sewing equipment page 1
0867 590064

0667 105164

56

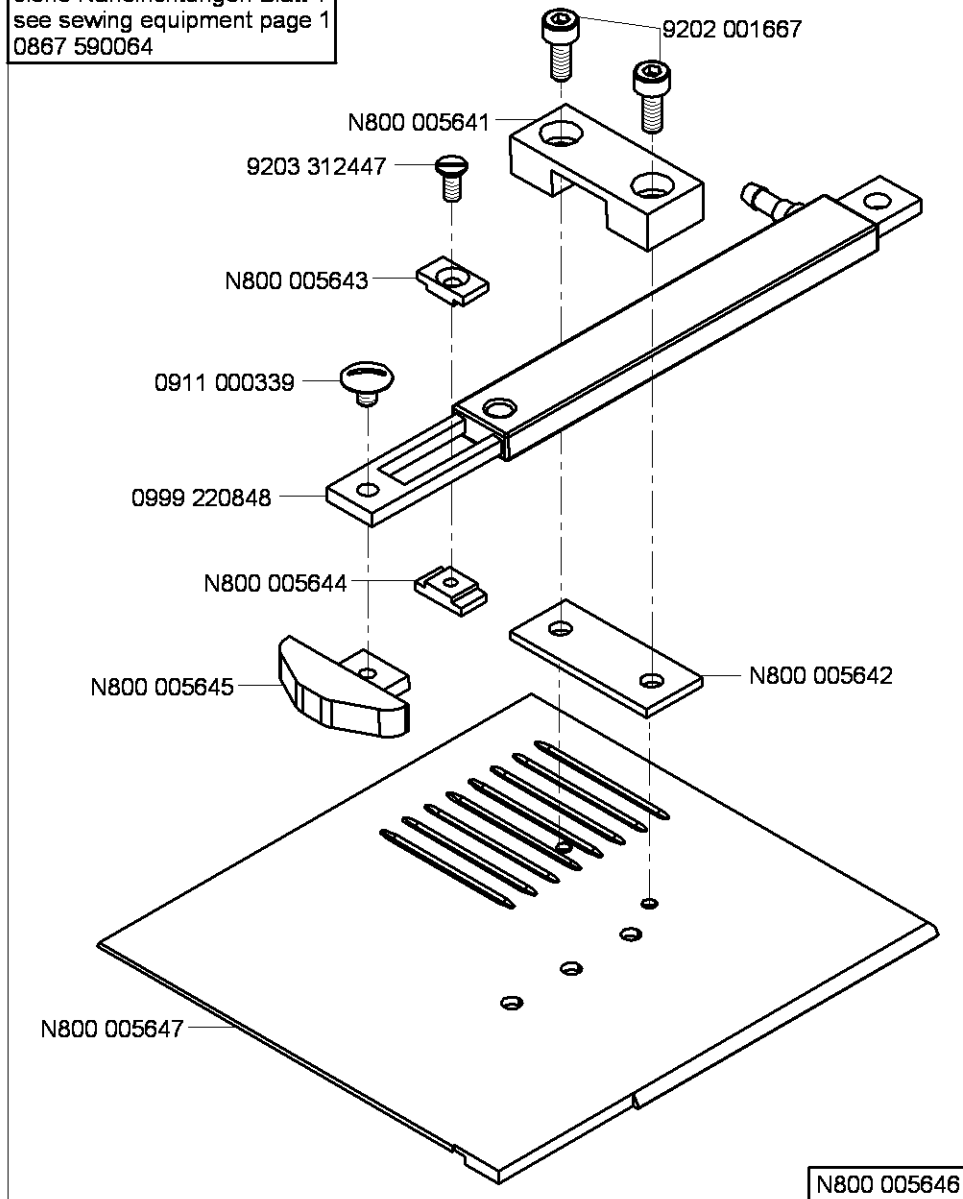

N800 005646

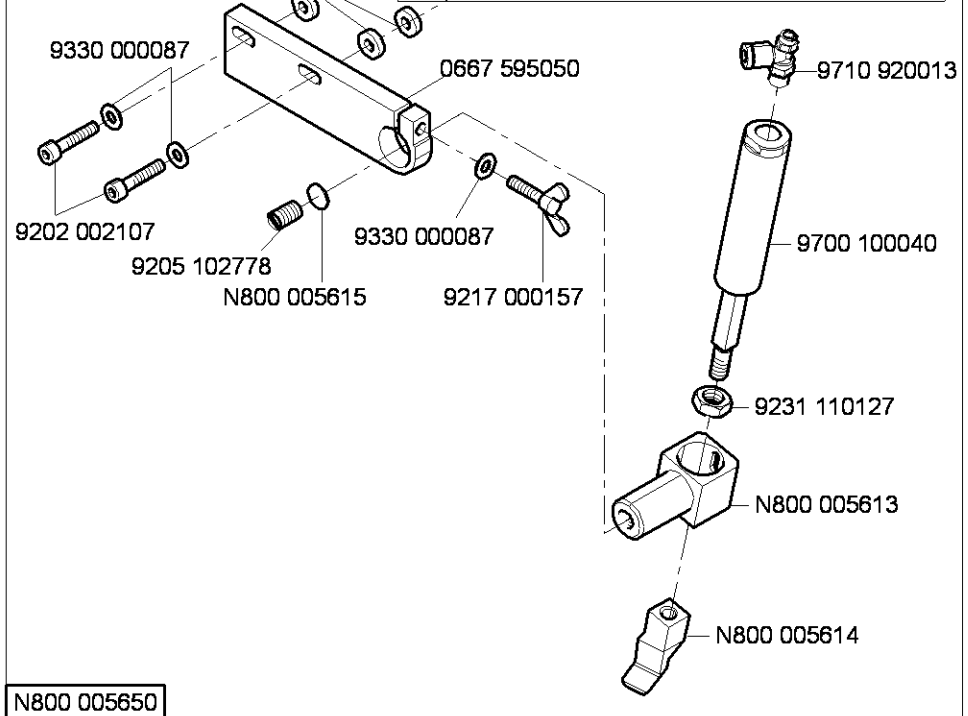
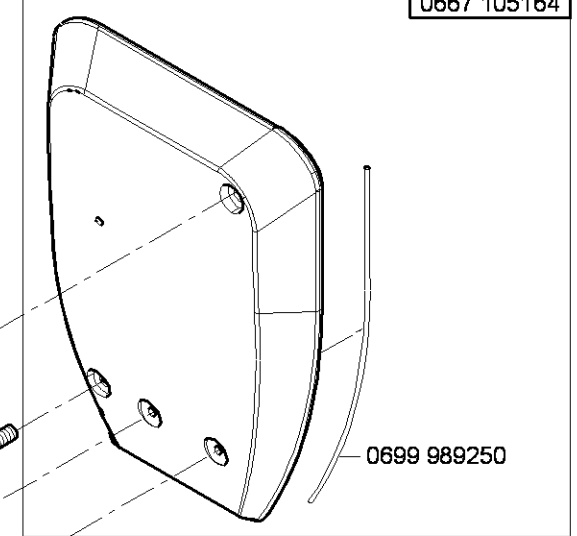

N800 005650

N - nicht als Einzelteil lieferbar
not available as separate part

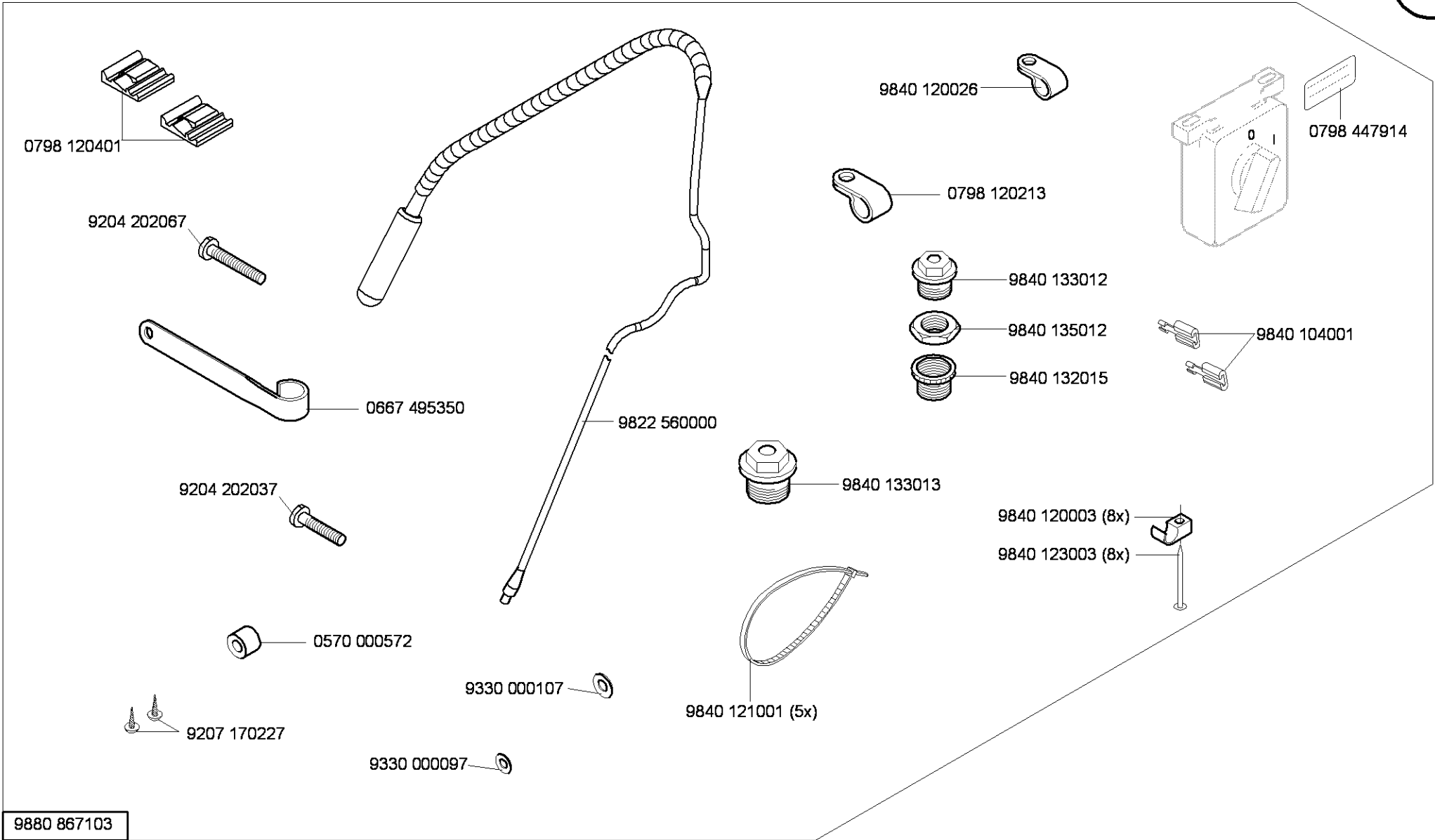

9880 867103

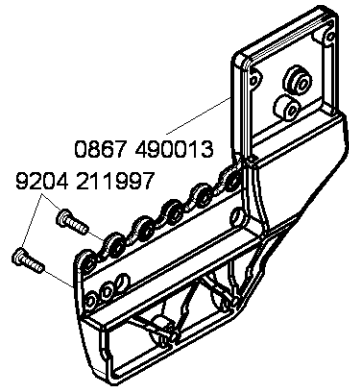
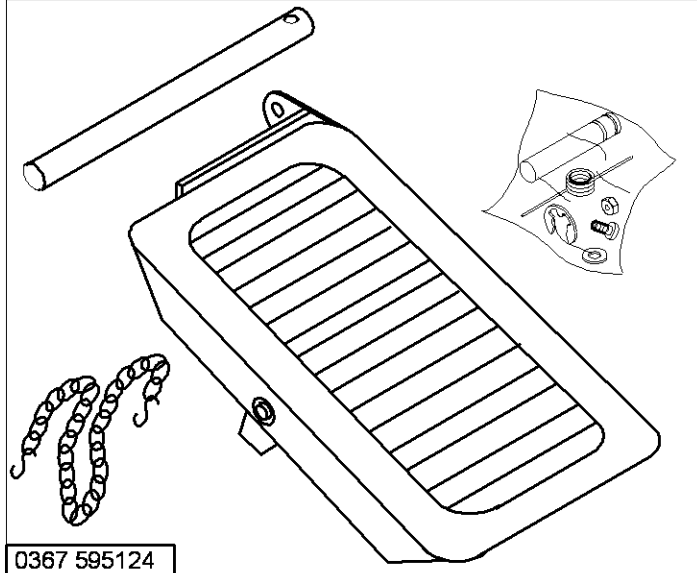
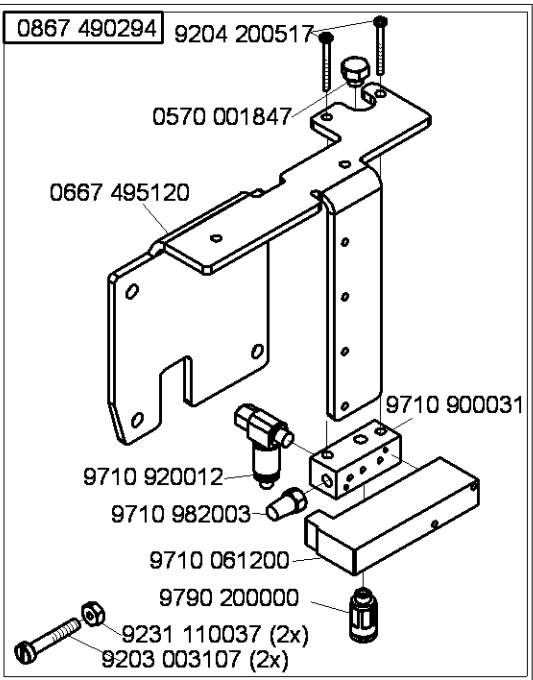
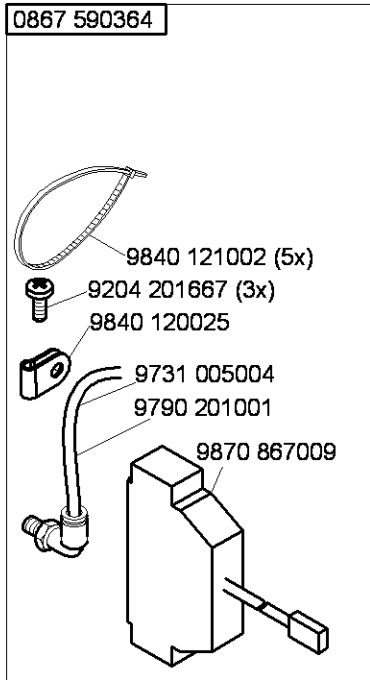
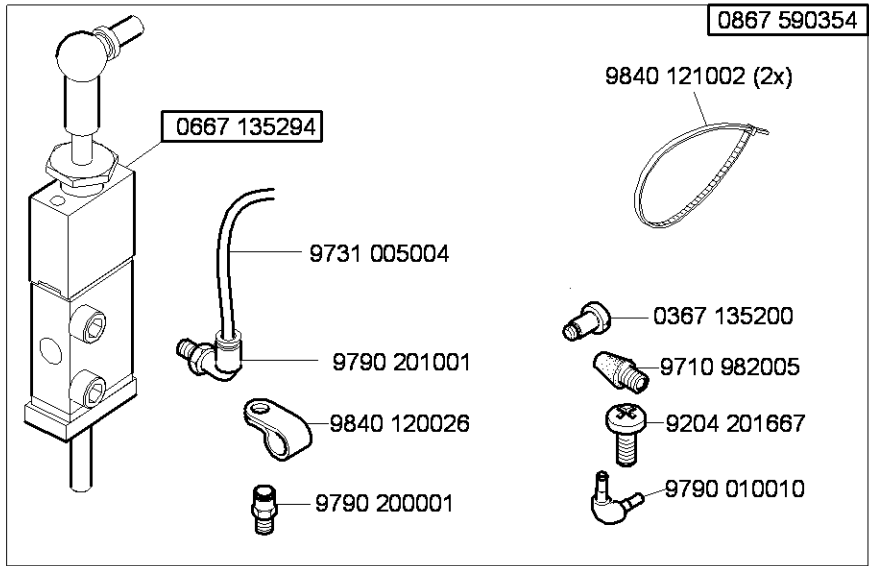
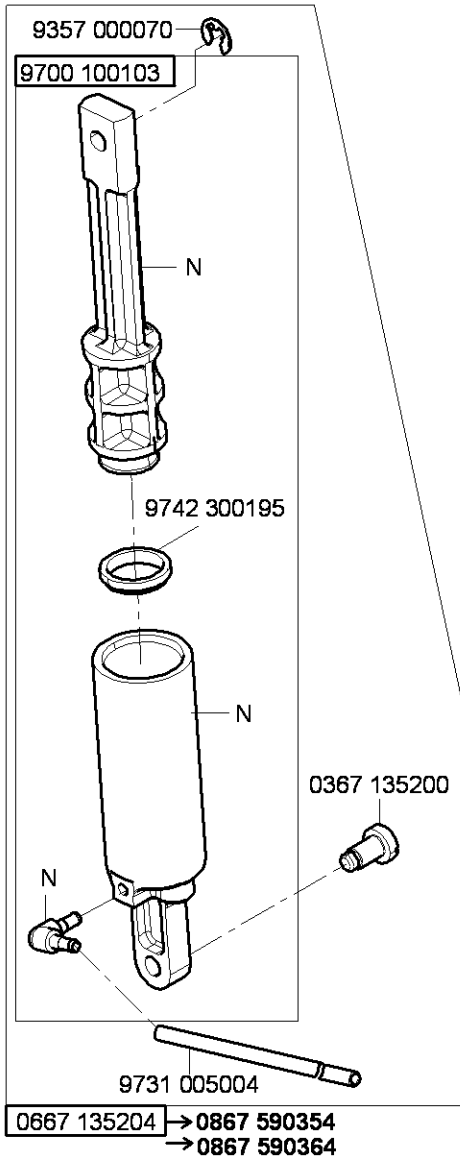
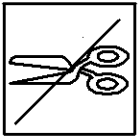

N - nicht als Einzelteil lieferbar
not available as separate part

- CI.867 -190020
- CI.867 -190040
- CI.867 -190122
- CI.867 -190125
- CI.867 -190142
- CI.867 -190145
- CI.867 -190146
- CI.867 -190322
- CI.867 -190342
- CI.867 -190425
- CI.867 -190445

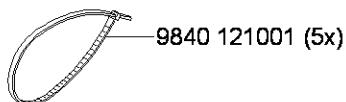
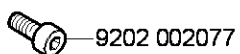
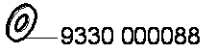
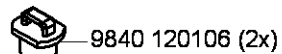
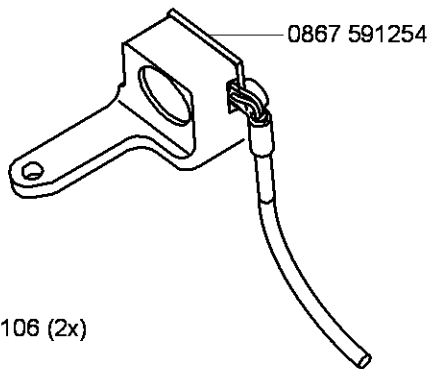

- 0867 591244 → 0867 591204
- 0867 591214
- 0867 591224
- 0867 591234

0867 591204

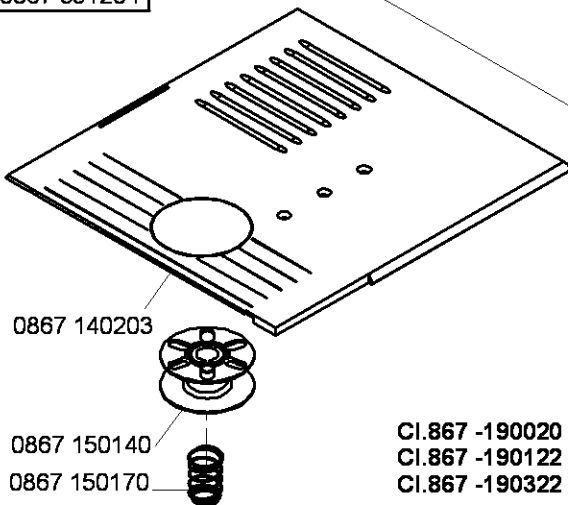

- CI.867 -190020
- CI.867 -190122
- CI.867 -190322

0867 591214

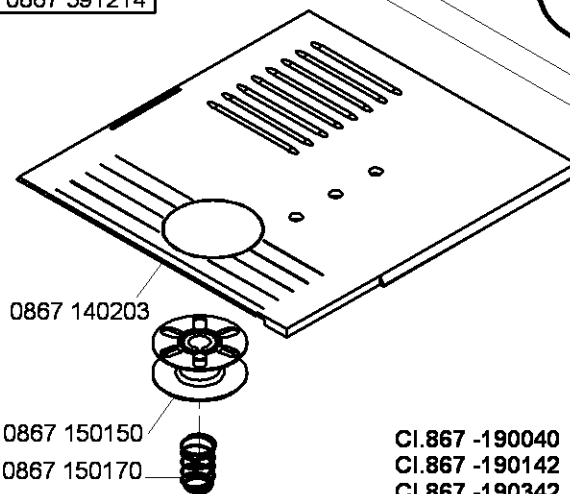

- CI.867 -190040
- CI.867 -190142
- CI.867 -190342

0867 591224

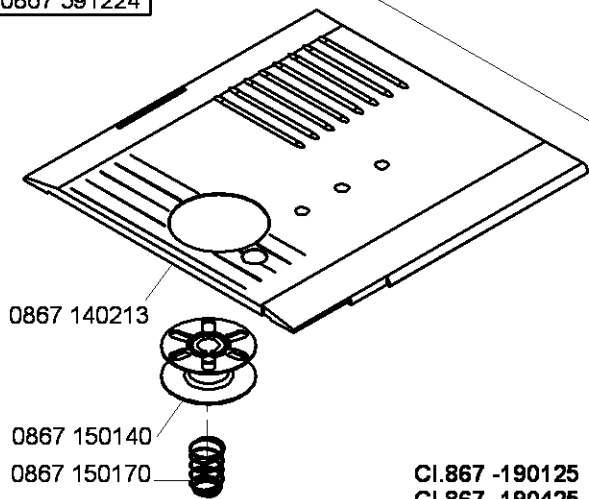

- CI.867 -190125
- CI.867 -190425

0867 591234

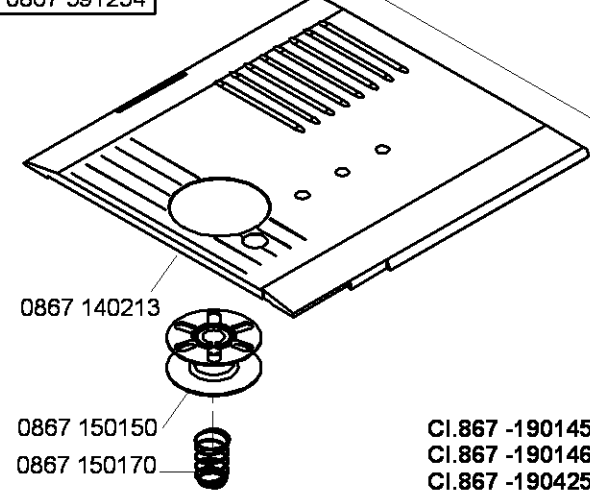

- CI.867 -190145
- CI.867 -190146
- CI.867 -190425
- CI.867 -190445

N - nicht als Einzelteil lieferbar
not available as separate part

0867 591004

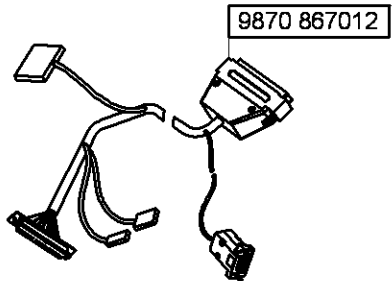

0867 490154

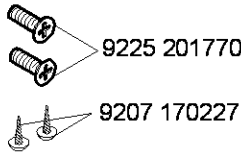
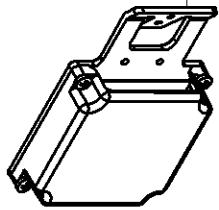

0867 591014

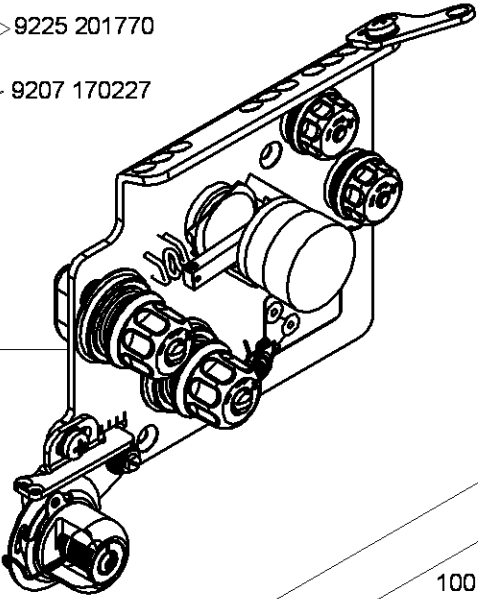

0667 105164

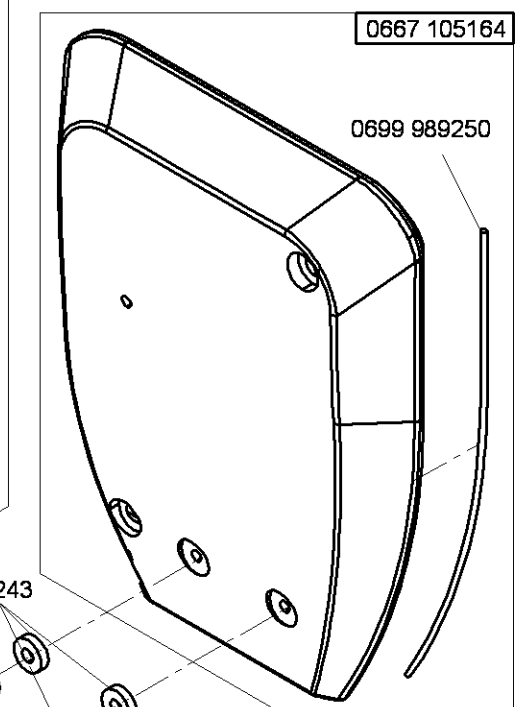

0699 989250

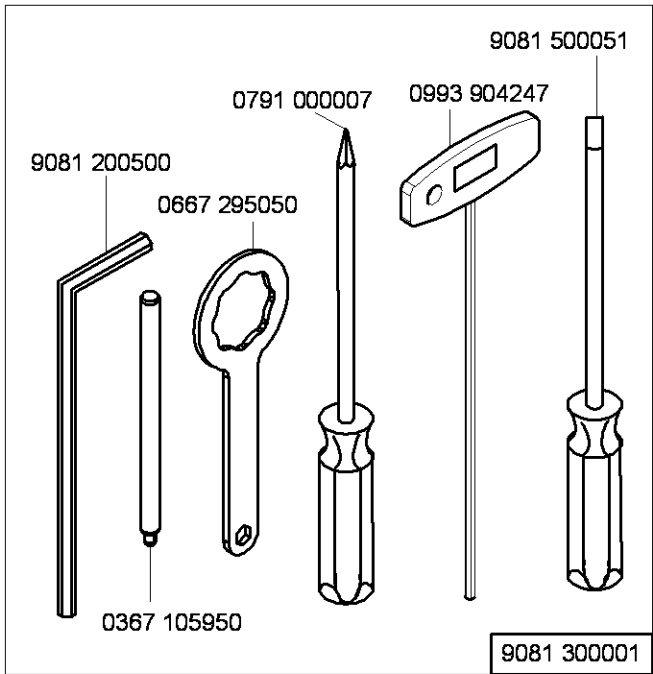

9081 300001

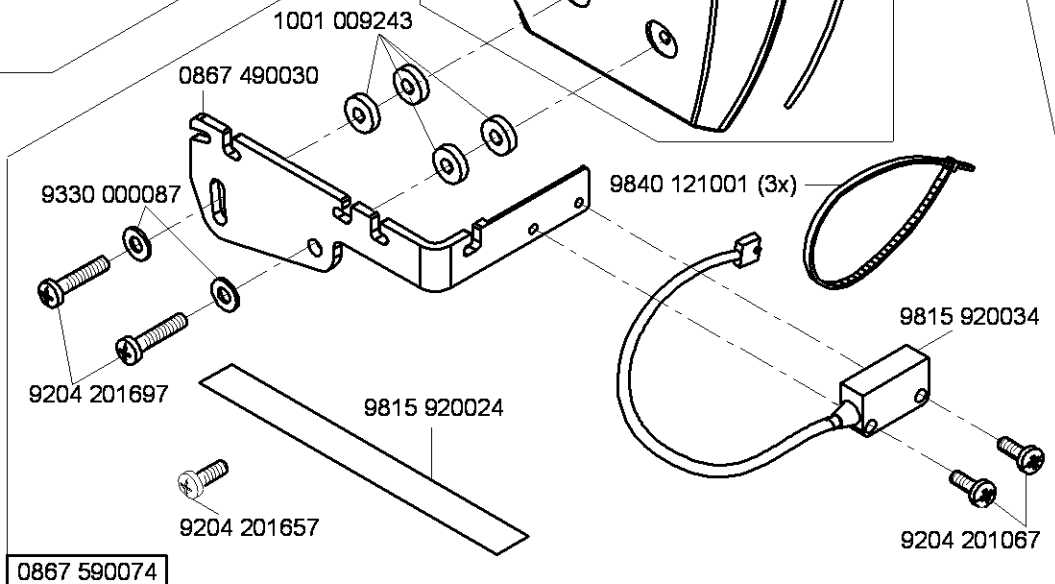

0867 590074

N - nicht als Einzelteil lieferbar
not available as separate part

0867 160024

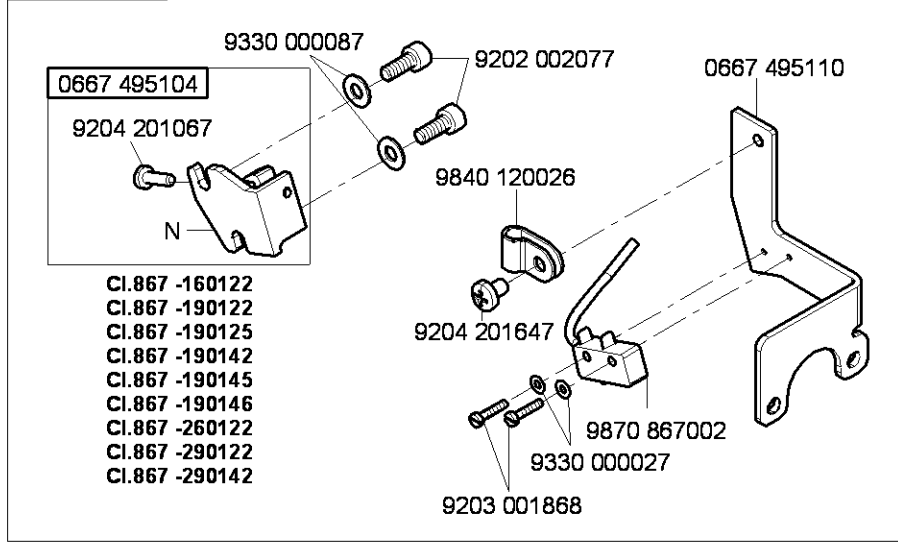

0867 590984

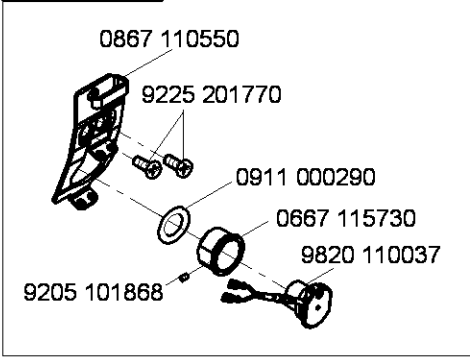

0667 595204

auf Wunsch
on request

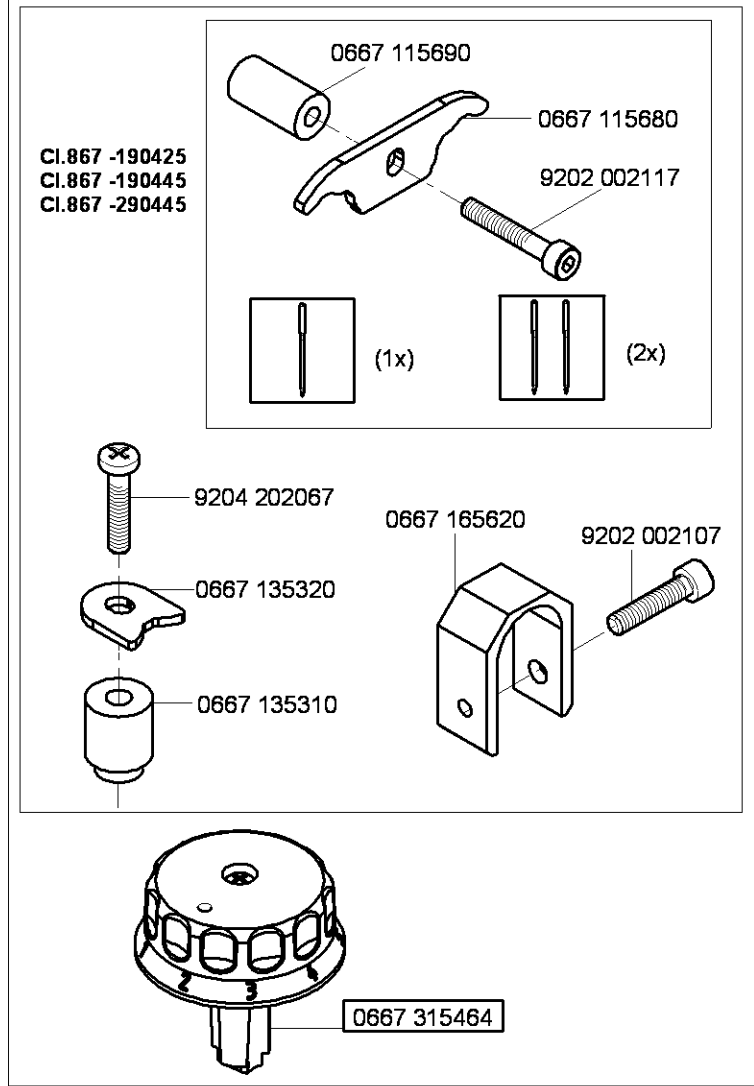

Teile-Nr./Part-No.	Tafel/Table	Teile-Nr./Part-No.	Tafel/Table	Teile-Nr./Part-No.	Tafel/Table	Teile-Nr./Part-No.	Tafel/Table	Teile-Nr./Part-No.	Tafel/Table
0002 007504 9500	44	0367 105083	6,7,8	0480 350200	21	0667 115080	24,28	0667 115514	24
0037 001280	24,25,26,27,28, 29,30	0367 105180	6,7,8	0480 350214	21	0667 115090	24,28	0667 115520	24,25,26,27,28, 29,30
0053 000350	24,28	0367 105910	44	0491 030652	7,33	0667 115094	28	0667 115530	24,25,26,27,28, 29,30
0061 001050	24,25,26,27,28, 29,30	0367 105950	60	0556 000821 A	31,32	0667 115110	28,30	0667 115570	28,29,30
0077 110230	51	0367 110340	24,25,26,27,28, 29,30	0558 000058 A	27	0667 115120	24,26,28,30	0667 115580	28,29,30
0099 004800	52	0367 110360	24,25,26,27,28, 29,30	0558 000059 A	27	0667 115130	24,28	0667 115590	24,25,26,27,28, 29,30
0099 004910	24,25,26,27,28, 29,30	0367 120100	3,4	0558 000061	27	0667 115134	24,28	0667 115600	24,25,26,27
0104 250010	51	0367 125020	6	0558 000061 B	27	0667 115140	24,28	0667 115610	24,25,26,27,28, 29,30
0211 000634	19,20	0367 125194	3	0567 140020	45,46,47	0667 115150	24,28	0667 115620	24,25,26,27
0211 000648	19,20	0367 135200	11,58	0570 000572	57	0667 115160	24,28	0667 115630	24,25,26,27,28, 29,30
0211 000699	51	0367 140050	43	0570 001847	34,35,36,37,58	0667 115170	24,25,26,27,28, 29,30	0667 115640	24,25,26,27,28, 29,30
0211 004516	3,4	0367 145110	9	0667 100050	3,4	0667 115180	24,25,26,27,30	0667 115680	61
0216 000591	23	0367 145180	6,7,8	0667 105023	40,41,42	0667 115203	24,25,26,27,28, 29,30	0667 115690	61
0216 000603	23	0367 150860	38	0667 105024	41	0667 115210	24,25,26,27,28, 29,30	0667 115730	39,61
0219 000321	39	0367 165120	6,7	0667 105040	1	0667 115220	29,30	0667 125033	3
0223 000454	52	0367 165140	7	0667 105053	1	0667 115224	29	0667 125060	5
0223 000481	52	0367 165970	12,33	0667 105060	39	0667 115250	24,25,26,27,28, 29,30	0667 125100	3,4
0223 000483	52	0367 315014	6	0667 105070	48	0667 115280	39	0667 125143	3
0244 000403	23	0367 315024	6	0667 105080	2	0667 115290	24,25,26,27,28, 29,30	0667 125150	3
0244 000700	6,7,8,9,23	0367 315130	6	0667 105093	2	0667 115320	3,4	0667 125160	3,4
0245 001660 A	14	0367 315223	6,7,8,9	0667 105100	48	0667 115354	25,26,27,28,29,30	0667 125243	3,4
0265 000911	24,28	0367 385133	3,4	0667 105120	39	0667 115360	24,28	0667 125254	3,4
0271 000275	23	0367 495010	39	0667 105144	39	0667 115390	52	0667 135013	9
0271 001639	31,32	0367 595124	58	0667 105164	56,60	0667 115420	24,28	0667 135033	9
0281 380114	51	0367 595124	58	0667 105190	40	0667 115430	24,28	0667 135040	10
0291 000159	3,4	0396 111320	51	0667 105254	40	0667 115440	25,26	0667 135073	10
0291 000334	31,32	0467 110220	24,25,26,27,28, 29,30	0667 105264	48	0667 115444	25	0667 135094	9
0291 000347	39	0467 150040	13,14	0667 105280	45,46,47,48	0667 115490	24,26		
0291 000537	38	0467 150120	13,14,15,18	0667 105294	42				
0291 000538	38	0467 150130	13,14,15	0667 105320	39				
		0467 150140	14,15,16,17,18	0667 110340	39				
		0467 150440	14,15,16,17,18	0667 115070	24,28				

Teile-Nr./Part-No.	Tafel/Table	Teile-Nr./Part-No.	Tafel/Table	Teile-Nr./Part-No.	Tafel/Table	Teile-Nr./Part-No.	Tafel/Table	Teile-Nr./Part-No.	Tafel/Table
0667 135103	9	0667 155450	20	0667 160170	31,32	0667 165620	61	0667 315300	40,41,42
0667 135124	9	0667 155460	19,20	0667 160350	31,32	0667 165700	33	0667 315314	6
0667 135150	10	0667 155474	19	0667 160374	31,32	0667 170070	23	0667 315320	6
0667 135190	6	0667 155484	20	0667 160480	6,7	0667 170120	23	0667 315330	6
0667 135194	6	0667 155490	19,20	0667 165063	7	0667 175010	23	0667 315354	41
0667 135204	11,58	0667 155530	19,20	0667 165130	6	0667 175020	23	0667 315364	40,41
0667 135294	58	0667 155540	19,20	0667 165133	7	0667 175030	23	0667 315423	8
0667 135310	61	0667 155550	19,20	0667 165134	7	0667 175034	23	0667 315433	54
0667 135320	61	0667 155594	14,53	0667 165154	7	0667 175040	23	0667 315454	42
0667 145044	2,45,46,47	0667 155604	14	0667 165164	7	0667 175053	23	0667 315464	42,61
0667 145074	2	0667 155614	16,53	0667 165190	33	0667 175060	23	0667 355103	21
0667 145094	45,46,47	0667 155634	16	0667 165210	33	0667 175083	23	0667 355110	21
0667 145264	2	0667 155660	14	0667 165220	33	0667 175104	23	0667 355123	21
0667 145303	2	0667 155720	20	0667 165234	31,32	0667 175114	23	0667 355130	21
0667 145323	52	0667 155820	53	0667 165243	31,32	0667 235010	3	0667 355140	21
0667 145354	52	0667 155824	53	0667 165250	31,32	0667 245003	55	0667 355150	22
0667 145390	43	0667 155830	53	0667 165260	31,32	0667 245004	55	0667 355173	21
0667 145400	52	0667 155840	53	0667 165273	31,32	0667 245010	55	0667 355240	38
0667 145410	52	0667 155893	19,20	0667 165284	31,32	0667 295050	60	0667 355260	22
0667 145464	2	0667 155900	19,20	0667 165290	31,32	0667 310563	6	0667 355270	22
0667 150830	16,17,18	0667 155930	53	0667 165304	31,32	0667 315053	6	0667 355283	22
0667 150840	16,17,18	0667 155940	2	0667 165354	32	0667 315113	6	0667 355300	22
0667 150850	16,17,18	0667 155950	19	0667 165370	7	0667 315164	6	0667 355310	22
0667 150860	16	0667 156034	17	0667 165390	8	0667 315174	12	0667 355324	22
0667 150870	16,17,18	0667 156044	17	0667 165403	8	0667 315203	5	0667 355343	22
0667 150880	53	0667 156130	14,15	0667 165423	8	0667 315213	5	0667 355344	22
0667 155100	19,20	0667 156180	16,17	0667 165454	8	0667 315223	5	0667 355363	22
0667 155114	19	0667 156190	13,14,15,18	0667 165500	8	0667 315243	5	0667 355410	22
0667 155390	19,20	0667 156210	16,17,18	0667 165550	7	0667 315253	5	0667 355420	21,22
0667 155403	19,20	0667 156320	13,14,15	0667 165560	52	0667 315273	6	0667 385013	6,7
0667 155424	19,20	0667 156330	16,17,18	0667 165570	33	0667 315280	6	0667 385033	38
0667 155440	19	0667 156440	16,17	0667 165580	7	0667 315294	6	0667 385070	39

Teile-Nr./Part-No.	Tafel/Table	Teile-Nr./Part-No.	Tafel/Table	Teile-Nr./Part-No.	Tafel/Table	Teile-Nr./Part-No.	Tafel/Table	Teile-Nr./Part-No.	Tafel/Table
0667 385143	38	0700 000045	49	0867 110364	26	0867 490013	46,52,58	0867 591214	59
0667 385174	38	0700 000050	49	0867 110384	30	0867 490030	60	0867 591224	59
0667 385180	39	0700 000090	51	0867 110550	39,61	0867 490154	47,60	0867 591234	59
0667 385220	38	0700 000091	51	0867 120654	4	0867 490294	58	0867 591244	59
0667 495093	34,35,36,37	0700 086704	49	0867 120660	4	0867 490380	45,46	0867 591254	59
0667 495104	32,61	0700 086714	49	0867 140030	43	0867 490400	34,35,36,37	0868 110054	28,29,30
0667 495110	32,61	0702 000073	27	0867 140203	59	0867 590014	54	0868 120113	4
0667 495120	58	0725 000520 B	48	0867 140213	59	0867 590024	54	0868 150400	15
0667 495133	34,35,36,37	0742 002096	50	0867 140670	43	0867 590054	54	0868 150414	15
0667 495290	34,35,36,37	0744 001155	25,26,27,29,30	0867 140704	45,46,47	0867 590074	60	0868 150434	15
0667 495304	39,55	0744 001793 A	50	0867 140724	45,46,47	0867 590104	53	0868 160070	52
0667 495350	57	0744 001793 B	50	0867 150140	13,59	0867 590114	53	0868 310080	6
0667 595050	56	0744 001796	50	0867 150150	59	0867 590124	53	0868 310084	6
0667 595204	61	0767 150170	53	0867 150170	13,59	0867 590134	53	0868 310090	6
0688 100050	45,46,47	0767 150590	14,15,16,17,18	0867 150204	18	0867 590164	53	0887 380010	38
0688 100124	45,46,47	0791 000007	60	0867 150214	18	0867 590174	53	0888 350124	21
0688 100173	1	0791 001081	51	0867 150323	19	0867 590184	53	0888 350134	21
0688 130260	10	0791 001094	51	0867 150333	20	0867 590354	58	0902 000423	43
0688 130280	9	0791 001096	51	0867 150343	19,20	0867 590364	58	0911 000290	39,61
0688 130290	9	0791 580100	51	0867 150804	13	0867 590464	33	0911 000339	56
0688 130363	52	0797 003031	50	0867 150814	13	0867 590984	61	0911 000478	34,35,37,53,54
0688 130384	52	0798 000677	45,46,47,48	0867 160024	61	0867 591004	60	0913 000731	51
0688 140060	45,46,47	0798 003292	47	0867 160620	6,7	0867 591010	27	0933 001544	38
0688 380040	38	0798 120213	57	0867 160630	6,7	0867 591014	27,60	0992 016580	13,14,15,16,17,18
0688 380120	52	0798 120401	54,57	0867 160640	6	0867 591020	27	0992 023560	13,14,15,16,17,18
0688 380130	38	0798 447914	44,51,55,57	0867 210060	54	0867 591030	27	0992 023577	13,14,15,16,17,18
0688 380140	52	0798 500088	44	0867 210100	54	0867 591040	27	0993 904247	60
0699 979104	19,20,37	0818 160210	7	0867 310073	6	0867 591050	27	0995 340617	51
0699 979265	53,54	0867 110034	26	0867 310233	6	0867 591060	27	0998 881010	19,20
0699 989250	39,40,41,42,56,60	0867 110064	30	0867 310430	6	0867 591080	27	0998 881610	6,33
0700 000043	49	0867 110250	24,25,26,27	0867 310440	6	0867 591090	27	0998 882510	24,26,28,30
0700 000044	49	0867 110260	28,29,30	0867 350083	22	0867 591204	59	0998 912080	3

Teile-Nr./Part-No.	Tafel/Table	Teile-Nr./Part-No.	Tafel/Table	Teile-Nr./Part-No.	Tafel/Table	Teile-Nr./Part-No.	Tafel/Table	Teile-Nr./Part-No.	Tafel/Table
9330 200107	21,22	9700 100100	32,33	9800 170040	45,46	9840 120001	45,46,47,48	9870 001113	51
9330 200110	19,20	9700 100103	11,58	9800 210001 R	46	9840 120003	12,39,44,45,46, 51,55,57	9870 367003	53,54
9330 300027	48	9710 061200	34,35,36,37,53, 54,58	9800 210002 R	45	9840 120025	12,53,58	9870 867000	47,48
9330 700107	40,41,42	9710 900011	34,37	9800 327005	47	9840 120026	32,38,39,44,55, 57,58,61	9870 867001	21,22
9330 900093	52	9710 900031	53,54,58	9800 327007	45,46	9840 120030	51	9870 867002	32,61
9330 900117	49	9710 900047	34,35,37	9800 330012	47	9840 120060	45,46,47,48	9870 867003	53
9332 500137	24,26,28,30	9710 900073	36	9800 331104	47	9840 120104	21,22,38	9870 867009	58
9333 000090	43	9710 920012	34,35,36,37,54,58	9815 301079	34,35,36,37	9840 120105	33,38	9870 867012	47,60
9334 000051	19,20	9710 920013	56	9815 301081	34,35	9840 120106	53,59	9880 001001	45,46,47
9334 001630	3,4,6,7,10,23, 31,32	9710 982003	36,53,54,58	9815 301090	34,35,36,37	9840 121001	12,39,44,51,54, 55,57,59,60	9880 001003	48
9334 001640	5,8	9710 982006	34,35,37	9815 301091	34,35,36,37	9840 121002	53,54,58	9880 001005	45,46
9352 640050	52	9731 001035	38	9815 301096	34,35	9840 123002	45,46	9880 867100	44
9353 000087	19,20	9731 002001	50	9815 310008	34,35,36,37	9840 123003	12,39,44,45,46, 47,48,51,55,57	9880 867101	34,35
9353 000350	2	9731 005004	11,12,25,26,27, 29,30,32,33,34, 35,36,37,54,58	9815 310009	34,35,36,37	9840 130007	38	9880 867102	39,55
9353 000420	2	9731 007035	3,4	9815 920024	60	9840 130008	38	9880 867103	57
9353 000470	1,2	9740 000607	40,41,42	9815 920034	60	9840 132015	39,44,55,57	9880 867104	12
9354 010210	2,45,46,47	9742 300190	12	9815 925002	53	9840 133012	39,44,51,55,57	9880 867105	12
9354 400800	19,20,38	9742 300195	11,58	9820 110016	21,22	9840 133013	39,44,55,57	9880 867110	36,37
9357 000050	21,22	9780 000108	50	9820 110031	27	9840 135012	39,44,51,55,57	MG43 000062	49
9357 000070	6,7,10,11,12,19, 20,23,31,32,58	9790 000220	54	9820 110033	27	9850 001083	51,55	MG43 000484	47
9357 000080	8,24,28	9790 010010	58	9820 110037	39,61	9850 001089	51,55	MG53 002501	49
9357 000090	5,6	9790 020010	29,30	9822 510003	44	9850 001309	45,46	MG53 007511	49
9357 000100	31,32	9790 030020	53	9822 510013	44	9850 001311	46	MG53 007921	50
9357 000120	6,7,31,32	9790 200000	34,35,36,37,58	9822 560000	57	9850 001320	45	MG53 007922	50
9380 521220	52	9790 200001	58	9822 610000	44	9850 001340	46	MG55 000501	49
9400 000090	43	9790 201000	34,35,36,37	9822 642027	44	9850 867000	34,35,36,37	N800 005613	56
9401 000194	45,46	9790 201001	52,58	9825 550001	34,35,36,37	9850 867001	38	N800 005614	56
9401 000204	45,46	9790 315002	53	9825 810302	44	9850 867003	53	N800 005615	56
9700 100040	56	9800 130104 R	47	9825 810417	47	9870 001112	12	N800 005641	56
9700 100094	12	9800 130105	47	9830 501010	34,35,36,37,53			N800 005642	56
				9830 502014	38			N800 005643	56
				9840 104001	39,44,55,57			N800 005644	56

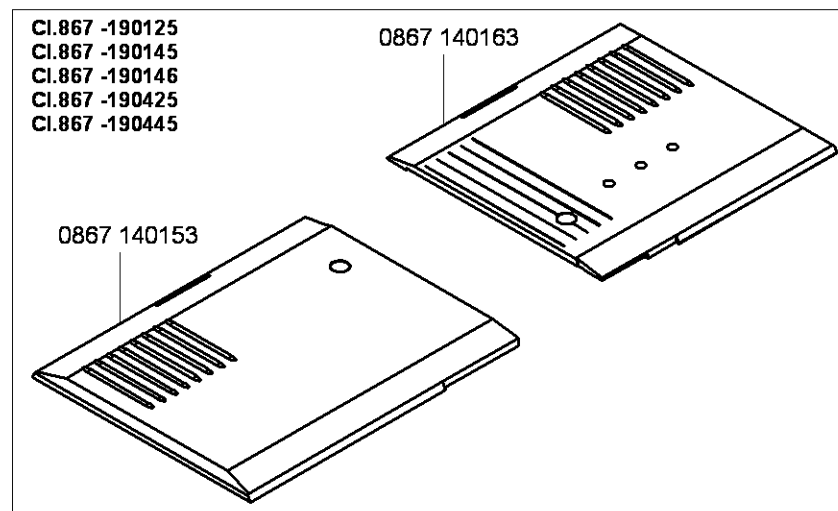
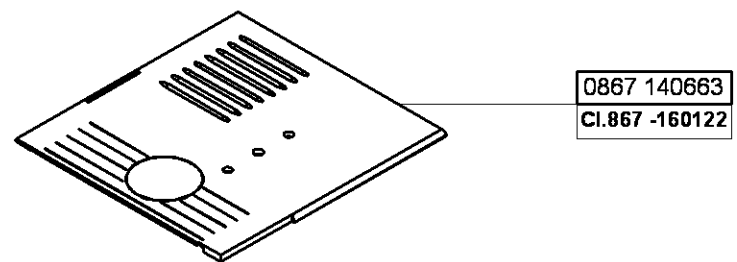
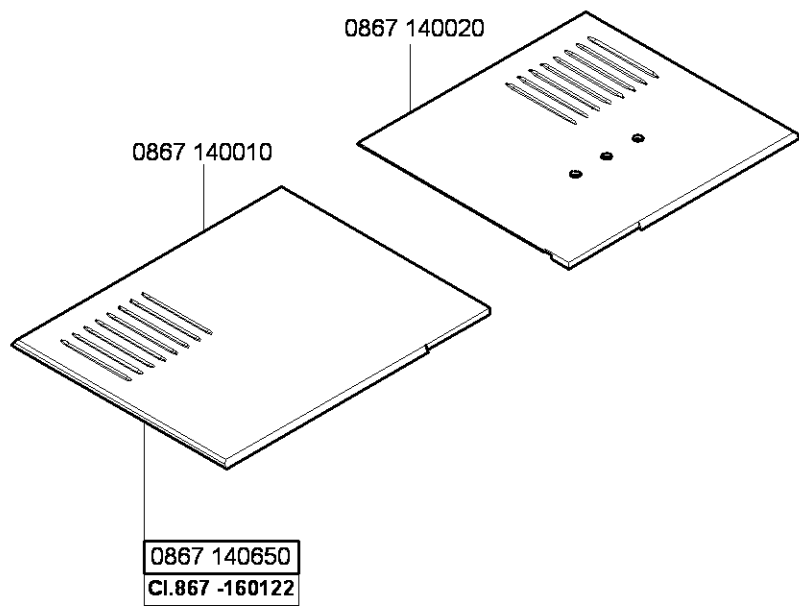

Befestigungsteile für Nähmaschinen
Fastening parts for Sewing equipment

* bis 12.07 - 211 1033

9202 002087

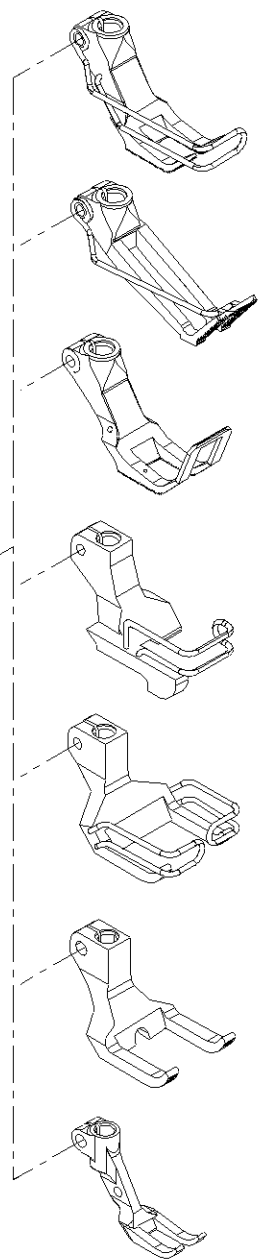

9202 002057

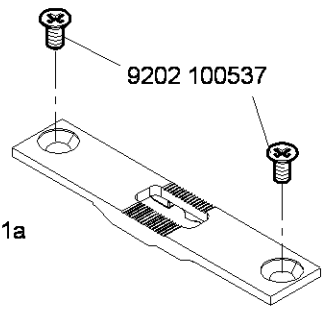
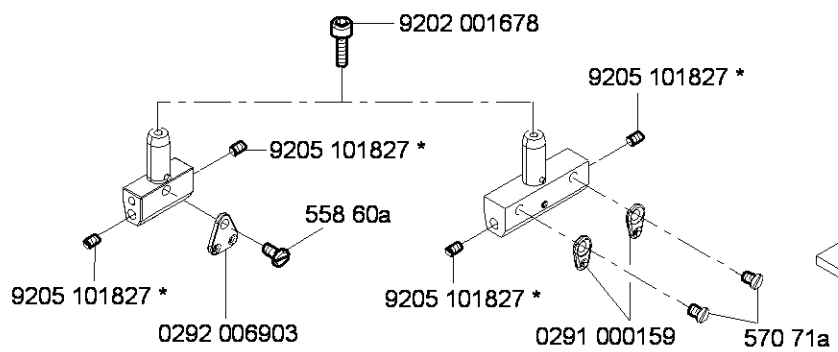
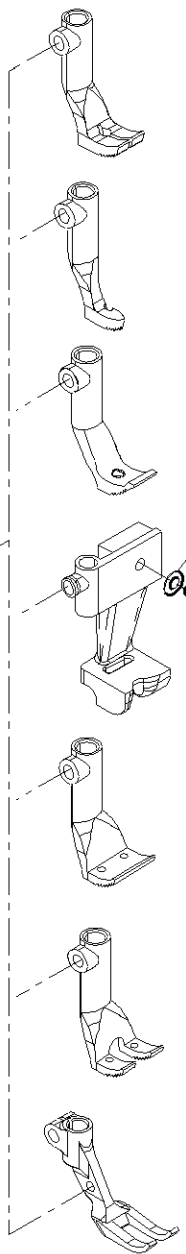

9330 000087
9203 003652

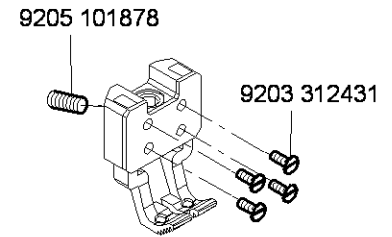
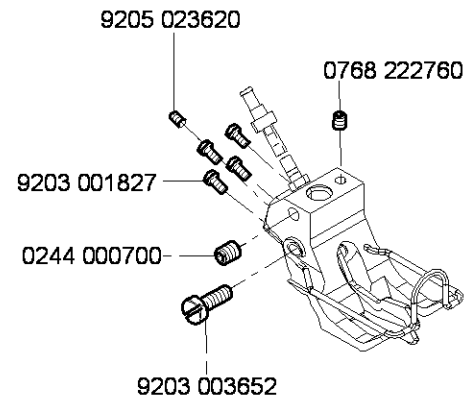
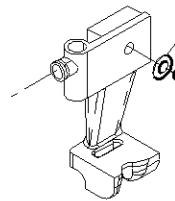

9202 001637
9330 000067

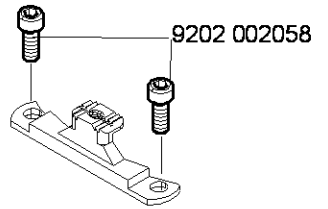
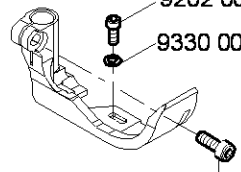

9202 002067



Pneumatische Anschluss/Pneumatic connection

Die Näheinrichtungen: E24/6/9, E24/8/9, E24/10/9, E24/12/9, E24/8/12, E24/10/12, E24/12/12, E24/14/12, beinhalten auch die unten abgebildete Komponente.

The following sewing equipments: E24/6/9, E24/8/9, E24/10/9, E24/12/9, E24/8/12, E24/10/12, E24/12/12, E24/14/12, include also the below reproduced component.

0867 590064

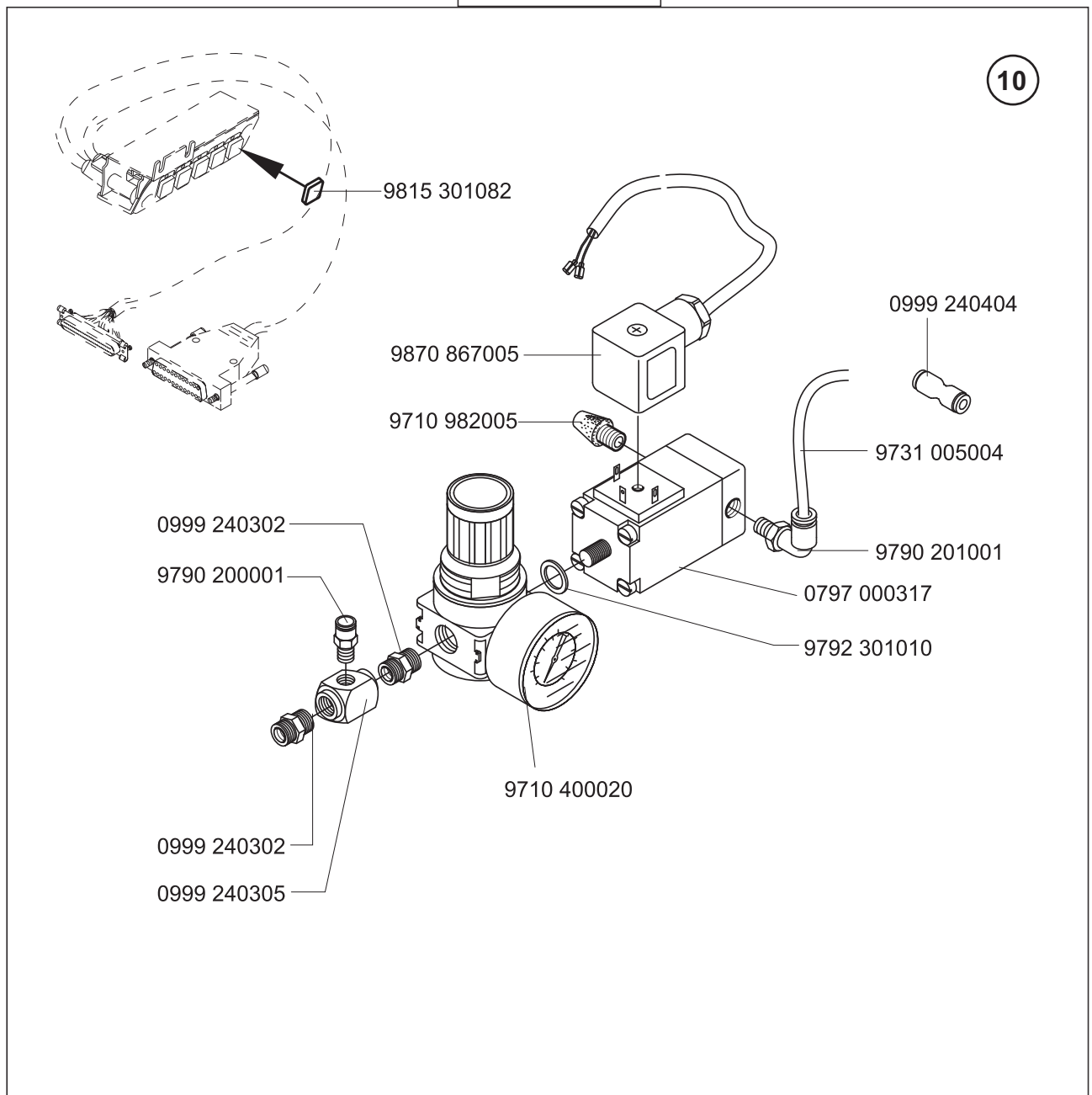



E1

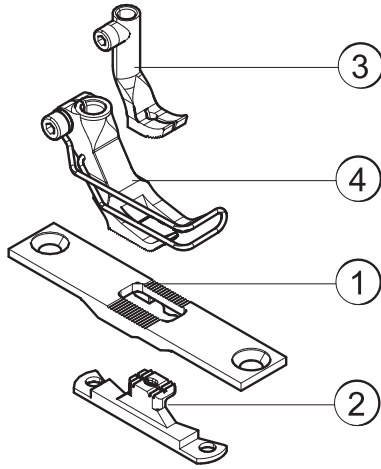

E2

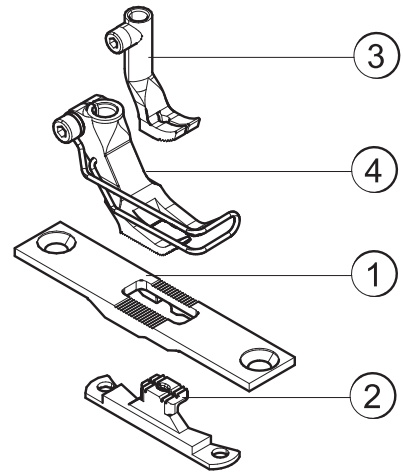

E3

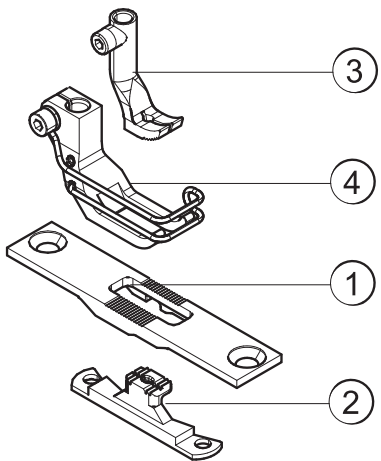

E4

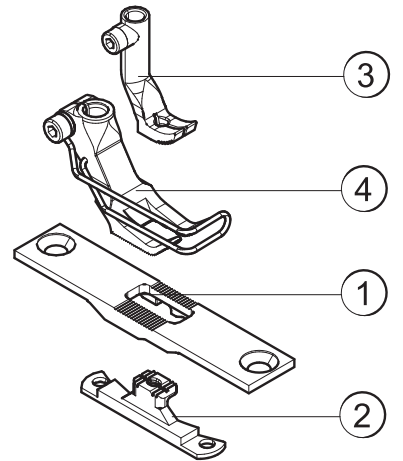

E5

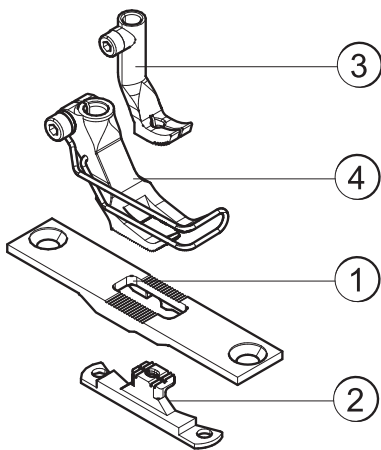

E6

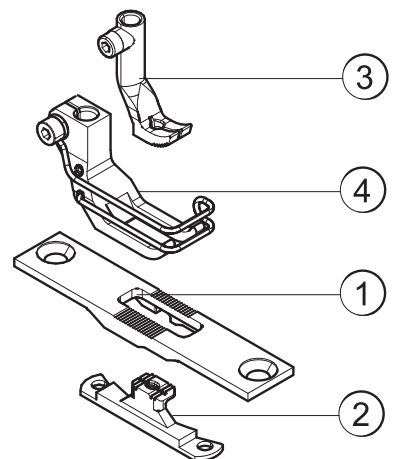



E7

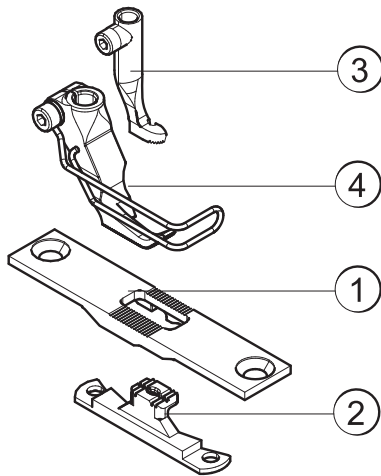

E8

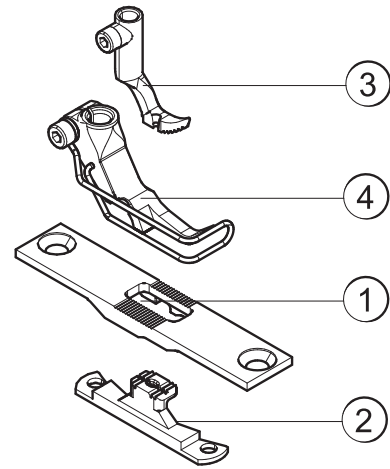

E11

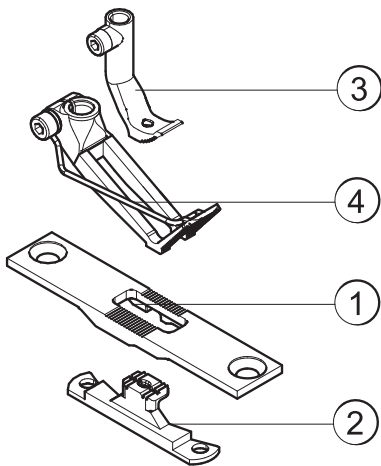

E12

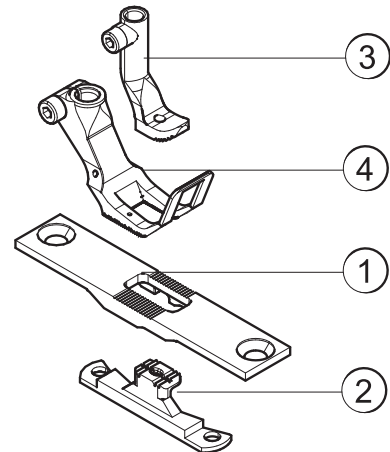

E14

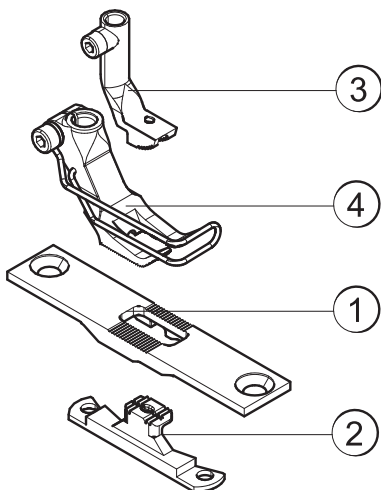

E15

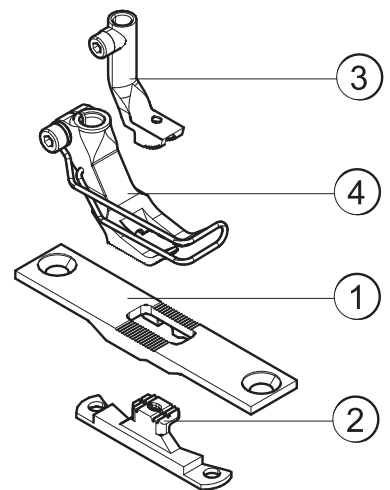



E16

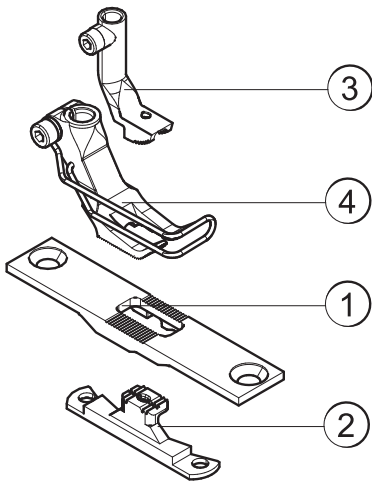

E17

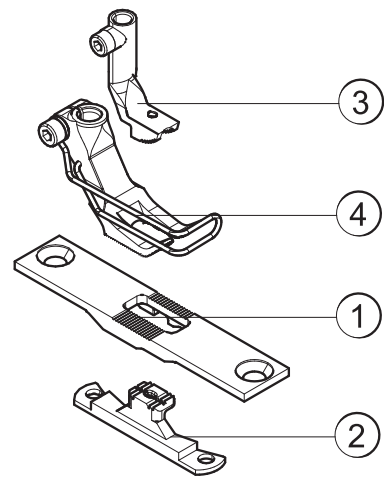

E18

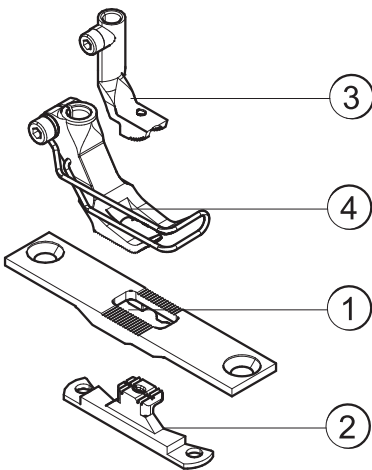

E25

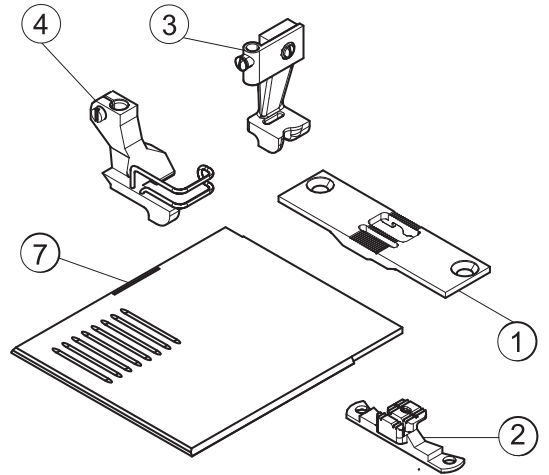

E26

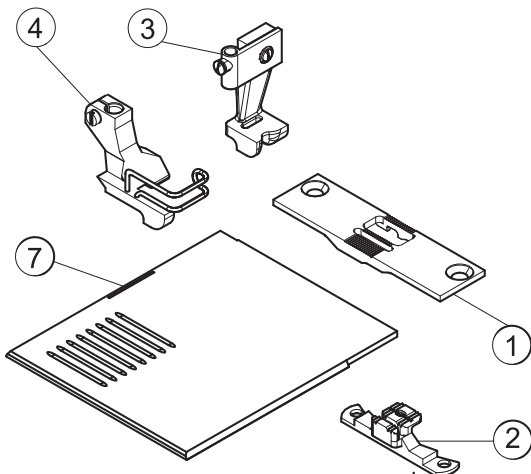



E36

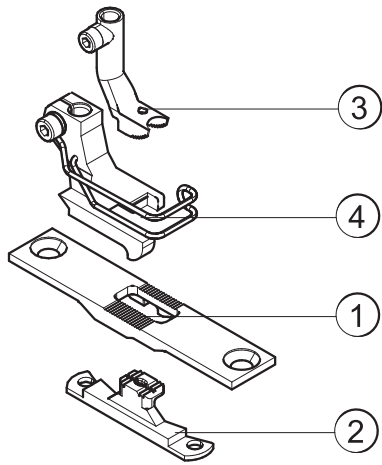

E38

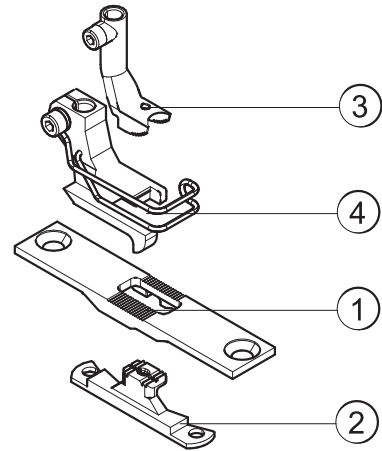

E70/6
E71/6

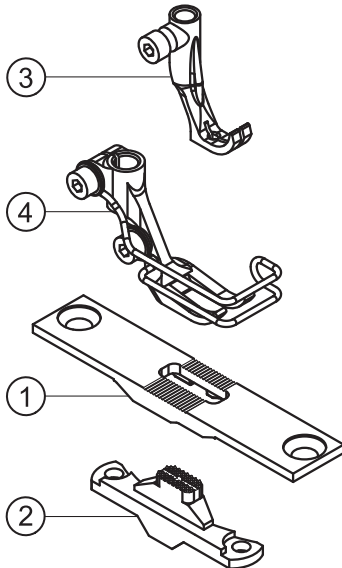



E101

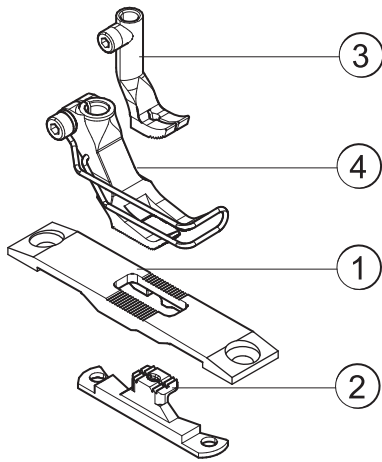

E102

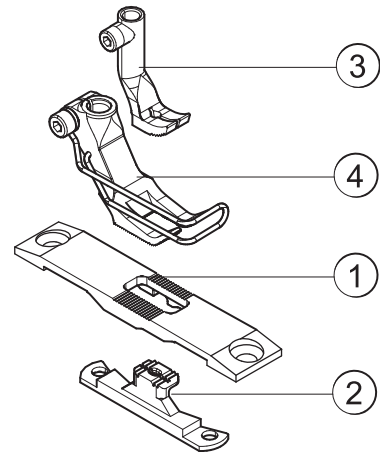



E21/4

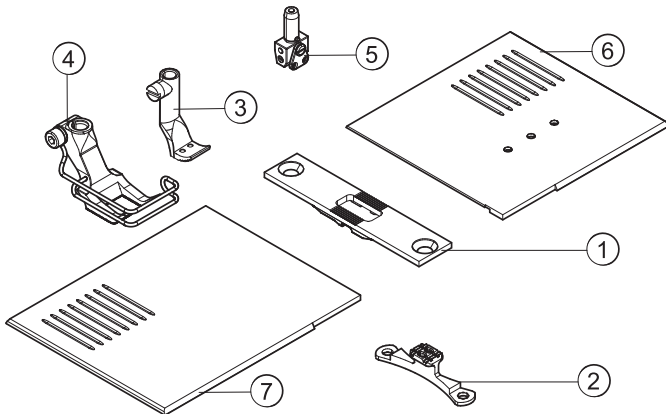

E21/5

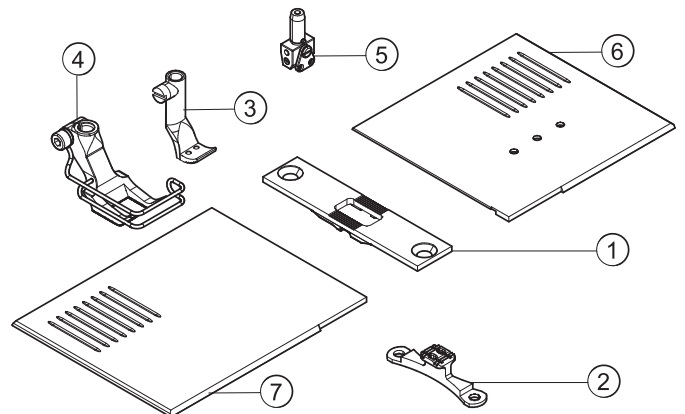

E21/6

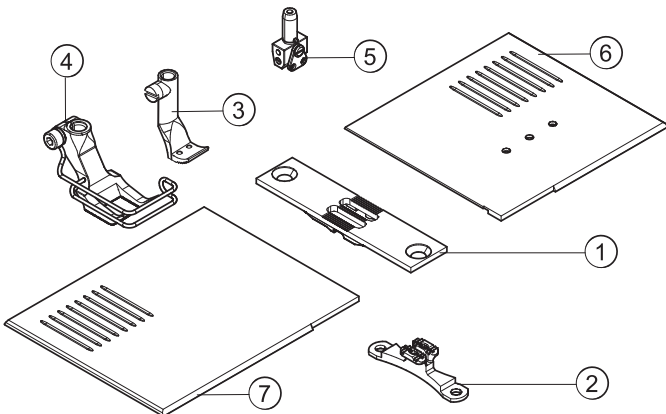

E21/8

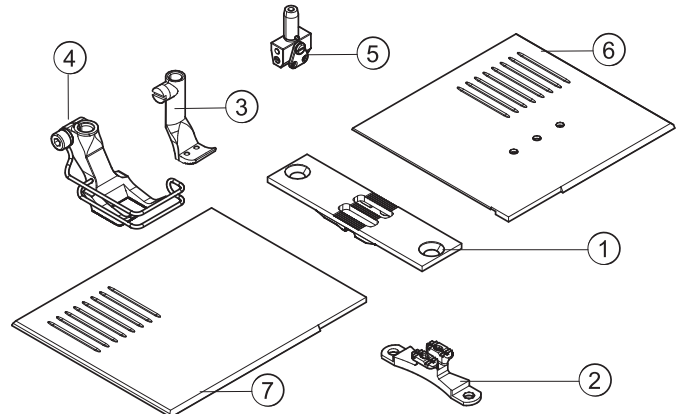

E21/10

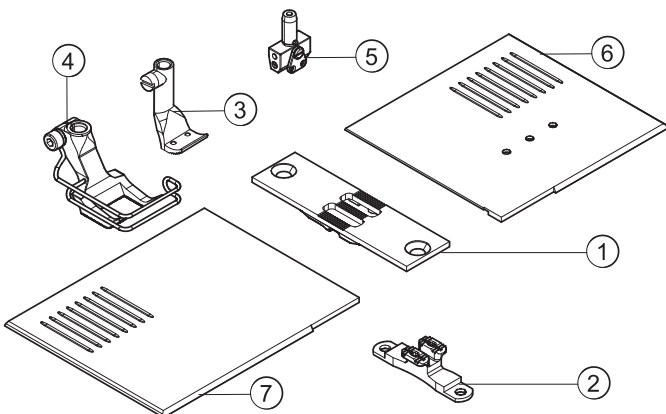

E21/12

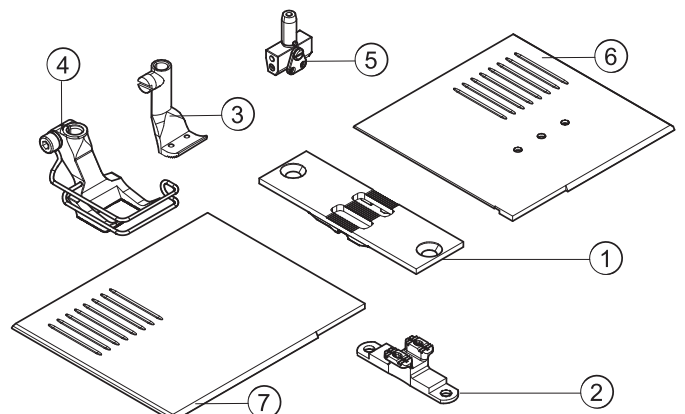



E21/14

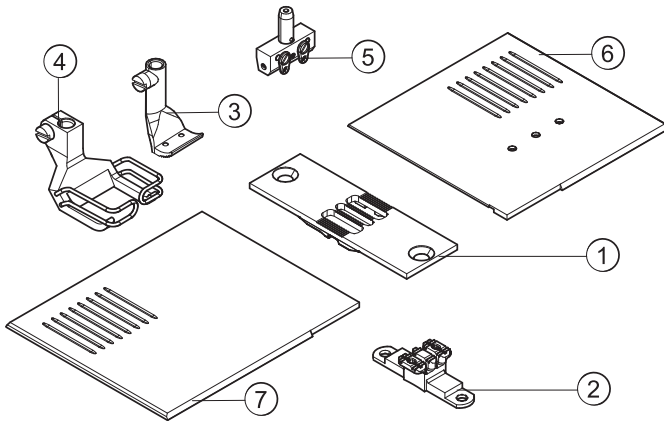

E21/16

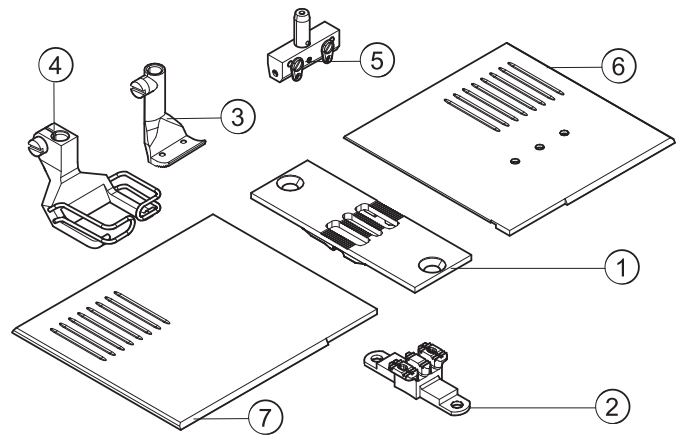

E21/18

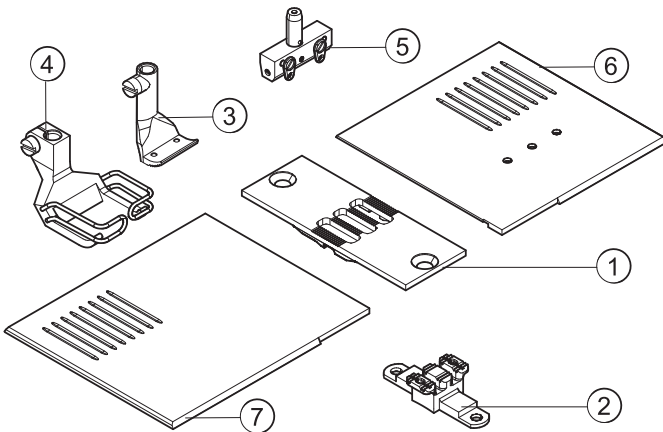

E21/20

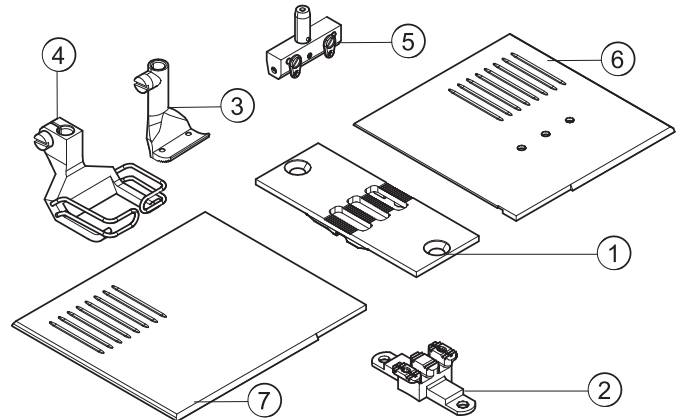

E21/22

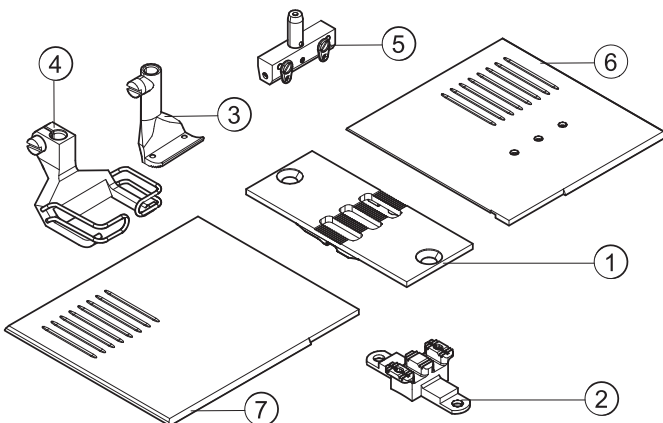

E21/50

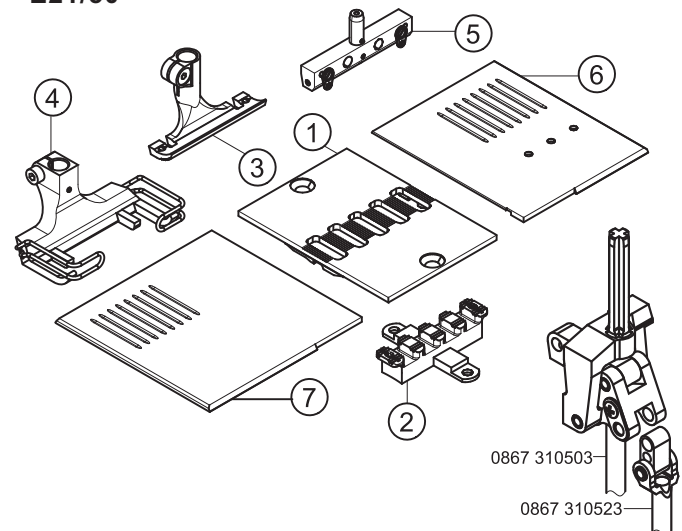



E22/6/9

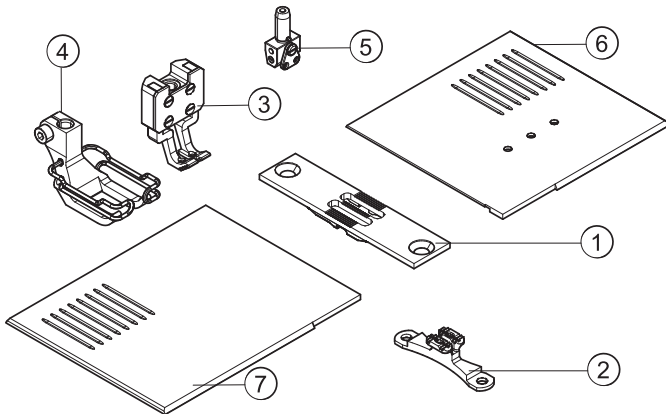

E22/8/6

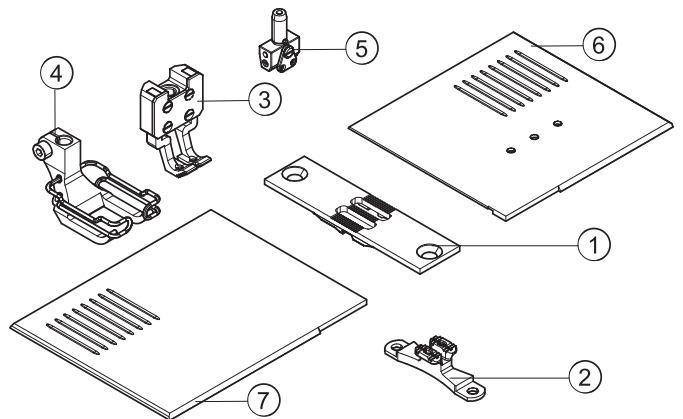

E22/8/9

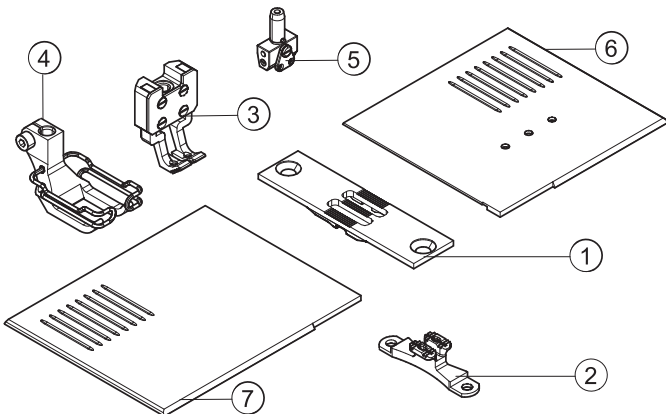

E22/10/6

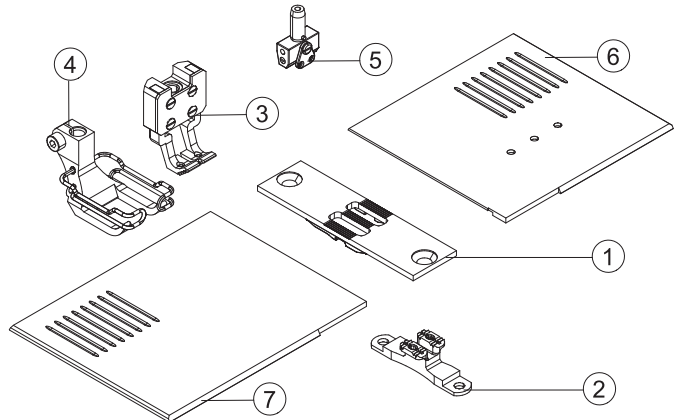

E22/10/9

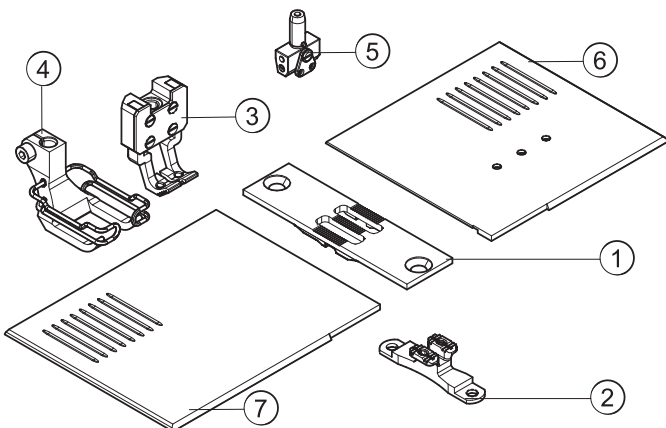

E22/10/12

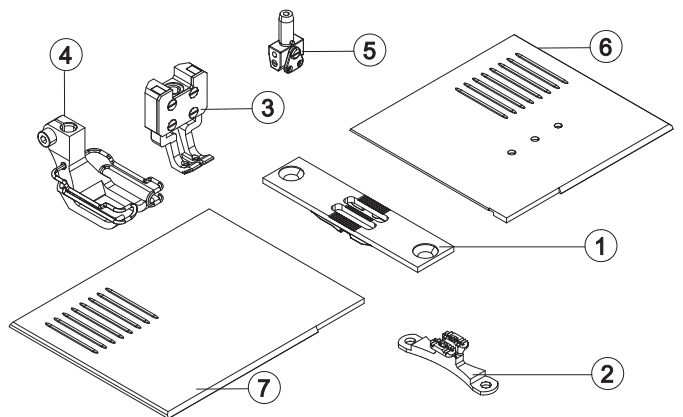



E22/12/9

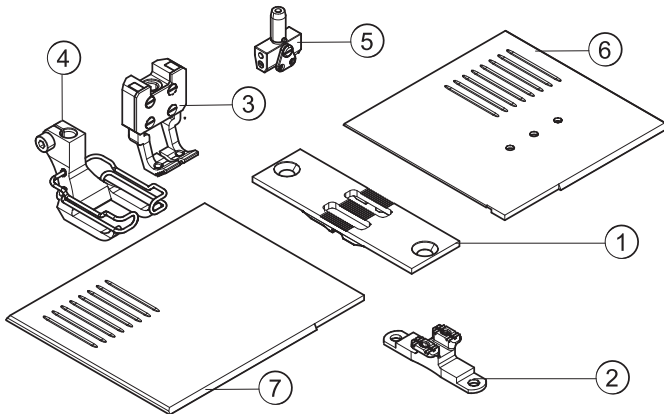

E22/12/12

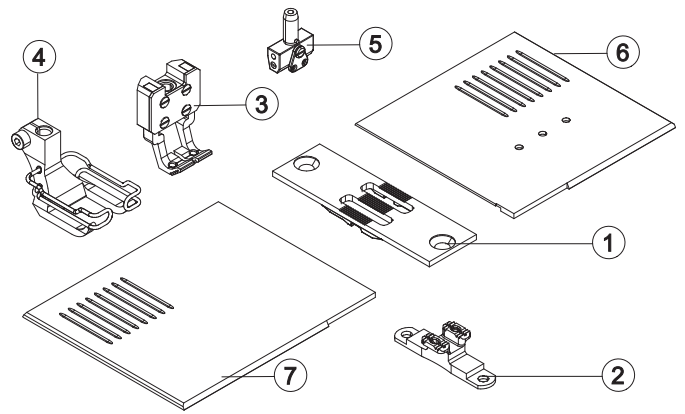

E22/14/12

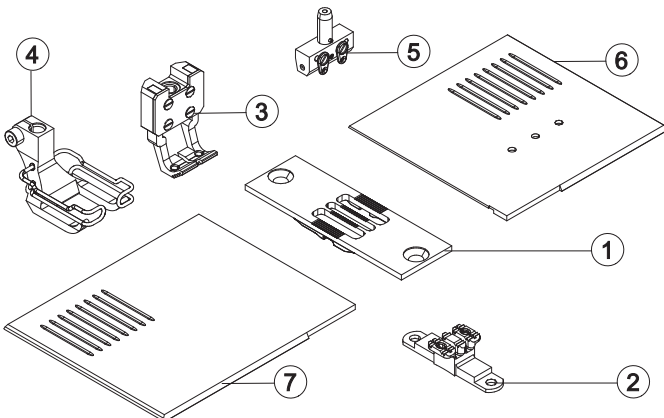

E23/10

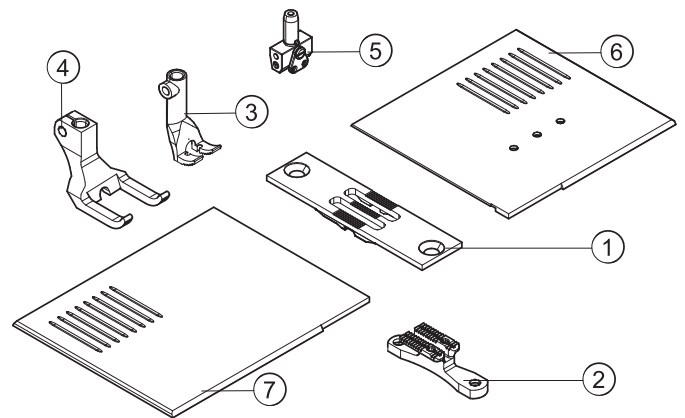

E23/12

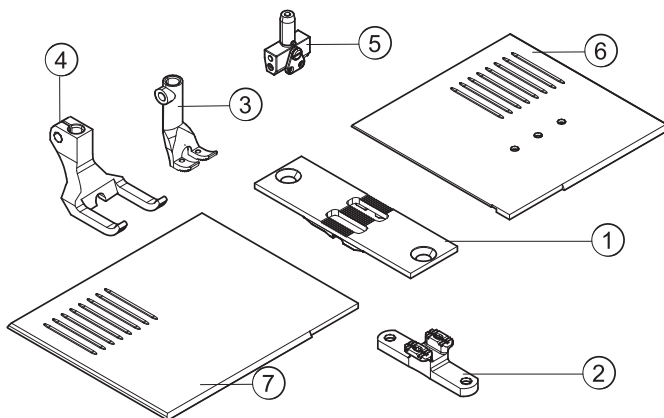



E24/6/9

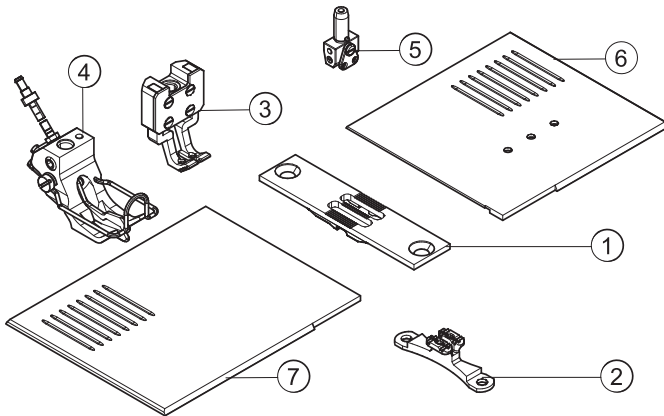

10 siehe Blatt 1/see page 1

E24/8/9

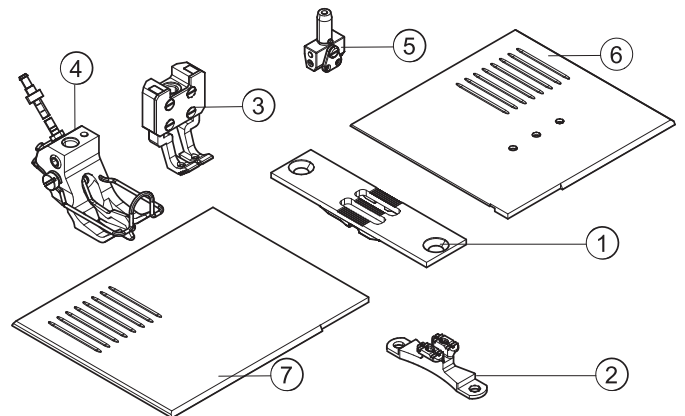

10 siehe Blatt 1/see page 1

E24/10/9

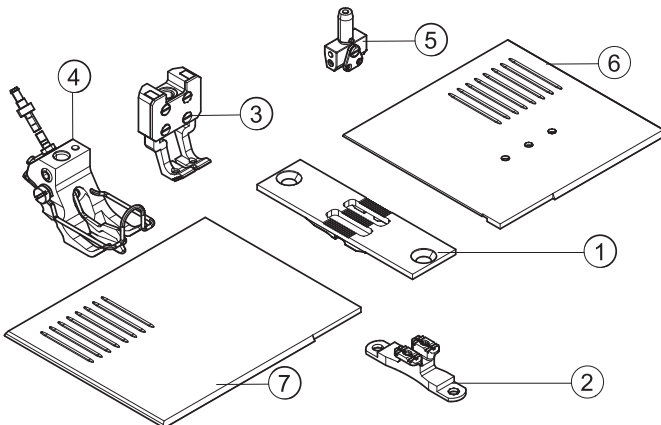

10 siehe Blatt 1/see page 1

E24/12/9

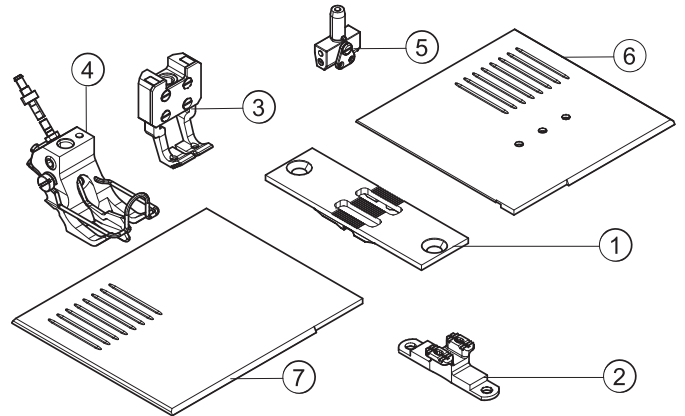

10 siehe Blatt 1/see page 1

E24/8/12

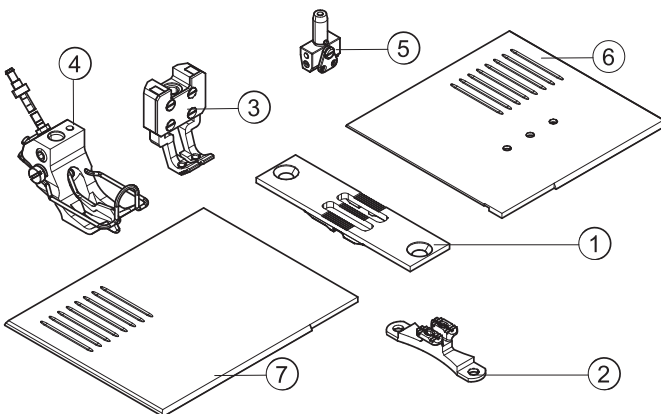

10 siehe Blatt 1/see page 1

E24/10/12

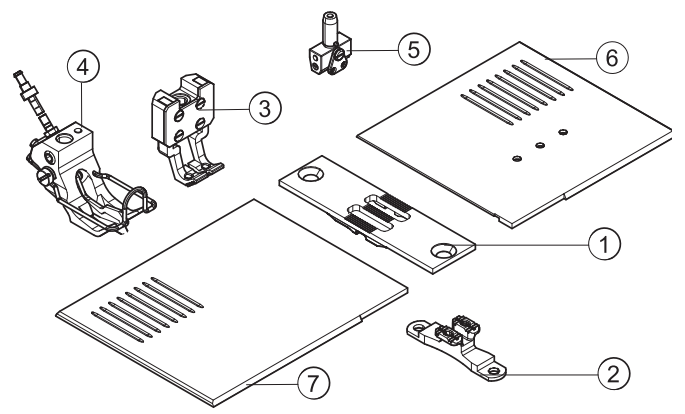

10 siehe Blatt 1/see page 1



E24/12/12

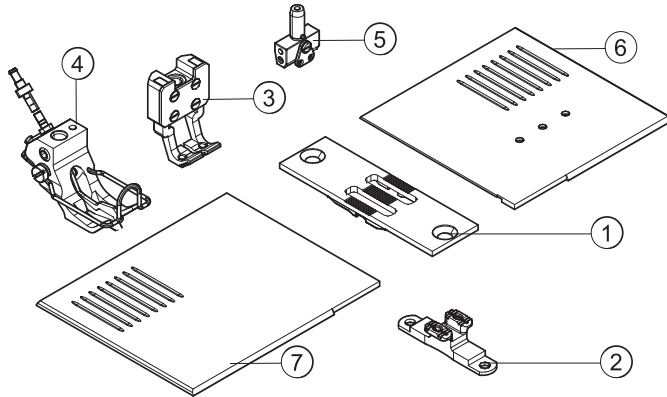

10 siehe Blatt 1/see page 1

E24/14/12

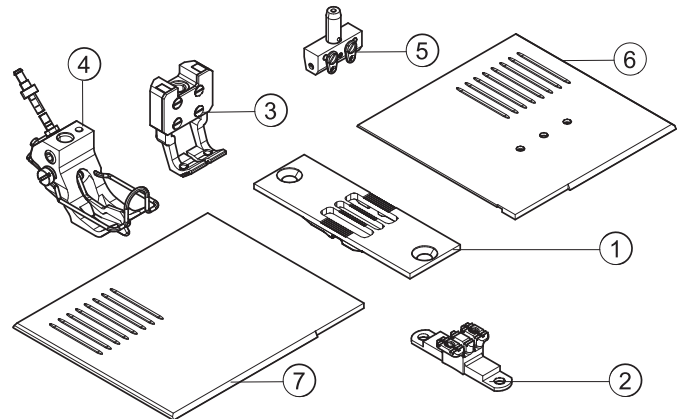

10 siehe Blatt 1/see page 1

E51/8/9

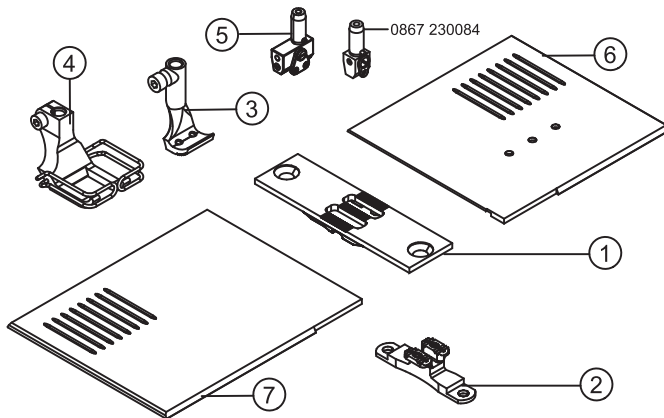

E51/10/9

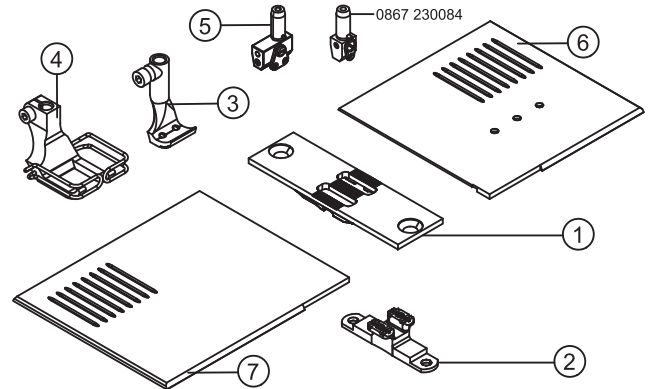

E51/12/9

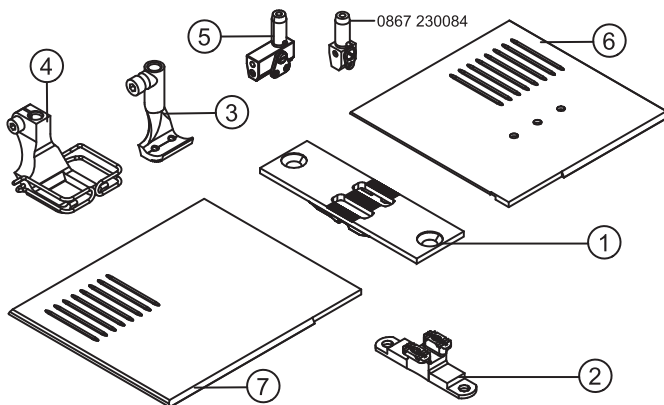

E51/14/9

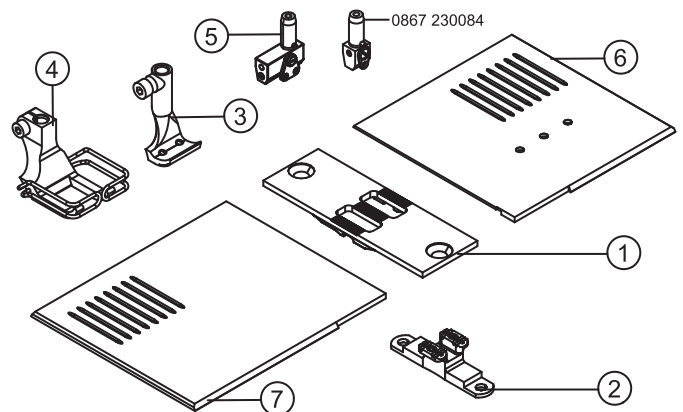



E75/3,2/6
E75/4,8/6
E75/6,4/6

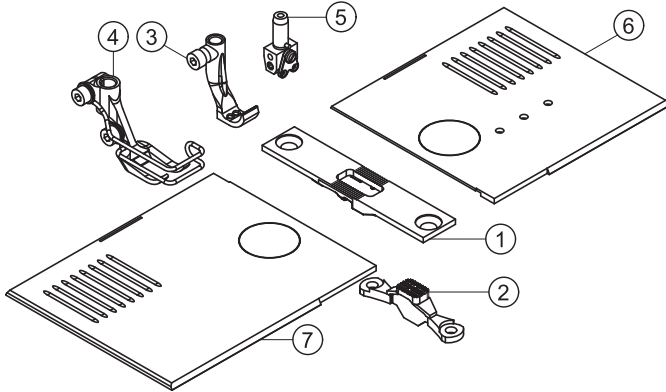

E121/6/6

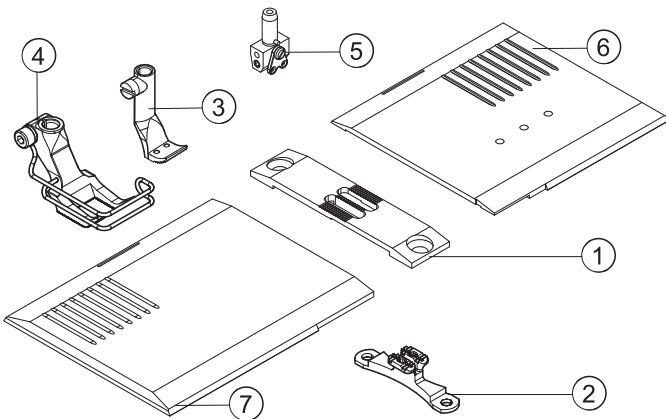

E121/8/6

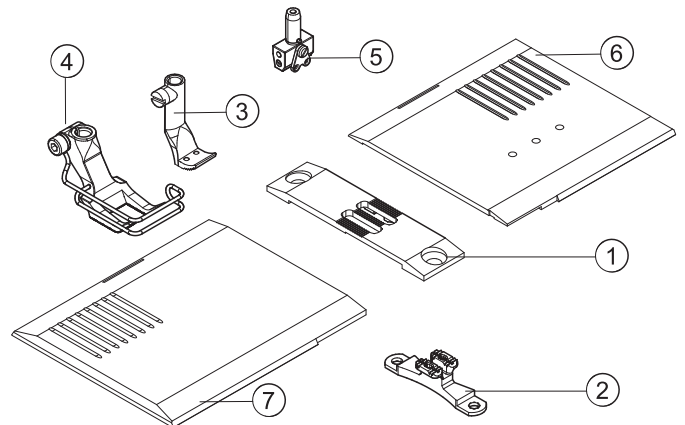

E121/10/6

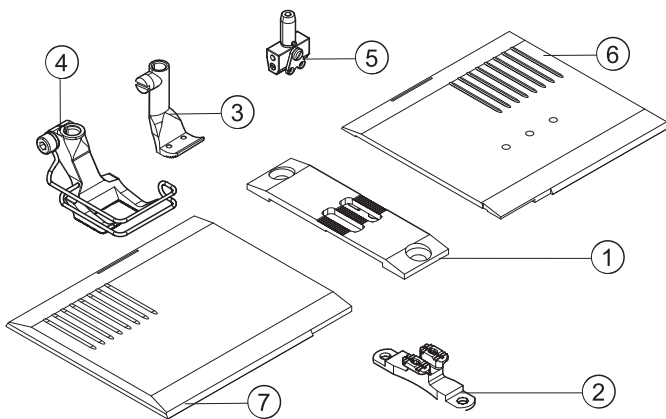

E121/12/6

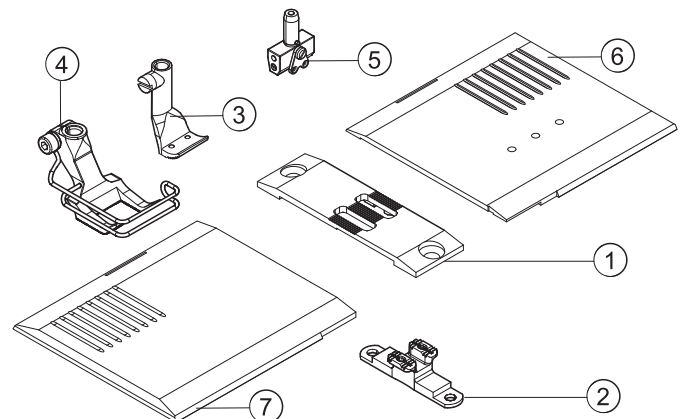



E122/6/9

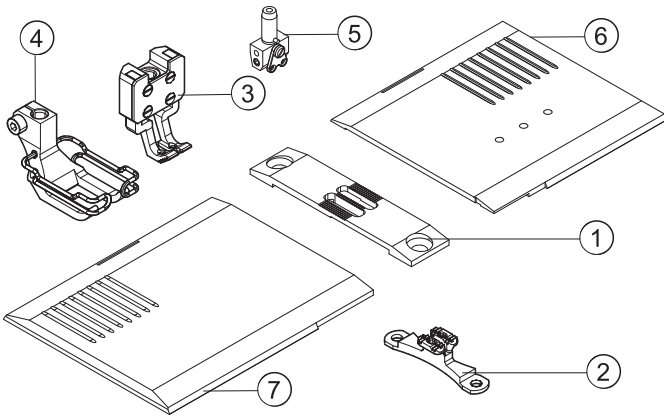

E122/8/9

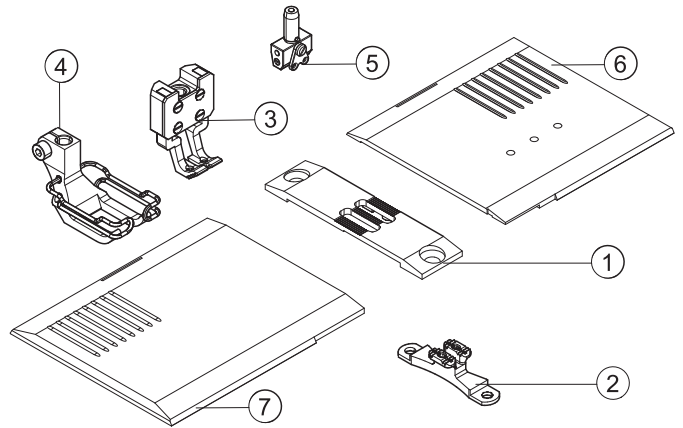

E122/10/9

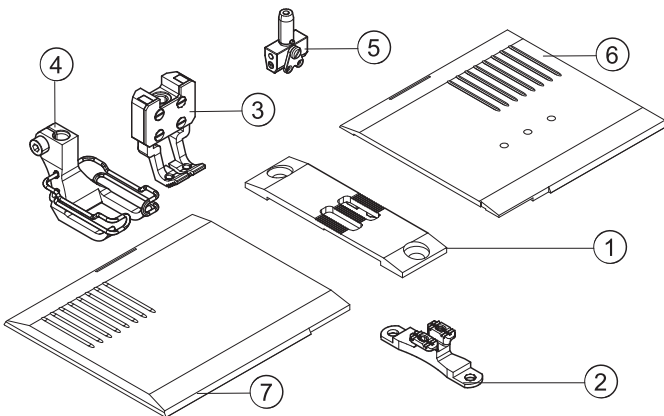

E122/12/9

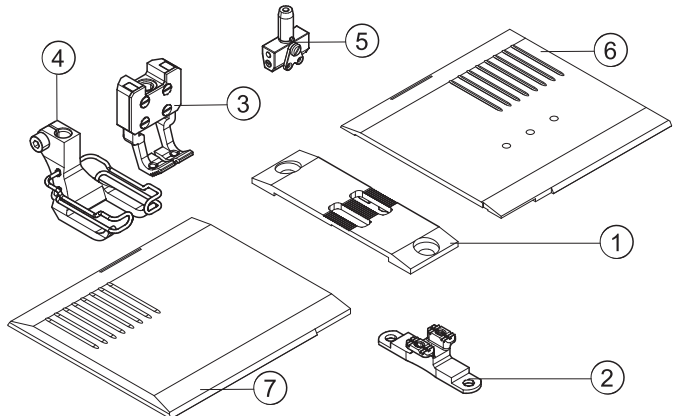



Näheinrichtungen Sewing equipment 867 Standard

Ausgabe
Edition
02.06

Blatt 15
Page

Fortsetzung Blatt 16
Continued page

E-Nr. E-No. Abb.-Nr. Fig.No.	Für Unterklasse / For Subclass Verwendungszweck / Use	Material No. / Material Nr.	Stichplatte Throat plate		Transporteur Feed dog				Presserfuß Presser foot	Transp. Fuß Feeding foot								
			①						②	④			③					
			Stichplatte / Throat plate	Schieber, links / Slide, left	Schieber, rechts / Slide, right	Stichlochgröße / Stitch hole size mm	Sägeverzahnung / Serrated mm	Säge-schrägverzahnung / Serrated, oblique mm	Kreuzverzahnung / Cross toothed mm	Dachverzahnung / Roof-shaped mm	Drückerfuß / Presser foot	Unverzahnung / Non toothed	Hüpfersfuß, kreuzverz. / Skipping f., cross toothed	Ausgleichfuß / Compensating foot	Kreuzverzahnung / Cross toothed mm	Unverzahnung / Non toothed	Nadelhalter / Needle holder	Nadelsystem / -dicke / Needle system / -size
E1	-190020; -190040; -190122; -190142; -190322; -190342 Näheinrichtung, Nadelstärke Nm 110-140, Stichlänge max. 6 mm, für mittelschweres Nähgut. Sewing equipment, needle size Nm 110-140, stitch length max. 6 mm, for medium weight material.	0867 E00106	0867 200010			2,2 x 3,2	0867 210010				0367 220993				0467 220013			134-35/130
E2	-190020; -190040; -190122; -190142; -190322; -190342 Näheinrichtung, Nadelstärke Nm 110-140, Stichlänge max. 9 mm, für mittelschweres Nähgut. Sewing equipment, needle size Nm 110-140, stitch length max. 9 mm, for medium weight material.	0867 E00209	0867 200020			2,2 x 3,2	0867 210010				0467 220043				0467 220013			134-35/130
E3	-190020; -190040; -190122; -190142; -190322; -190342 Näheinrichtung, Nadelstärke Nm 110-140, Stichlänge max. 12 mm, für mittelschweres Nähgut. Sewing equipment, needle size Nm 110-140, stitch length max. 12 mm, for medium weight material.	0867 E00312	0867 200030			2,2 x 3,2	0867 210010				0768 220013				0467 220013			134-35/130
E4	-190020; -190040; -190122; -190142; -190322; -190342 Näheinrichtung, Nadelstärke Nm 140-170, Stichlänge max. 6 mm, für mittelschweres Nähgut. Sewing equipment, needle size Nm 140-170, stitch length max. 6 mm, for medium weight material.	0867 E00406	0867 200010			3,0 x 3,7	0867 210020				0367 220993				0768 220113			134-35/160
E5	-190020; -190040; -190122; -190142; -190322; -190342 Näheinrichtung, Nadelstärke Nm 140-170, Stichlänge max. 9 mm, für mittelschweres Nähgut. Sewing equipment, needle size Nm 140-170, stitch length max. 9 mm, for medium weight material.	0867 E00509	0867 200020			3,0 x 3,7	0867 210020				0467 220043				0768 220113			134-35/160

■ = Änderung / Modification



Näheinrichtungen 867 Standard

Sewing equipment

Ausgabe
Edition
02.06

Blatt 16
Page

Fortsetzung Blatt 17
Continued page

E-Nr. E-No.	Für Unterklasse / For Subclass	Abb.-Nr. Fig.No.	Verwendungszweck / Use	Material No. / Material Nr.	Stichplatte Throat plate		Transporteur Feed dog				Presserfuß Presser foot		Transp. Fuß Feeding foot							
					①															
					Stichplatte / Throat plate	Schieber, links / Slide, left	Schieber, rechts / Slide, right	Stichlochgröße / Stich hole size mm	Sägeverzahn / Serrated mm	Säge-schrägverzahn / Serrated, oblique mm	Kreuzverzahn / Cross toothed mm	Dachverzahn / Roof-shaped mm	Drückerfuß / Presser foot	Unverzahn / Non toothed	Hüpfersfuß, kreuzverz. / Skipping f., cross toothed	Ausgleichfuß / Compensating foot	Kreuzverzahn / Cross toothed mm	Unverzahn / Non toothed	Nadelhalter / Needle holder	Nadelsystem / -dicke / Needle system / -size
E6	-190020; -190040; -190122; -190142; -190322; -190342 Näheinrichtung, Nadelstärke Nm 140-170, Stichtlänge max. 12 mm, für mittelschweres Nähgut. Sewing equipment, needle size Nm 140-170, stitch length max. 12 mm, for medium weight material.			0867 E00612	0867 200030			3,0 x 3,7	0867 210020				0768 220013					0768 220113		134-35/160
E7	-190020; -190040; -190122; -190142; -190322; -190342 Näheinrichtung für kantennahe Näharbeiten, ab 1 mm rechts der Nadel, Nadelstärke Nm 110-140, Stichtlänge max. 6 mm, für mittelschweres Nähgut. Sewing equipment for stitching on edges, from 1 mm on the right from the needle, needle size Nm 110-140, stitch length max. 6 mm, for medium weight material.			0867 E00706	0867 200010			2,2 x 3,2	0867 210010				0367 220293					0067 220713		134-35/130
E8	-190020; -190040; -190122; -190142; -190322; -190342 Näheinrichtung für kantennahe Näharbeiten, ab 1 mm links der Nadel, Nadelstärke Nm 110-140, Stichtlänge max. 6 mm, für mittelschweres Nähgut. Sewing equipment for stitching on edges, from 1 mm on the left from the needle, needle size Nm 110-140, stitch length max. 6 mm, for medium weight material.			0867 E00806	0867 200010			2,2 x 3,2	0867 210010				0367 220303					0067 220703		134-35/130
E11	-190020; -190040; -190122; -190142; -190322; -190342 Näheinrichtung zum Überklettern starker Quernähte, Nadelstärke Nm 110-140, Stichtlänge max. 9 mm, für mittelschweres Nähgut. Sewing equipment for stitching of cross seams in thick material, needle size Nm 110-140, stitch length max. 9 mm, for medium weight material.			0867 E01109	0867 200020			2,2 x 3,2	0867 210010				0767 220013					0467 220483		134-35/130
E12	-190020; -190040; -190122; -190142; -190322; -190342 Näheinrichtung für wattiertes Nähgut, Nadelstärke Nm 110-140, Stichtlänge max. 6 mm, für mittelschweres Nähgut. Sewing equipment for padded material, needle size Nm 110-140, stitch length max. 6 mm, for medium weight material.			0867 E01206	0867 200010			2,2 x 3,2	0867 210010				0367 221543					0367 221553		134-35/130

■ = Änderung / Modification



E-Nr. E-No.	Für Unterklasse / For Subclass	Abb.-Nr. Fig.No.	Verwendungszweck / Use	Material No. / Material Nr.	Stichplatte Throat plate		Transporteur Feed dog				Presserfuß Presser foot	Transp. Fuß Feeding foot	Nadelhalter/ Needle holder	Nadelsystem/ -dicke / -size / Needle system/ -size				
					①						②	④			③			
E14	-190020; -190040;-190122; -190142; -190322; -190342 Näheinrichtung für Kedararbeiten, Kedernut 4 mm, Nadelstärke Nm 110-140. Stichlänge max. 6 mm, für mittelschweres Nähgut. Sewing equipment for welt attaching operations, welt groove 4 mm, needle size Nm 110-140. Stitch length max. 6 mm, for medium weight material.			0867 E01406	0867 200010			2,2 x 3,2	0867 210010			0367 220773			0167 220583			134-35/130
E15	-190020; -190040;-190122; -190142; -190322; -190342 Näheinrichtung für Kedararbeiten, Kedernut 5 mm, Nadelstärke Nm 110-140, Stichlänge max. 6 mm, für mittelschweres Nähgut. Sewing equipment for welt attaching operations, welt groove 5 mm, needle size Nm 110-140, stitch length max. 6 mm, for medium weight material.			0867 E01506	0867 200010			2,2 x 3,2	0867 210010			0367 220783			0167 220603			134-35/130
E16	-190020; -190040;-190122; -190142; -190322; -190342 Näheinrichtung für Kedararbeiten, Kedernut 6 mm, Nadelstärke Nm 110-140, Stichlänge max. 6 mm, für mittelschweres Nähgut. Sewing equipment for welt attaching operations, welt groove 6 mm, needle size Nm 110-140, stitch length max. 6 mm, for medium weight material.			0867 E01606	0867 200010			2,2 x 3,2	0867 210010			0367 220793			0167 220363			134-35/130
E17	-190020; -190040;-190122; -190142; -190322; -190342 Näheinrichtung für Kedararbeiten, Kedernut 7 mm, Nadelstärke Nm 110-140, Stichlänge max. 6 mm, für mittelschweres Nähgut. Sewing equipment for welt attaching operations, welt groove 7 mm, needle size Nm 110-140, stitch length max. 6 mm, for medium weight material.			0867 E01706	0867 200010			2,2 x 3,2	0867 210010			0367 220803			0167 220633			134-35/130
E18	-190020; -190040;-190122; -190142; -190322; -190342 Näheinrichtung für Kedararbeiten, Kedernut 8 mm, Nadelstärke Nm 110-140, Stichlänge max. 6 mm, für mittelschweres Nähgut. Sewing equipment for welt attaching operations, welt groove 8 mm, needle size Nm 110-140, stitch length max. 6 mm, for medium weight material.			0867 E01806	0867 200010			2,2 x 3,2	0867 210010			0367 220813			0167 220653			134-35/130



Näheinrichtungen 867 Standard

Sewing equipment

Ausgabe
Edition
12.08

Blatt 18
Page

Ersetzt Ausgabe
Replaced edition
02.06

Fortsetzung Blatt 19
Continued page

E-Nr. E-No.	Für Unterklasse / For Subclass	Abb.-Nr. Fig.No.	Verwendungszweck / Use	Material No. / Material Nr.	Stichplatte Throat plate		Stichlochgröße / Stich hole size mm	Sägeverzahnung / Serrated mm	Säge-schrägverzahnung / Serrated, oblique mm	Kreuzverzahnung / Cross toothed mm	Dachverzahnung / Roof-shaped mm	Transporteur Feed dog		Drückerfuß / Presser foot	Unverzahnung / Non toothed	Hüpfertfuß, kreuzverz. / Skipping f., cross toothed	Ausgleichfuß / Compensating foot	Kreuzverzahnung / Cross toothed mm	Unverzahnung / Non toothed	Messer/Knife	Nadelstange/ Needle bar	Nadelsystem / -dicke / Needle system / -size
					①	⑦						②	④									
E25	-190020; -190040; -190122; -190142; -190322; -190342 Näheinrichtung zum Vor- oder Einnähen von Keder, Kedernut 5 mm, Nadelstärke Nm 110-140, Stichlänge max. 6 mm, für mittelschweres Nähgut. Sewing equipment for stitching and welt attaching operations, welt groove 5 mm, needle size Nm 110-140, stitch length max. 6 mm, for medium weight material.			0867 E02506	0867 200040	0867 140090	2,2 x 3,2	0867 210040					0367 220653					0067 220924				134-35/130
E26	-190020; -190040; -190122; -190142; -190322; -190342 Näheinrichtung zum Vor- oder Einnähen von Keder, Kedernut 6 mm, Nadelstärke Nm 110-140, Stichlänge max. 6 mm, für mittelschweres Nähgut Sewing equipment for stitching and welt attaching operations, welt groove 6 mm, needle size Nm 110-140, stitch length max. 6 mm, for medium weight material.			0867 E02606	0867 200040	0867 140090	2,2 x 3,2	0867 210040					0367 220663					0067 220934				134-35/130
E36	-190020; -190040; -190122; -190142; -190322; -190342 Näheinrichtung zum Auf- oder Einnähen von Kordel, Kordelnut 6 mm, Nadelstärke Nm 110-140, Stichlänge max. 6 mm, für mittelschweres Nähgut. Sewing equipment for stitching and cord attaching operations, cord groove 6 mm, needle size Nm 110-140, stitch length max. 6 mm, for medium weight material.			0867 E03606	0867 200010		2,2 x 3,2	0867 210010					0367 220363					0067 220863				134-35/130
E38	-190020; -190040; -190122; -190142; -190322; -190342 Näheinrichtung zum Auf- oder Einnähen von Kordel, Kordelnut 8 mm, Nadelstärke Nm 110-140, Stichlänge max. 6 mm, für mittelschweres Nähgut. Sewing equipment for stitching and cord attaching operations, cord groove 8 mm, needle size Nm 110-140, stitch length max. 6 mm, for medium weight material.			0867 E03806	0867 200010		2,2 x 3,2	0867 210010					0367 220373					0367 220383				134-35/130

■ = Änderung / Modification



Näheinrichtungen 867 Standard

Sewing equipment

Ausgabe
Edition
05.11

Blatt 19
Page

Ersetzt Ausgabe
Replaced edition
09.10

Fortsetzung Blatt 20
Continued page

E-Nr. E-No.	Für Unterklasse / For Subclass	Abb.-Nr. Fig.No.	Verwendungszweck / Use	Material No. / Material Nr.	Stichplatte Throat plate		Transporteur Feed dog	Presserfuß Presser foot	Transp. Fuß Feeding foot		
					①	②					
E70/6	-160122 Näheinrichtung, Nadelstärke Nm 80-120, Stichlänge max. 6 mm, für leichtes und mittelschweres Nähgut. Sewing equipment, needle size Nm 80-120, stitch length max. 6 mm, for light and medium weight material.			0867 E07006	0867 201200		Ø 2	0867 211200	0867 220644	0867 220604	134-35/110
E71/6	-160122 Näheinrichtung, Nadelstärke Nm 80-120, Stichlänge max. 6 mm, für leichtes und mittelschweres Nähgut. Sewing equipment, needle size Nm 80-120, stitch length max. 6 mm, for light and medium weight material.			0867 E07106	0867 201200		Ø 2	0867 211210	0867 220654	0867 220614	134-35/110
E101	-190125; -190145; -190425; -190445; -190146 Näheinrichtung, Nadelstärke Nm 110-140, Stichlänge max. 6 mm, für mittelschweres Nähgut; mit Kurzfadenabschneider. Sewing equipment, needle size Nm 110-140, stitch length max. 6 mm, for medium weight material; with short thread trimmer.			0867 E10106	0867 200050		2,2 x 3,2	0867 210050	0367 220993	0467 220013	134-35/120
E102	-190125; -190145; -190425; -190445; -190146 Näheinrichtung, Nadelstärke Nm 110-140, Stichlänge max. 9 mm, für mittelschweres Nähgut; mit Kurzfadenabschneider. Sewing equipment, needle size Nm 110-140, stitch length max. 9 mm, for medium weight material; with short thread trimmer.			0867 E10209	0867 200060		2,2 x 3,2	0867 210050	0467 220043	0467 220013	134-35/120

■ = Änderung / Modification



Näheinrichtungen 867 Standard

Sewing equipment

Ausgabe
Edition
02.06

Blatt 20
Page

Fortsetzung Blatt 21
Continued page

E-Nr. E-No.	Für Unterklasse / For Subclass	Abb.-Nr. Fig.No.	Verwendungszweck / Use	Material No. / Material Nr.	Stichplatte Throat plate			Transporteur Feed dog				Presserfuß Presser foot		Transp. Fuß Feeding foot					
					① Stichplatte / Throat plate	⑦ Schieber, links / Slide, left	⑥ Schieber, rechts / Slide, right	Stichlochgröße / Stich hole size mm	Sägeverzahnung / Serrated mm	Säge-schrägverzahnung / Serrated, oblique mm	Kreuzverzahnung / Cross toothed mm	Dachverzahnung / Roof-shaped mm	Drückerfuß / Presser foot	Unverzahnung / Non toothed	Hüpfertfuß, kreuzverz. / Skipping f., cross toothed	Ausgleichfuß / Compensating foot	Kreuzverzahnung / Cross toothed mm	Unverzahnung / Non toothed	Nadelabstand / Needle distance
E21/4	-290020; -290040; -290122; -290142; -290322; -290342 Näheinrichtung, Nadelabstand 4 mm, Nadelstärke Nm 110-140, Stichtlänge max. 6 mm, für mittelschweres Nähgut. Sewing equipment, needle gauge 4 mm, needle size Nm 110-140, stitch length max. 6 mm, for medium weight material.			0867 E02106 4	0867 200200	0867 140010	0867 140040	2,2 x 3,2	0867 210200				0367 222473			0067 222323	4	0867 230114	134-35/130
E21/5	-290020; -290040; -290122; -290142; -290322; -290342 Näheinrichtung, Nadelabstand 5 mm, Nadelstärke Nm 110-140. Stichtlänge max. 6 mm, für mittelschweres Nähgut. Sewing equipment, needle gauge 5 mm, needle size Nm 110-140. Stich length max. 6 mm, for medium weight material			0867 E02106 5	0867 200210	0867 140010	0867 140040	2,2 x 3,2	0867 210210				0367 222243			0067 222333	5	0867 230124	134-35/130
E21/6	-290020; -290040; -290122; -290142; -290322; -290342 Näheinrichtung, Nadelabstand 6 mm, Nadelstärke Nm 110-140, Stichtlänge max. 6 mm, für mittelschweres Nähgut. Sewing equipment, needle gauge 6 mm, needle size Nm 110-140, stitch length max. 6 mm, for medium weight material.			0867 E02106 6	0867 200220	0867 140010	0867 140040	2,2 x 3,2	0867 210220				0367 222093			0067 222343	6	0867 230134	134-35/130
E21/8	-290020; -290040; -290122; -290142; -290322; -290342 Näheinrichtung, Nadelabstand 8 mm, Nadelstärke Nm 110-140, Stichtlänge max. 6 mm, für mittelschweres Nähgut. Sewing equipment, needle gauge 8 mm, needle size Nm 110-140, stitch length max. 6 mm, for medium weight material.			0867 E02106 8	0867 200230	0867 140050	0867 140060	2,2 x 3,2	0867 210230				0367 222103			0067 222353	8	0867 230144	134-35/130
E21/10	-290020; -290040; -290122; -290142; -290322; -290342 Näheinrichtung, Nadelabstand 10 mm, Nadelstärke Nm 110-140, Stichtlänge max. 6 mm, für mittelschweres Nähgut. Sewing equipment, needle gauge 10 mm, needle size Nm 110-140, stitch length max. 6 mm, for medium weight material.			0867 E02106 10	0867 200240	0867 140050	0867 140060	2,2 x 3,2	0867 210240				0367 222013			0067 222363	10	0867 230154	134-35/130

■ = Änderung / Modification



Näheinrichtungen 867 Standard

Sewing equipment

Ausgabe
Edition
02.06

Blatt 21
Page

Fortsetzung Blatt 22
Continued page

E-Nr. E-No.	Für Unterklasse / For Subclass	Abb.-Nr. Fig.No.	Verwendungszweck / Use	Material No. / Material Nr.	Stichplatte Throat plate			Transporteur Feed dog				Presserfuß Presser foot		Transp. Fuß Feeding foot						
					① Stichplatte / Throat plate	⑦ Schieber, links / Slide, left	⑥ Schieber, rechts / Slide, right	Stichlochgröße / Stich hole size mm	Sägeverzahnung / Serrated mm	Säge-schrägverzahnung / Serrated, oblique mm	Kreuzverzahnung / Cross toothed mm	Dachverzahnung / Roof-shaped mm	Drückerfuß / Presser foot	Unverzahnung / Non toothed	Hüpfertfuß, kreuzverz. / Skipping f., cross toothed	Ausgleichfuß / Compensating foot	Kreuzverzahnung / Cross toothed mm	Unverzahnung / Non toothed	Nadelabstand / Needle distance	Nadelhalter / Needle holder
E21/12	-290020; -290040; -290122; -290142; -290322; -290342 Näheinrichtung, Nadelabstand 12 mm, Nadelstärke Nm 110-140, Stichlänge max. 6 mm, für mittelschweres Nähgut. Sewing equipment, needle gauge 12 mm, needle size Nm 110-140, stitch length max. 6 mm, for medium weight material.			0867 E02106 12	0867 200250	0867 140070	0867 140080	2,2 x 3,2	0867 210250				0367 222313				0067 222393	12	0867 230164	134-35/130
E21/14	-290020; -290040; -290122; -290142; -290322; -290342 Näheinrichtung, Nadelabstand 14 mm, Nadelstärke Nm 110-140, Stichlänge max. 6 mm, für mittelschweres Nähgut. Sewing equipment, needle gauge 14 mm, needle size Nm 110-140, stitch length max. 6 mm, for medium weight material.			0867 E02106 14	0867 200260	0867 140070	0867 140080	2,2 x 3,2	0867 210260				0367 222323				0067 222413	14	0867 230174	134-35/130
E21/16	-290020; -290040; -290122; -290142; -290322; -290342 Näheinrichtung, Nadelabstand 16 mm, Nadelstärke Nm 110-140, Stichlänge max. 6 mm, für mittelschweres Nähgut Sewing equipment, needle gauge 16 mm, needle size Nm 110-140, stitch length max. 6 mm, for medium weight material.			0867 E02106 16	0867 200270	0867 140090	0867 140100	2,2 x 3,2	0867 210270				0367 222333				0067 222423	16	0867 230184	134-35/130
E21/18	-290020; -290040; -290122; -290142; -290322; -290342 Näheinrichtung, Nadelabstand 18 mm, Nadelstärke Nm 110-140, Stichlänge max. 6 mm, für mittelschweres Nähgut. Sewing equipment, needle gauge 18 mm, needle size Nm 110-140, stitch length max. 6 mm, for medium weight material.			0867 E02106 18	0867 200280	0867 140090	0867 140100	2,2 x 3,2	0867 210280				0367 222533				0067 222433	18	0867 230194	134-35/130
E21/20	-290020; -290040; -290122; -290142; -290322; -290342 Näheinrichtung, Nadelabstand 20 mm, Nadelstärke Nm 110-140, Stichlänge max. 6 mm, für mittelschweres Nähgut. Sewing equipment, needle gauge 20 mm, needle size Nm 110-140, stitch length max. 6 mm, for medium weight material.			0867 E02106 20	0867 200290	0867 140110	0867 140120	2,2 x 3,2	0867 210290				0367 222543				0067 222443	20	0867 230204	134-35/130

■ = Änderung / Modification



Näheinrichtungen 867 Standard

Sewing equipment

Ausgabe
Edition
09.10

Blatt 22
Page

Ersetzt Ausgabe
Replaced edition
02.06

Fortsetzung Blatt 23
Continued page

E-Nr. E-No.	Für Unterklasse / For Subclass	Abb.-Nr. Fig.No.	Verwendungszweck / Use	Material No. / Material Nr.	Stichplatte Throat plate		Transporteur Feed dog				Presserfuß Presser foot	Transp. Fuß Feeding foot						
					① Stichplatte / Throat plate	⑦ Schieber, links / Slide, left	⑥ Schieber, rechts / Slide, right	Stichlochgröße / Stich hole size mm	Sägeverzahnung / Serrated mm	Säge-schrägverzahnung / Serrated, oblique mm	Kreuzverzahnung / Cross toothed mm	Dachverzahnung / Roof-shaped mm	Drückerfuß / Presser foot	Unverzahnung / Non toothed	Hüpfenfuß, kreuzverz. / Skipping f., cross toothed	Ausgleichfuß / Compensating foot	Kreuzverzahnung / Cross toothed mm	Unverzahnung / Non toothed
E21/22	-290020; -290040; -290122; -290142; -290322; -290342		Näheinrichtung, Nadelabstand 22 mm, Nadelstärke Nm 110-140, Stichtlänge max. 6 mm, für mittelschweres Nähgut. Sewing equipment, needle gauge 22 mm, needle size Nm 110-140, stitch length max. 6 mm, for medium weight material.	0867 E02106 22	0867 200300	0867 140110	0867 140120	2,2 x 3,2	0867 210300			0367 222413			0067 222773	22	0867 230214	134-35/130
E21/50	-290020; -290040; -290122; -290142; -290322; -290342		Näheinrichtung, Nadelabstand 50 mm, Nadelstärke Nm 110-140, Stichtlänge max. 6 mm, für mittelschweres Nähgut. Sewing equipment, needle gauge 50 mm, needle size Nm 110-140, stitch length max. 6 mm, for medium weight material.	0867 E02106 50	0867 200310	0867 140130	0867 140140	2,2 x 3,2	0867 210310			0867 220403			0867 220413	50	0867 230304	134-35/130
E22/6/9	-290020; -290040; -290122; -290142; -290322; -290342		Näheinrichtung zum Aussteppen von Schließnähten, Nadelabstand 6 mm, Nadelstärke Nm 110-140, Stichtlänge max. 9 mm, für mittelschweres Nähgut. Sewing equipment for topstitching of closing seams, needle gauge 6 mm, needle size Nm 110-140, stitch length max. 9 mm, for medium weight material.	0867 E02209 6	0867 200400	0867 140010	0867 140040	2,2 x 3,2	0867 210220			0768 222123			0768 222264	6	0867 230134	134-35/130
E22/8/6	-290020; -290040; -290122; -290142; -290322; -290342		Näheinrichtung zum Aussteppen von Schließnähten, Nadelabstand 8 mm, Nadelstärke Nm 110-140, Stichtlänge max. 6 mm, für mittelschweres Nähgut. Sewing equipment for topstitching of closing seams, needle gauge 8 mm, needle size Nm 110-140, stitch length max. 6 mm, for medium weight material.	0867 E02206 8	0867 200230	0867 140050	0867 140060	2,2 x 3,2	0867 210230			0768 222133			0768 222274	8	0867 230144	134-35/130
E22/8/9	-290020; -290040; -290122; -290142; -290322; -290342		Näheinrichtung zum Aussteppen von Schließnähten, Nadelabstand 8 mm, Nadelstärke Nm 110-140, Stichtlänge max. 9 mm, für mittelschweres Nähgut. Sewing equipment for topstitching of closing seams, needle gauge 8 mm, needle size Nm 110-140, stitch length max. 9 mm, for medium weight material.	0867 E02209 8	0867 200410	0867 140050	0867 140060	2,2 x 3,2	0867 210230			0768 222133			0768 222274	8	0867 230144	134-35/130

■ = Änderung / Modification



Näheinrichtungen 867 Standard

Sewing equipment

Ausgabe
Edition
05.06

Blatt 23
Page

Ersetzt Ausgabe
Replaced edition
02.06

Fortsetzung Blatt 24
Continued page

E-Nr. E-No.	Für Unterklasse / For Subclass	Abb.-Nr. Fig.No.	Verwendungszweck / Use	Material No. / Material Nr.	Stichplatte Throat plate			Transporteur Feed dog			Presserfuß Presser foot	Transp. Fuß Feeding foot									
					①	⑦	⑥				②	④	③								
E22/10/6	-290020; -290040; -290122; -290142; -290322; -290342 Näheinrichtung zum Aussteppen von Schließnähten, Nadelabstand 10 mm, Nadelstärke Nm 110-140, Stichlänge max. 6 mm, für mittelschweres Nähgut. Sewing equipment for topstitching of closing seams, needle gauge 10 mm, needle size Nm 110-140, stitch length max. 6 mm, for medium weight material.			0867 E02206 10	0867 200240	0867 140050	0867 140060	2,2 x 3,2	0867 210240				0768 222143			0768 222284			10	0867 230154	134-35/130
E22/10/9	-290020; -290040; -290122; -290142; -290322; -290342 Näheinrichtung zum Aussteppen von Schließnähten, Nadelabstand 10 mm, Nadelstärke Nm 140-180, Stichlänge max. 9 mm, für mittelschweres Nähgut. Sewing equipment for topstitching of closing seams, needle gauge 10 mm, needle size Nm 140-180, stitch length max. 9 mm, for medium weight material.			0867 E02209 10	0867 200420	0867 140050	0867 140060	2,8 x 3,7	0867 210450				0768 222143			0768 222404			10	0867 230154	134-35/160
E22/10/12	-290020; -290040; -290122; -290142; -290322; -290342 Näheinrichtung zum Aussteppen von Schließnähten, Nadelabstand 10 mm, Nadelstärke Nm 140-180, Stichlänge max. 12 mm, für mittelschweres Nähgut. Sewing equipment for topstitching of closing seams, needle gauge 10 mm, needle size Nm 140-180, stitch length max. 12 mm, for medium weight material.			0867 E02212 10	0867 200450	0867 140050	0867 140060	2,8 x 3,7	0867 210450				0768 222143			0768 222404			10	0867 230154	134-35/160
E22/12/9	-290020; -290040; -290122; -290142; -290322; -290342 Näheinrichtung zum Aussteppen von Schließnähten, Nadelabstand 12 mm, Nadelstärke Nm 140-180, Stichlänge max. 9 mm, für mittelschweres Nähgut. Sewing equipment for topstitching of closing seams, needle gauge 12 mm, needle size Nm 140-180, stitch length max. 9 mm, for medium weight material.			0867 E02209 12	0867 200430	0867 140070	0867 140080	2,8 x 3,7	0867 210460				0768 222153			0768 222434			12	0867 230164	134-35/160

■ = Änderung / Modification



Näheinrichtungen 867 Standard

Sewing equipment

Ausgabe
Edition
01.07

Blatt 24
Page

Ersetzt Ausgabe
Replaced edition
08.06

Fortsetzung Blatt 25
Continued page

E-Nr. E-No.	Für Unterklasse / For Subclass	Abb.-Nr. Fig.No.	Verwendungszweck / Use	Material No. / Material Nr.	Stichplatte Throat plate			Transporteur Feed dog				Presserfuß Presser foot		Transp. Fuß Feeding foot			
					①	⑦	⑥	mm	mm	mm	mm	mm	mm	mm	mm	mm	mm
E22/12/12	-290020; -290040; -290122; -290142; -290322; -290342 Näheinrichtung zum Aussteppen von Schließnähten, Nadelabstand 12 mm, Nadelstärke Nm 140-180, Stichtlänge max. 12 mm, für mittelschweres Nähgut. Sewing equipment for topstitching of closing seams, needle gauge 12 mm, needle size Nm 140-180, stitch length max. 12 mm, for medium weight material.			0867 E02212 12	0867 200460	0867 140070	0867 140080	2,8 x 3,7	0867 210460			0768 222153		0768 222434	12	0867 230164	134-35/160
E22/14/12	-290020; -290040; -290122; -290142; -290322; -290342 Näheinrichtung zum Aussteppen von Schließnähten, Nadelabstand 14 mm, Nadelstärke Nm 140-180, Stichtlänge max. 12 mm, für mittelschweres Nähgut. Sewing equipment for topstitching of closing seams, needle gauge 14 mm, needle size Nm 140-180, stitch length max. 12 mm, for medium weight material.			0867 E02212 14	0867 200470	0867 140070	0867 140080	2,8 x 3,7	0867 210470			0867 222163		0768 222464	14	0867 230174	134-35/160
E23/10	-290020; -290040; -290122; -290142; -290322; -290342 Näheinrichtung zum Einnähen von Reißverschlüssen, Nadelabstand 10 mm, Nadelstärke Nm 110-140, Stichtlänge max. 6 mm, für mittelschweres Nähgut. Sewing equipment for inserting zippers, needle gauge 10 mm, needle size Nm 110-140, stitch length max. 6 mm, for medium weight material.			0867 E02306 10	0867 200950	0867 140050	0867 140060	∅ 1,7	0867 210950			0367 222510		0067 224103	10	0867 230154	134-35/130
E23/12	-290020; -290040; -290122; -290142; -290322; -290342 Näheinrichtung zum Einnähen von Reißverschlüssen, Nadelabstand 12 mm, Nadelstärke Nm 110-140, Stichtlänge max. 6 mm, für mittelschweres Nähgut. Sewing equipment for inserting zippers, needle gauge 12 mm, needle size Nm 110-140, stitch length max. 6 mm, for medium weight material.			0867 E02306 12	0867 200960	0867 140070	0867 140080	∅ 2	0867 210960			0367 222373		0067 223223	12	0867 230164	134-35/130

■ = Änderung / Modification



Näheinrichtungen 867 Standard

Sewing equipment

Ausgabe
Edition
01.07

Blatt 25
Page

Ersetzt Ausgabe
Replaced edition
02.06

Fortsetzung Blatt 26
Continued page

E-Nr. E-No.	Für Unterklasse / For Subclass	Abb.-Nr. Fig.No.	Verwendungszweck / Use	Material No. / Material Nr.	Stichplatte	Transporteur				Presserfuß	Transp. Fuß					
					Throat plate	Feed dog	②	④	③							
					①	⑦	⑥									
E24/6/9	-290122; -290142; -290322; -290342 Näheinrichtung zum Aussteppen von Schließnähten, Nadelabstand 6 mm, Nadelstärke Nm 110-140, Stichtlänge max. 9 mm, für mittelschweres Nähgut. Sewing equipment for topstitching of closing seams, needle gauge 6 mm, needle size Nm 110-140, stitch length max. 9 mm, for medium weight material.			0867 E02409 6	0867 200400	0867 140010	0867 140040	2,2 x 3,2	0867 210220		0768 222664		0768 222264	6	0867 230134	134-35/130
E24/8/9	-290122; -290142; -290322; -290342 Näheinrichtung zum Aussteppen von Schließnähten, Nadelabstand 8 mm, Nadelstärke Nm 110-140, Stichtlänge max. 9 mm, für mittelschweres Nähgut. Sewing equipment for topstitching of closing seams, needle gauge 8 mm, needle size Nm 110-140, stitch length max. 9 mm, for medium weight material.			0867 E02409 8	0867 200410	0867 140050	0867 140060	2,2 x 3,2	0867 210230		0768 222674		0768 222274	8	0867 230144	134-35/130
E24/10/9	-290122; -290142; -290322; -290342 Näheinrichtung zum Aussteppen von Schließnähten, Nadelabstand 10 mm, Nadelstärke Nm 110-140, Stichtlänge max. 9 mm, für mittelschweres Nähgut. Sewing equipment for topstitching of closing seams, needle gauge 10 mm, needle size Nm 110-140, stitch length max. 9 mm, for medium weight material.			0867 E02409 10	0867 200420	0867 140050	0867 140060	2,2 x 3,2	0867 210240		0768 222684		0768 222284	10	0867 230154	134-35/130
E24/12/9	-290122; -290142; -290322; -290342 Näheinrichtung zum Aussteppen von Schließnähten, Nadelabstand 12 mm, Nadelstärke Nm 110-140, Stichtlänge max. 9 mm, für mittelschweres Nähgut. Sewing equipment for topstitching of closing seams, needle gauge 12 mm, needle size Nm 110-140, stitch length max. 9 mm, for medium weight material.			0867 E02409 12	0867 200430	0867 140070	0867 140080	2,2 x 3,2	0867 210250		0768 222694		0768 222294	12	0867 230164	134-35/130

■ = Änderung / Modification



Näheinrichtungen 867 Standard

Sewing equipment

Ausgabe
Edition
08.06

Blatt 26
Page

Ersetzt Ausgabe
Replaced edition
05.06

Fortsetzung Blatt 27
Continued page

E-Nr. E-No.	Für Unterklasse / For Subclass	Abb.-Nr. Fig.No.	Verwendungszweck / Use	Material No. / Material Nr.	Stichplatte Throat plate			Stichlochgröße / Stich hole size mm	Transporteur Feed dog				Drückerfuß / Presser foot	Unverzahnt / Non toothed	Hüpfertfuß, kreuzverz. / Skipping f., cross toothed	Ausgleichfuß / Compensating foot	Kreuzverzahnt / Cross toothed mm	Unverzahnt / Non toothed	Nadelabstand / Needle distance	Nadelhalter / Needle holder	Nadelsystem / -dicke / Needle system / -size
					①	⑦	⑥		②	③	④	⑤									
E24/8/12	-290122; -290142; -290322; -290342 Näheinrichtung zum Aussteppen von Schließnähten, Nadelabstand 8 mm, Nadelstärke Nm 140-180, Stichtlänge max. 12 mm, für mittelschweres Nähgut. Sewing equipment for topstitching of closing seams, needle gauge 8 mm, needle size Nm 140-180, stitch length max. 12 mm, for medium weight material.			0867 E02412 8	0867 200440	0867 140050	0867 140060	2,8 x 3,7	0867 210440			0867 220054			0768 222374			8	0867 230144	134-35/160	
E24/10/12	-290122; -290142; -290322; -290342 Näheinrichtung zum Aussteppen von Schließnähten, Nadelabstand 10 mm, Nadelstärke Nm 140-180, Stichtlänge max. 12 mm, für mittelschweres Nähgut. Sewing equipment for topstitching of closing seams, needle gauge 10 mm, needle size Nm 140-180, stitch length max. 12 mm, for medium weight material.			0867 E02412 10	0867 200450	0867 140050	0867 140060	2,8 x 3,7	0867 210450			0867 220064			0768 222404			10	0867 230154	134-35/160	
E24/12/12	-290122; -290142; -290322; -290342 Näheinrichtung zum Aussteppen von Schließnähten, Nadelabstand 12 mm, Nadelstärke Nm 140-180, Stichtlänge max. 12 mm, für mittelschweres Nähgut. Sewing equipment for topstitching of closing seams, needle gauge 12 mm, needle size Nm 140-180, stitch length max. 12 mm, for medium weight material.			0867 E02412 12	0867 200460	0867 140070	0867 140080	2,8 x 3,7	0867 210460			0867 220074			0768 222434			12	0867 230164	134-35/160	
E24/14/12	-290122; -290142; -290322; -290342 Näheinrichtung zum Aussteppen von Schließnähten, Nadelabstand 14 mm, Nadelstärke Nm 140-180, Stichtlänge max. 12 mm, für mittelschweres Nähgut. Sewing equipment for topstitching of closing seams, needle gauge 14 mm, needle size Nm 140-180, stitch length max. 12 mm, for medium weight material.			0867 E02412 14	0867 200470	0867 140070	0867 140080	2,8 x 3,7	0867 210470			0867 220084			0768 222464			14	0867 230174	134-35/160	

■ = Änderung / Modification



Näheinrichtungen 867 Standard

Sewing equipment

Ausgabe
Edition
01.07

Blatt 27
Page

Ersetzt Ausgabe
Replaced edition
08.06

Fortsetzung Blatt 28
Continued page

E-Nr. E-No.	Für Unterklasse / For Subclass	Abb.-Nr. Fig.No.	Verwendungszweck / Use	Material No. / Material Nr.	Stichplatte Throat plate		Transporteur Feed dog	Presserfuß Presser foot	Transp. Fuß Feeding foot									
					①	⑦				⑥	②	④	③					
E51/8/9	-290020; -290040; -290122; -290142; -290322; -290342		Näheinrichtung asymmetrisch für allgemeine Näharbeiten. Die rechte Nadel befindet sich auf der Mitte der Nadelstange, um die Maschine auch als Einnadelmaschine einsetzen zu können. Nadelabstand 8 mm, Nadelstärke Nm 110-140, Stichlänge max. 9 mm, für mittelschweres Nähgut. Sewing equipment asymmetric for general sewing operations. The right needle is located on the needle bar center so that the machine could be also used as a single needle one. Needle gauge 8 mm, needle size Nm 110-140, stitch length max. 9 mm, for medium weight material.	0867 E05109 8	0867 200500	0867 140090	0867 140020	2,2 x 3,2	0867 210500			0867 220033			0867 220043	8	0867 230014	134-35/130
E51/10/9	-290020; -290040; -290122; -290142; -290322; -290342		Näheinrichtung asymmetrisch für allgemeine Näharbeiten. Die rechte Nadel befindet sich auf der Mitte der Nadelstange, um die Maschine auch als Einnadelmaschine einsetzen zu können. Nadelabstand 10 mm, Nadelstärke Nm 110-140, Stichlänge max. 9 mm, für mittelschweres Nähgut. Sewing equipment asymmetric for general sewing operations. The right needle is located on the needle bar center so that the machine could be also used as a single needle one. Needle gauge 10 mm, needle size Nm 110-140, stitch length max. 9 mm, for medium weight material.	0867 E05109 10	0867 200510	0867 140110	0867 140020	2,2 x 3,2	0867 210510			0467 222123			0467 222113	10	0867 230024	134-35/130
E51/12/9	-290020; -290040; -290122; -290142; -290322; -290342		Näheinrichtung asymmetrisch für allgemeine Näharbeiten. Die rechte Nadel befindet sich auf der Mitte der Nadelstange, um die Maschine auch als Einnadelmaschine einsetzen zu können. Nadelabstand 12 mm, Nadelstärke Nm 110-140, Stichlänge max. 9 mm, für mittelschweres Nähgut. Sewing equipment asymmetric for general sewing operations. The right needle is located on the needle bar center so that the machine could be also used as a single needle one. Needle gauge 12 mm, needle size Nm 110-140, stitch length max. 9 mm, for medium weight material.	0867 E05109 12	0867 200520	0867 140170	0867 140020	2,2 x 3,2	0867 210520			0467 222183			0467 222173	12	0867 230034	134-35/130

■ = Änderung / Modification



Näheinrichtungen 867 Standard

Sewing equipment

Ausgabe
Edition
05.11

Blatt 28
Page

Ersetzt Ausgabe
Replaced edition
10.07

Fortsetzung Blatt 29
Continued page

E-Nr. E-No.	Für Unterklasse / For Subclass	Abb.-Nr. Fig.No.	Verwendungszweck / Use	Material No. / Material Nr.	Stichplatte Throat plate		Transporteur Feed dog				Presserfuß Presser foot		Transp. Fuß Feeding foot				
					① Stichplatte / Throat plate	⑦ Schieber, links / Slide, left	⑥ Schieber, rechts / Slide, right	Stichlochgröße / Stich hole size mm	Sägezahn / Serrated mm	Säge-schrägverzahn / Serrated, oblique mm	Kreuzzahn / Cross toothed mm	Dachverzahn / Roof-shaped mm	Drückerfuß / Presser foot	Unverzahn / Non toothed	Hüpfersfuß, kreuzverz. / Skipping f., cross toothed	Ausgleichfuß / Compensating foot	Kreuzzahn / Cross toothed mm
E51/14/9	-290020; -290040; -290122; -290142; -290322; -290342		Näheinrichtung asymmetrisch für allgemeine Näharbeiten. Die rechte Nadel befindet sich auf der Mitte der Nadelstange, um die Maschine auch als Einnadelmaschine einsetzen zu können. Nadelabstand 14 mm, Nadelstärke Nm 110-140, Stichlänge max. 9 mm, für mittelschweres Nähgut. Sewing equipment asymmetric for general sewing operations. The right needle is located on the needle bar center so that the machine could be also used as a single needle one. Needle gauge 14 mm, needle size Nm 110-140, stitch length max. 9 mm, for medium weight material.	0867 E05109 14	0867 200530	0867 140190	0867 140020	2,2 x 3,2	0867 210530			0467 222143		0467 222133	14	0867 230044	134-35/130
E75/3,2/6	-260122		Näheinrichtung, Nadelabstand 3,2 mm, Nadelstärke Nm 80-120, Stichlänge max. 6 mm, für leichtes und mittelschweres Nähgut. Sewing equipment, needle gauge 3,2 mm, needle size Nm 80-120, stitch length max. 6 mm, for light and medium weight material.	0867 E07506 32	0867 201250	0867 140743	0867 140783	∅ 2	0867 211250			0867 220664		0867 220624	3,2	0867 230424	134-35/110
E75/4,8/6	-260122		Näheinrichtung, Nadelabstand 4,8 mm, Nadelstärke Nm 80-120, Stichlänge max. 6 mm, für leichtes und mittelschweres Nähgut. Sewing equipment, needle gauge 4,8 mm, needle size Nm 80-120, stitch length max. 6 mm, for light and medium weight material.	0867 E07506 48	0867 201260	0867 140743	0867 140783	∅ 2	0867 211260			0867 220674		0867 220634	4,8	0867 230414	134-35/110
E75/6,4/6	-260122		Näheinrichtung, Nadelabstand 6,4 mm, needle size Nm 80-120, stitch length max. 6 mm, for light and medium weight material. Sewing equipment, needle gauge 6,4 mm, needle size Nm 80-120, stitch length max. 6 mm, for light and medium weight material.	0867 E07506 64	0867 201270	0867 140743	0867 140783	∅ 2	0867 211270			0867 220694		0867 220684	6,4	0867 230154	134-35/110

■ = Änderung / Modification



Näheinrichtungen 867 Standard

Sewing equipment

Ausgabe
Edition
10.07

Blatt 29
Page

Fortsetzung Blatt 30
Continued page

E-Nr. E-No.	Für Unterklasse / For Subclass	Abb.-Nr. Fig.No.	Verwendungszweck / Use	Material No. / Material Nr.	Stichplatte Throat plate			Transporteur Feed dog				Presserfuß Presser foot		Transp. Fuß Feeding foot		⑤	Nadelhalter / Needle holder	Nadelsystem / -dicke / Needle system / -size	
					①	⑦	⑥	mm	mm	mm	mm	mm	mm	mm	mm				mm
E121/6/6	-290445 Näheinrichtung, Nadelabstand 6 mm, Nadelstärke Nm 110-140, Stichtlänge max. 6 mm, für mittelschweres Nähgut; mit Kurzfadenabschneider. Sewing equipment, needle gauge 6 mm, needle size Nm 110-140, stitch length max. 6 mm, for medium weight material; with short thread trimmer			0867 E12106 6	0867 200620	0867 140153	0867 140303	2,2 x 3,2	0867 210620			0367 222093				0067 222343	6	0867 230134	134-35/130
E121/8/6	-290445 Näheinrichtung, Nadelabstand 8 mm, Nadelstärke Nm 110-140, Stichtlänge max. 6 mm, für mittelschweres Nähgut; mit Kurzfadenabschneider. Sewing equipment, needle gauge 8 mm, needle size Nm 110-140, stitch length max. 6 mm, for medium weight material; with short thread trimmer			0867 E12106 8	0867 200630	0867 140313	0867 140323	2,2 x 3,2	0867 210630			0367 222103				0067 222353	8	0867 230144	134-35/130
E121/10/6	-290445 Näheinrichtung, Nadelabstand 10 mm, Nadelstärke Nm 110-140, Stichtlänge max. 6 mm, für mittelschweres Nähgut; mit Kurzfadenabschneider. Sewing equipment, needle gauge 10 mm, needle size Nm 110-140, stitch length max. 6 mm, for medium weight material; with short thread trimmer			0867 E12106 10	0867 200640	0867 140313	0867 140323	2,2 x 3,2	0867 210640			0367 222013				0067 222383	10	0867 230154	134-35/130
E121/12/6	-290445 Näheinrichtung, Nadelabstand 12 mm, Nadelstärke Nm 110-140, Stichtlänge max. 6 mm, für mittelschweres Nähgut; mit Kurzfadenabschneider. Sewing equipment, needle gauge 12 mm, needle size Nm 110-140, stitch length max. 6 mm, for medium weight material; with short thread trimmer			0867 E12106 12	0867 200650	0867 140333	0867 140343	2,2 x 3,2	0867 210650			0367 222313				0067 222393	12	0867 230164	134-35/130

■ = Änderung / Modification



Näheinrichtungen 867 Standard

Sewing equipment

Ausgabe
Edition
10.07

Blatt 30
Page

Fortsetzung Blatt _
Continued page

E-Nr. E-No.	Für Unterklasse / For Subclass	Abb.-Nr. Fig.No.	Verwendungszweck / Use	Material No. / Material Nr.	Stichplatte Throat plate			Transporteur Feed dog				Presserfuß Presser foot	Transp. Fuß Feeding foot								
					①	⑦	⑥					②	④	③	⑤						
E122/6/9	-290445 Näheinrichtung zum Aussteppen von Schließnähten, Nadelabstand 6 mm, Nadelstärke Nm 110-140, Stichtlänge max. 9 mm, für mittelschweres Nähgut; mit Kurzfadenabschneider. Sewing equipment for topstitching of closing seams, needle gauge 6 mm, needle size Nm 110-140, stitch length max. 9 mm, for medium weight material; with short thread trimmer			0867 E12209 6	0867 200800	0867 140153	0867 140303	2,2 x 3,2	0867 210620				0768 222123			0768 222264			6	0867 230134	134-35/130
E122/8/9	-290445 Näheinrichtung zum Aussteppen von Schließnähten, Nadelabstand 8 mm, Nadelstärke Nm 110-140, Stichtlänge max. 9 mm, für mittelschweres Nähgut; mit Kurzfadenabschneider. Sewing equipment for topstitching of closing seams, needle gauge 8 mm, needle size Nm 110-140, stitch length max. 9 mm, for medium weight material; with short thread trimmer			0867 E12209 8	0867 200810	0867 140313	0867 140323	2,2 x 3,2	0867 210630				0768 222133			0768 222274			8	0867 230144	134-35/130
E122/10/9	-290445 Näheinrichtung zum Aussteppen von Schließnähten, Nadelabstand 10 mm, Nadelstärke Nm 140-180, Stichtlänge max. 9 mm, für mittelschweres Nähgut; mit Kurzfadenabschneider. Sewing equipment for topstitching of closing seams, needle gauge 10 mm, needle size Nm 140-180, stitch length max. 9 mm, for medium weight material; with short thread trimmer			0867 E12209 10	0867 200820	0867 140313	0867 140323	2,2 x 3,2	0867 210640				0768 222143			0768 222404			10	0367 230154	134-35/160
E122/12/9	-290445 Näheinrichtung zum Aussteppen von Schließnähten, Nadelabstand 12 mm, Nadelstärke Nm 140-180, Stichtlänge max. 9 mm, für mittelschweres Nähgut; mit Kurzfadenabschneider. Sewing equipment for topstitching of closing seams, needle gauge 12 mm, needle size Nm 140-180, stitch length max. 9 mm, for medium weight material; with short thread trimmer			0867 E12209 12	0867 200830	0867 140333	0867 140343	2,2 x 3,2	0867 210650				0768 222153			0768222434			12	0867 230164	134-35/160

█ = Änderung / Modification

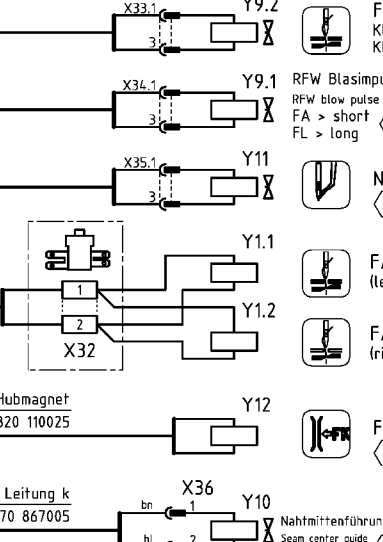
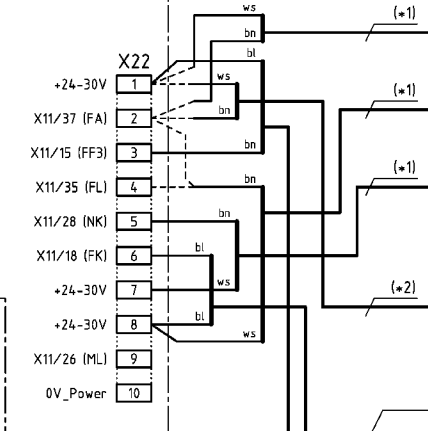
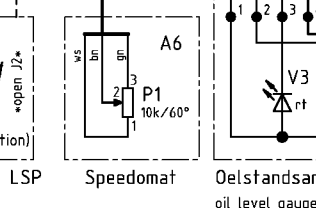
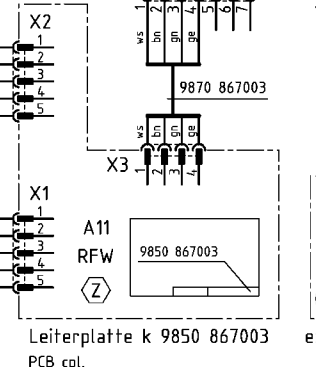
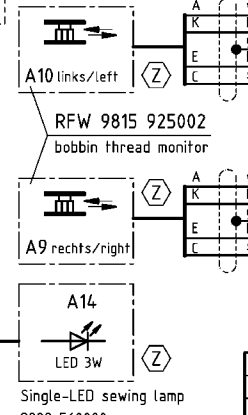
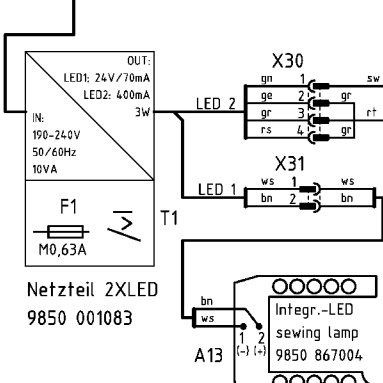
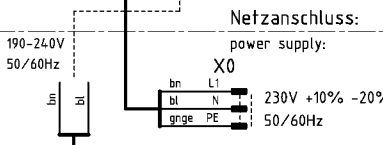
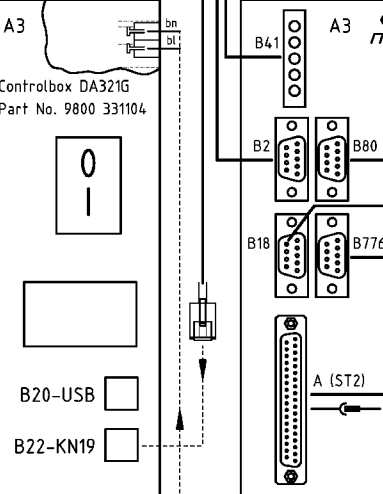
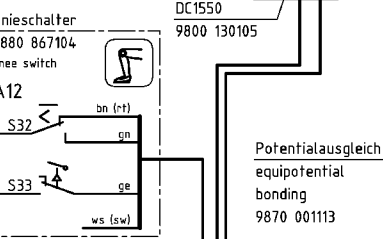
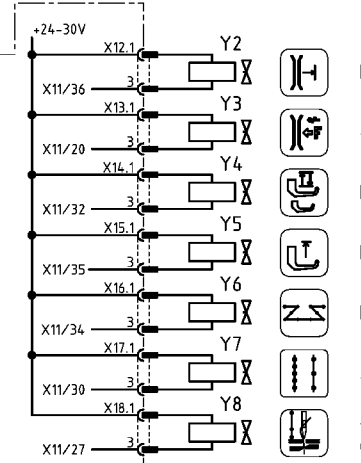
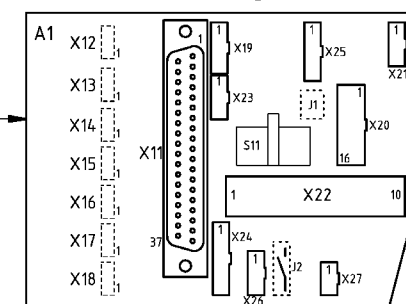
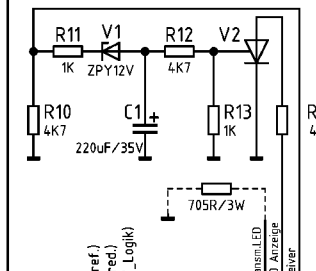
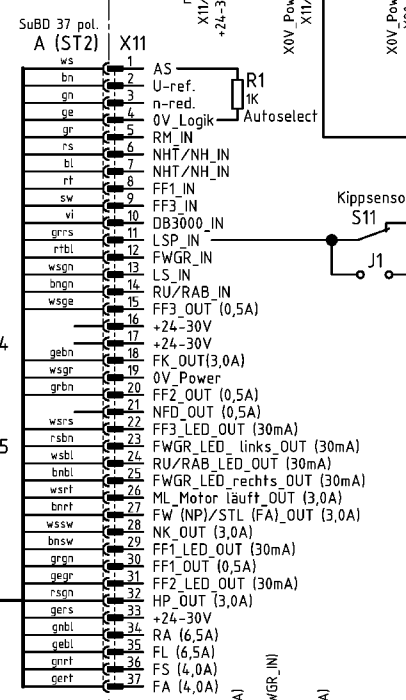
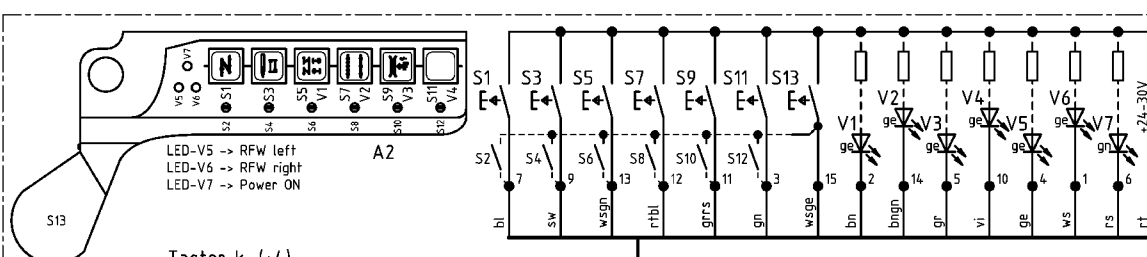
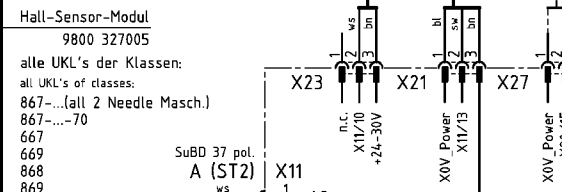
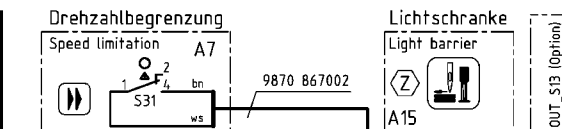
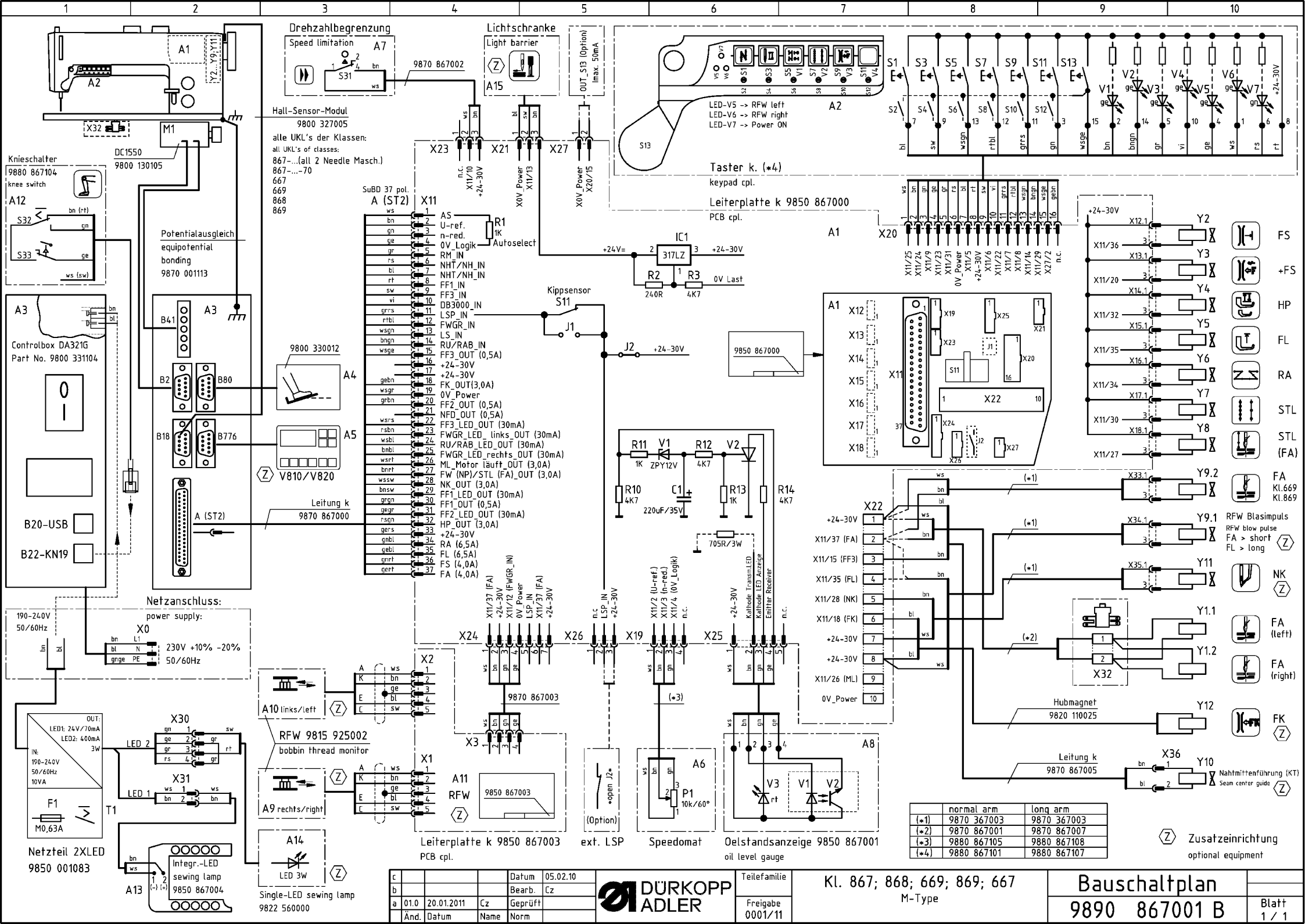

	normal arm	long arm
(*1)	9870 367003	9870 367003
(*2)	9870 867001	9870 867007
(*3)	9880 867105	9880 867108
(*4)	9880 867101	9880 867107

(Z) Zusatzeinrichtung
optional equipment

c		Datum	05.02.10
b		Bearb.	Cz
a	01.0	20.01.2011	Cz
Änd.	Datum	Name	Norm



Teilefamilie
Freigabe
0001/11

Kl. 867; 868; 669; 869; 667
M-Type

Bauschaltplan
9890 867001 B

Blatt
1 / 1

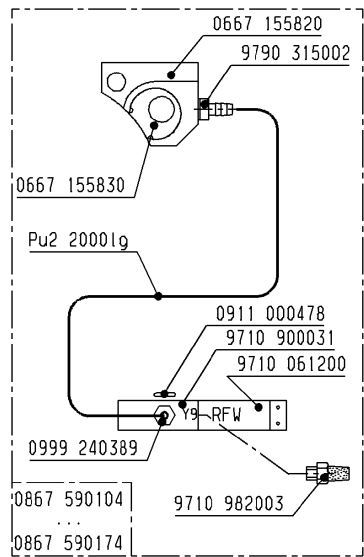
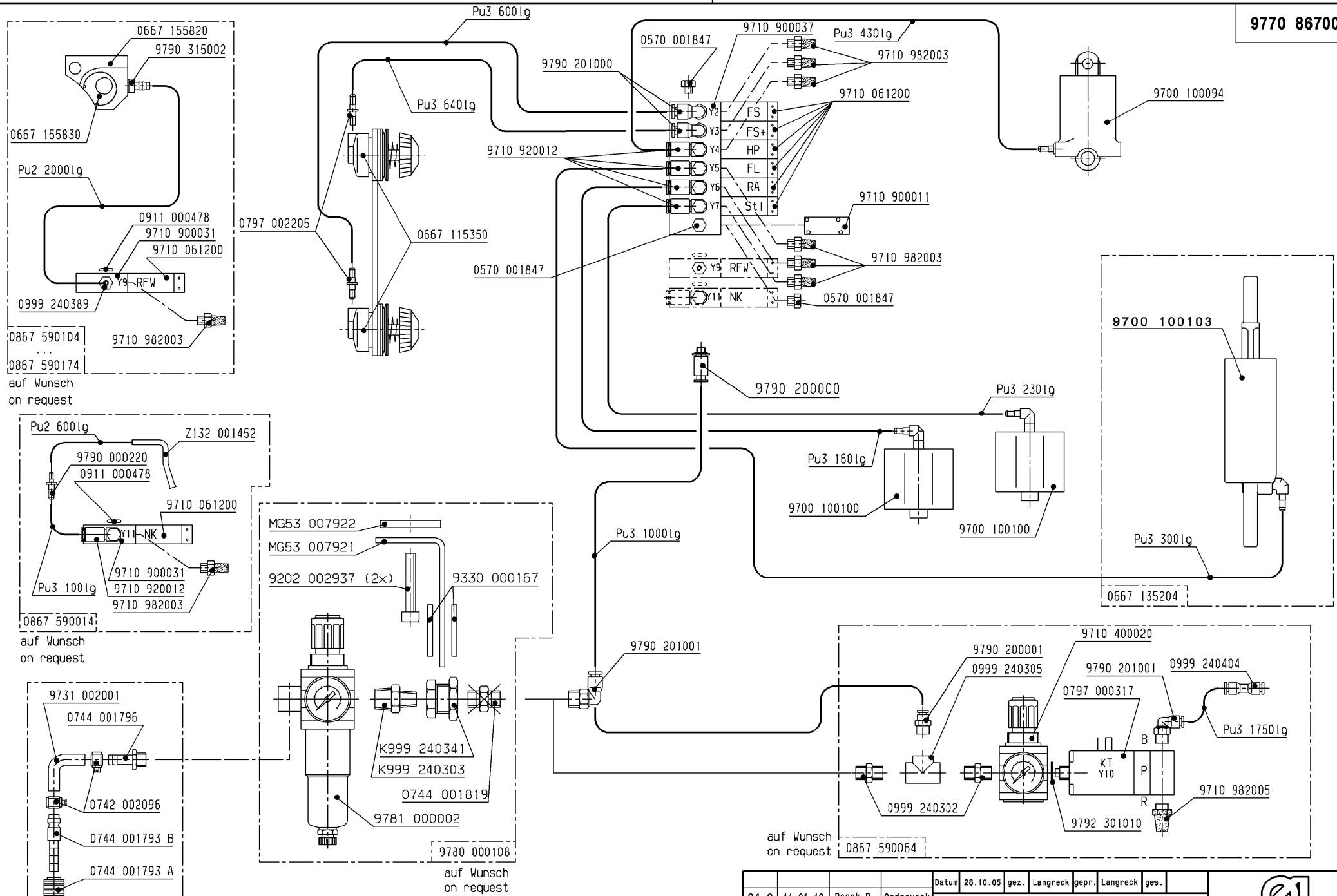

auf Wunsch
on request

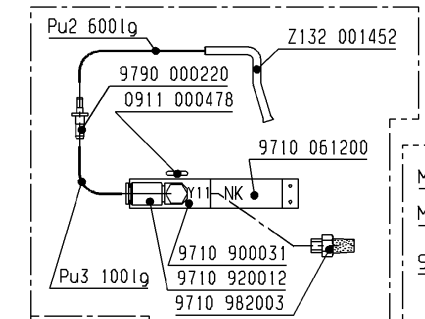

auf Wunsch
on request

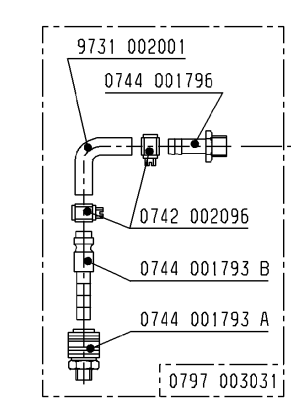

auf Wunsch
on request

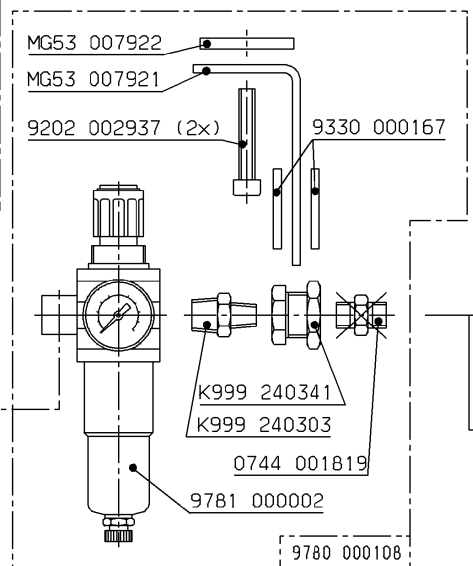

auf Wunsch
on request

04.0	11.01.10	Pasek P.	Ondrousek
03.0	27.10.09	Schubert	Schubert
02.0	30.01.08	Schmid	Schubert
01.0	31.10.07	Schmid	Langreck
Änd.	Datum	gez.	gepr.

Datum	28.10.05	gez.	Langreck	gepr.	Langreck	gez.
Pneu.-Geräteplan für Pneu.-Elements-Plan for 0867-1903..						

DÜRKOPP ADLER AG
9770 867001
Blatt 1 Blattz. 7

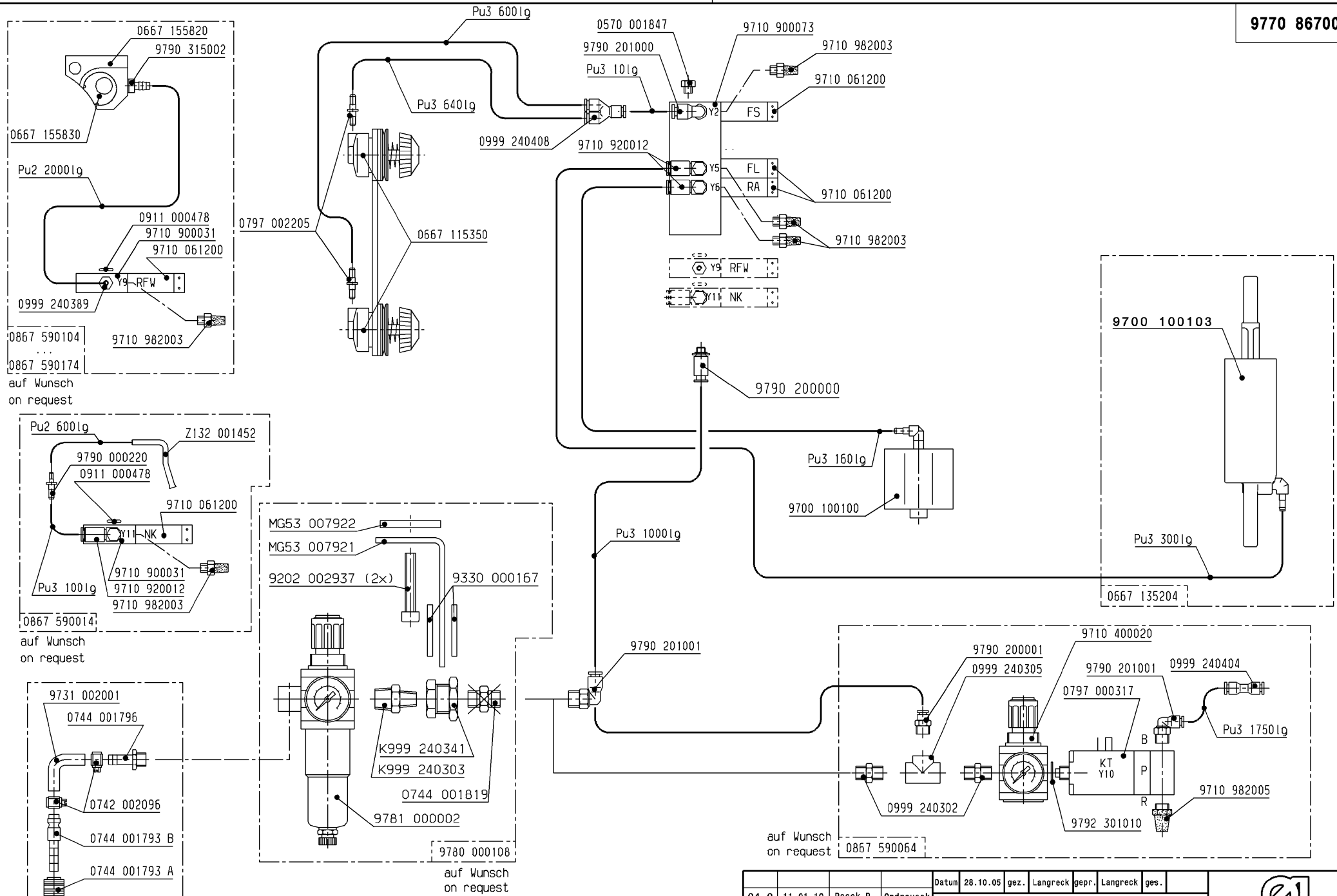

auf Wunsch
on request

auf Wunsch
on request

auf Wunsch
on request

auf Wunsch
on request

auf Wunsch
on request

Schlauch	Teile-Nr. (Meterware)
Hose	Part-No. (Yarded goods)
PU2	0699 979265
PU3	9731 005004

04.0	11.01.10	Pasek P.	Ondrousek
03.0	27.10.09	Schubert	Schubert
02.0	30.01.08	Schmid	Schubert
01.0	31.10.07	Schmid	Langreck
Änd.	Datum	gez.	gepr.

Datum 28.10.05 gez. Langreck gepr. Langreck ges.
Pneu.-Geräteplan für
Pneu.-Elements-Plan for
0867-190122
0867-190142

DÜRKOPP ADLER AG
9770 867001
 Blatt 3 Blattz. 7

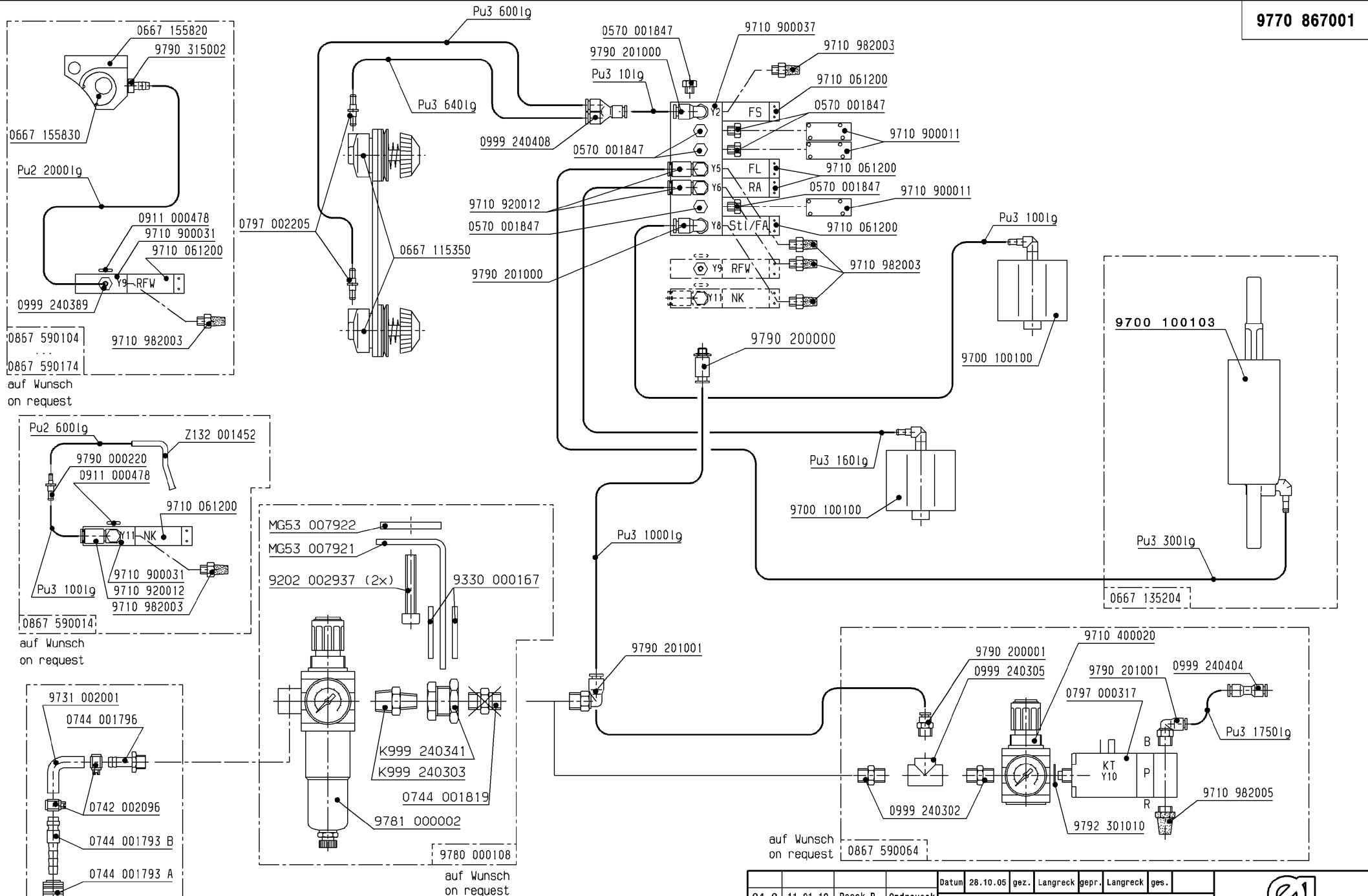

Schutzvermerk
DIN
A3
150 16016 beachten

Schlauch Hose	Teile-Nr. (Meterware) Part-No. (Yarded goods)
PU2	0699 979265
PU3	9731 005004

04.0	11.01.10	Pasek P.	Ondrousek
03.0	27.10.09	Schubert	Schubert
02.0	30.01.08	Schmid	Schubert
01.0	31.10.07	Schmid	Langreck
Änd.	Datum	gez.	gepr.

Datum	28.10.05	gez.	Langreck	gepr.	Langreck	gez.
Pneu.-Geräteplan für Pneu.-Elements-Plan for 0867-190145						



DÜRKOPP ADLER AG

9770 867001

Blatt 4 | Blattz. 7